



BEST MANAGEMENT PRACTICES



for

ROADS, FACILITIES, PARKS & NATURAL AREAS

Updated 2022

1	BENTON COUNTY BEST MANAGEMENT PRACTICES (2022)
2	APPENDIX A: EROSION & SEDIMENT CONTROL DETAILS (ODOT 2022)
3	APPENDIX B: PESTICIDE-TREATED WOOD (ODOT 2022)
4	APPENDIX C: BEAVER DAM MODIFICATION FLOW CHART (ODOT 2020)
5	APPENDIX D: NMFS FISH SCREEN CRITERIA (ODOT 2020)
6	APPENDIX E: VEGETATION MANAGEMENT GUIDELINES (BENTON CO. 2010)
7	APPENDIX F: TIMING OF IN-WATER WORK (BENTON CO. 2022)
8	APPENDIX G: ODOT EROSION CONTROL MANUAL (ODOT 2019)
9	APPENDIX H: TEMPORARY WATER MANAGEMENT (ODOT 2014)
10	APPENDIX I: WHEN IS A PERMIT REQUIRED? (ODSL 2019)

Benton County
**ROADS, FACILITIES, PARKS & NATURAL
AREAS**



**STANDARD OPERATING PROCEDURES &
BEST MANAGEMENT PRACTICES**

2022

CONTENTS

INTRODUCTION	1
CULTURAL AND NATURAL RESOURCES	2
Archaeological Resources	2
Nesting Birds and Bat Colonies	2
Water Quality	2
GENERAL GOOD HOUSEKEEPING	3
Safety	3
Streams and Waterways – Best Management Practices	3
Vegetation – Best Management Practices	3
BEST MANAGEMENT PRACTICES	4
1 ATTENUATOR MAINTENANCE	4
1.1.1 Description	4
1.1.2 Mitigation, Avoidance and BMPs:.....	4
2 BRIDGE CLEANING AND MAINTENANCE	4
2.1.1 Description	4
2.2 Drift Removal	4
2.3 Bridge Cleaning	5
2.3.1 Pressure Washing.....	5
2.3.2 Sweeping.....	5
2.3.3 Bird Nests	5
2.3.4 Fish	5
3 BRIDGE REPAIR	6
3.1.1 Description	6
3.1.2 Mitigation, Avoidance and BMPs.....	6
3.2 In-Water Work	6
3.3 Wildlife	6
3.4 Water Quality	7
3.5 Piling.....	7
4 STREAM CHANNEL MAINTENANCE	7
4.1.1 Description	7
4.1.2 Mitigation, Avoidance and BMPs.....	7
5 CULVERT AND INLET CLEANING AND REPAIR	8
5.1.1 Description	8
5.2 Culvert Cleaning and Debris Dam Removal.....	9

5.2.1	<i>Trash Rack Maintenance/Cleaning</i>	9
5.2.2	<i>Beaver Dams</i>	10
5.2.3	<i>Culvert/Inlet Repair</i>	12
6	STORMWATER MANAGEMENT	12
6.1.1	<i>Description</i>	12
6.1.2	<i>Mitigation, Avoidance and BMPs</i>	12
6.2	<i>Construction</i>	12
6.3	<i>Catch Basin Cleaning</i>	12
6.4	<i>Curb and Gutter Cleaning</i>	13
7	DITCH SHAPING AND CLEANING	13
7.1.1	<i>Description</i>	13
7.1.2	<i>Mitigation, Avoidance and BMPs</i>	13
7.2	<i>Skip Ditching</i>	14
8	DUST ABATEMENT	14
8.1.1	<i>Description</i>	14
8.1.2	<i>Mitigation, Avoidance and BMPs</i>	15
9	EMERGENCY ROAD MAINTENANCE	15
9.1.1	<i>Description:</i>	15
9.1.2	<i>Mitigation, Avoidance and BMPs:</i>	16
9.2	<i>Extraordinary Maintenance</i>	16
9.3	<i>Riprap – Emergency Installation</i>	17
9.4	<i>Emergency Pile Installation</i>	17
9.5	<i>Fish Passage, Screening, Capture and Removal in Emergency Circumstances</i>	17
9.6	<i>Emergency Establishment of Temporary Access Roads</i>	17
9.7	<i>Erosion Control and Site Management in Emergency Situations</i>	18
10	SIGNS, TRAFFIC SIGNALS AND ILLUMINATION	18
10.1.1	<i>Description</i>	18
10.1.2	<i>Mitigation, Avoidance and BMPs</i>	18
11	FISH PASSAGE RESTORATION/IMPROVEMENT	19
11.1.1	<i>Description</i>	19
11.1.2	<i>This Activity Includes</i>	19
11.1.3	<i>Mitigation, Avoidance and BMPs</i>	19
12	FUELING	19
12.1.1	<i>Description</i>	19

13	VEHICLE WASHING	20
13.1.1	<i>Description</i>	20
13.1.2	<i>Mitigation, Avoidance and BMPs.....</i>	20
14	WATER QUALITY FACILITIES	20
14.1.1	<i>Description</i>	20
14.1.2	<i>Mitigation, Avoidance and BMPs</i>	20
15	GRAVEL ROAD MAINTENANCE	20
15.1.1	<i>Description</i>	20
15.1.2	<i>Mitigation, Avoidance and BMPs.....</i>	20
16	GUARDRAILS AND CABLE BARRIERS	21
16.1.1	<i>Description</i>	21
16.2	Repair and Replacement	21
16.3	Cleaning.....	21
17	HAZARDOUS MATERIAL SPILL MITIGATION	22
17.1.1	<i>Description</i>	22
18	SHOULDER MAINTENANCE AND REPAIR	22
18.1.1	<i>Description</i>	22
18.2	Shoulder Blading and Rebuilding	22
18.3	Erosion Repair	23
19	SLIDES AND SETTLEMENTS	23
19.1.1	<i>Description</i>	23
19.1.2	<i>Mitigation, Avoidance and BMPs.....</i>	24
20	SNOW AND ICE MITIGATION	25
20.1.1	<i>Description</i>	25
20.1.2	<i>Mitigation, Avoidance and BMPs.....</i>	25
20.2	Sanding.....	25
21	STOCKPILES	25
21.1.1	<i>Description</i>	25
21.1.2	<i>Mitigation, Avoidance and BMPs.....</i>	25
22	STRIPING AND LEGEND MARKING	26
22.1.1	<i>Description</i>	26
22.1.2	<i>Mitigation, Avoidance and BMPs.....</i>	26

23 SURFACING	26
23.1.1 <i>Description</i>	26
23.1.2 <i>Mitigation, Avoidance and BMPs.....</i>	26
23.2 Pavement Production and Surface/Deep Base Repair	26
23.3 Release Agents	27
23.4 Void Filling	27
23.5 Chip Sealing.....	27
23.6 Pavement Grinding and Saw Cutting	27
24 SWEEPING AND FLUSHING	28
24.1.1 <i>Description</i>	28
24.1.2 <i>Mitigation, Avoidance and BMPs.....</i>	28
24.2 Non-Pickup Sweeping and Flushing	28
25 VEGETATION MANAGEMENT	28
25.1.1 <i>Description</i>	28
25.1.2 <i>Mitigation, Avoidance and BMPs.....</i>	28
25.2 Hand Cutting Trees and Brush	29
25.3 Mechanical Mowing and Limbing	29
25.4 Herbicides	30
25.4.1 <i>Broadleaf Application.....</i>	30
25.4.2 <i>Shoulder Application</i>	30
26 SPECIAL MANAGEMENT AREAS (SMAs).....	31
26.1.1 <i>Description</i>	31
26.1.2 <i>Mitigation, Avoidance and BMPs.....</i>	31
26.2 Mowing	32
26.3 Tree Cutting/Thinning and Stump Removal	32
26.4 Chemical Treatment.....	32
26.4.1 <i>Chemical Restrictions near Fender’s Blue Butterfly</i>	33
26.4.2 <i>Chemical Restrictions near Nelson’s checkermallow</i>	33
LIST OF APPENDICES	34
ADDITIONAL RESOURCES	35
IMAGE CREDITS	35

INTRODUCTION

Best Management Practices (BMPs) are intended to guide Benton County in minimizing impacts to environmental and cultural resources while maintaining infrastructure.

These BMPs are largely based on the Oregon Department of Transportation (ODOT) Routine Road Maintenance Water Quality and Habitat Guide Best Management Practices (Figure 1).

The activities detailed in this document are subject to Benton County's DSL/USACE joint permit and/or Oregon Department of Environmental Quality (OR DEQ) 1200-CA permits. The County's 1200-CA permit requires compliance with the MS4 Program while conducting construction and maintenance activities in the County Right-of-Ways.

Benton County's BMPs reference the Endangered Species Act (ESA) and incorporate guidance from the:

- ✓ **National Marine Fisheries Service (NMFS),**
- ✓ **Oregon Department of Fish and Wildlife (ODFW),**
- ✓ **Oregon Department of Environmental Quality (OR DEQ),**
- ✓ **US Fish and Wildlife Service (USFWS),**
- ✓ **Oregon Department of Agriculture (ODA),**
- ✓ **US Department of Agriculture and Plant Health Inspection Service (APHIS),**
- ✓ **Wildlife Service (WS), US Forest Service (USFS), and the**
- ✓ **State Historic Preservation Office (SHPO)**

Benton County BMPs should serve to protect and conserve salmonid and steelhead that are listed as threatened, as well as wetlands, cultural and other protected resources. They also provide the county with direction on how to minimize regulatory compliance risk.

The BMPs throughout this document directly address many of Benton County's Focus Areas and Vision, including: Community Safety; Outdoor Recreation; a Prosperous Economy; Environment and Natural Resources; Mobility and Transportation; Arts, Entertainment, Culture and History; and Food and Agriculture. They also address Core Values of Benton County's 2040 Thriving Communities Initiative: County Demographics; Vibrant, Livable Communities; Supportive People & Resources; High Quality Environment and Access; Diverse Economy that Fits; and Community Resilience.

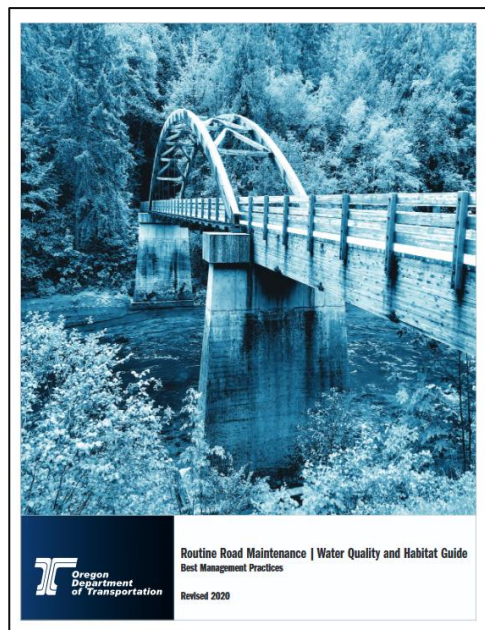



Figure 1 ODOT Water Quality and Habitat Guide BMPs

CULTURAL AND NATURAL RESOURCES


The phrases ‘to the maximum extent practicable/as possible’ are used throughout this guidebook. This guidance refers to situations where distinct requirements may not exist. Staff are encouraged to use their best judgement to mitigate environmental impacts as best as possible.

Some activities, like spraying within Special Management Areas or disrupting fish passage, have permit-related requirements that require designated permission from collaborating agencies such as ODOT, USFWS, NMFS or others. If procedures for regulated activities are unclear, please contact your Crew Lead or Department Head for direction. **Crew leads or supervisors should be aware of permit requirements while work is being planned and before it takes place.**


The lowest impact work options should be used in consideration of Benton County’s missions of sustainability and environmental stewardship. The appendices at the end of this guide, as well as the **ODOT Water Quality and Habitat Guide Best Management Practices (Blue Book)** provide further details on certain maintenance, construction, or cleaning activities.

Throughout this book, a **water drop icon ()** accompanies activities that have direct implications for **water quality and erosion and sediment control** which are further regulated by Benton County’s DEQ National Pollution and Discharge Elimination System (NPDES) permit.



Archaeological Resources

- **If archaeological material is identified during any work activity,  STOP WORK immediately.**
- Contact the project manager or the Department Head who will then coordinate with the appropriate government agency and/or tribe in order to continue work after required assessment and preservation measures.

Nesting Birds and Bat Colonies

- If work activities **will directly impact active nesting migratory birds or bat colonies,  STOP WORK immediately** and notify the Project Manager or Department Director as these species are protected.

Water Quality

	Denotes water quality , erosion and sediment control-related activities
	Denotes activities impacting fish passage and protected fish species

GENERAL GOOD HOUSEKEEPING

Mitigation and avoidance are key to Best Management Practices. BMPs in this section apply at all times.

Safety

Implementing BMPs should never take precedence over ensuring employee safety.

BMPs seek to minimize the environmental and cultural impacts of Benton County's activities. However, managers may need to exercise flexibility where possible in implementing BMP measures, particularly in consideration of employee safety.

Streams and Waterways – Best Management Practices

- **Keep debris, road materials, and chemicals out of streams.** OR DEQ prohibits introduction of any chemicals, runoff, or sediment into State waters.
- Prioritize the use of environmentally friendly products whenever possible.
- Use non-toxic structural repair materials for in-water features.
- Dampen mechanical sounds in fish-bearing streams if required by permit.
- **Use erosion and sediment measures when vegetation or ground is disturbed.** ¹ Examples include straw, mulch, geotextile fabrics, plastic sheeting, matting, sediment fence or wattles.
- Work in and around wetlands requires extreme care and DEQ, DSL, ODFW, USACE, or USFWS permits may apply.



Vegetation – Best Management Practices

- Protect existing vegetation at all times, including implementing low-impact development practices.
- Use environmentally friendly (e.g. [DEQ-approved](#)) herbicide/insecticide products and application methods.
- Perform work in a manner that minimalizes any impact to water quality or vegetation.
- Be aware of regulations and approved protocols while working within Special Management Areas (SMAs). Consult the Special Management Areas section of this document and Benton County's Prairie Species Habitat Conservation Plan (HCP) for guidance.

¹ Appendix F: [In Water Work Period & ODOT Erosion Control Manual References](#) and Appendix G: [ODOT Erosion Control Manual](#)

BEST MANAGEMENT PRACTICES

1 ATTENUATOR MAINTENANCE ²

1.1.1 Description

Impact attenuators are physical systems placed along exit ramps, bridge abutments, etc. to reduce damages to infrastructure, vehicles and motorists resulting from a crash. Attenuators compact upon impact, sometimes releasing fluid that may flow into drainage systems or waterways. Attenuator maintenance includes repair, replacement, and restoration of these systems for the safety of the traveling public.

1.1.2 Mitigation, Avoidance and BMPs:

- Use non-chemical systems when installing new attenuators.
- Install and use the most environmentally sound devices.
- Use absorbent materials (dams, diapers, etc.) around attenuators during repair or maintenance.
- Identify and close inlets during attenuator maintenance if this can be done safely.

2 BRIDGE CLEANING AND MAINTENANCE

2.1.1 Description





This activity includes maintaining bridges and culverts in a way that minimizes impacts to natural and cultural resources. Work may include: jet rodding of drain holes; weeps and scuppers; drift removal; maintenance of bridges and large culverts (greater than 3ft diameter); sweeping/shoveling debris off bridge decks; pressure washing deck, rails and under supports while capturing runoff and sediment or discharge; and painting, scraping or patching curbs, rails, deck joints, or concrete and steel bridge components.



ODFW and NMFS fish passage requirements must be adhered to when performing many of these activities. Some activities that impact fish-bearing water bodies may require additional permits.


2.2 Drift Removal

- Remove drift during the in-water work window (*see Appendix F*).
- Turn, or cut and turn, and allow drift to float.
- Use environmentally-friendly bar oil when cutting over water.
- Remove drift when necessary; place above the Ordinary High Water Line (OHWL) or further downstream to float.

- Materials should be cleaned up at the source and handled/disposed of using erosion and sediment control protocols.³
-  • Materials **should not** be allowed to enter the water.
- Stabilize material in a timely manner, including:³
 - Spreading and top seeding;
 - Covering with matting or straw;
 - Hauling away and managing any material that cannot be stabilized above the OHWL.
-  • **Repair and restore riparian areas impacted by machinery.**³

2.3 Bridge Cleaning


2.3.1 Pressure Washing

-  • Temporarily block deck drains and scuppers when pressure washing, sandblasting, or scraping to route water off deck and into vegetated areas.⁴
- Remove debris in a way that prevents material from entering waterbodies, including removing large debris with a sweeper or a shovel.
- Other material may be scraped by hand and collected before pressure washing.
- Prevent paint overspray with a shield.
- Pressure wash only at times of high water using low volume, high pressure water.

2.3.2 Sweeping

- When sweeping, collect material and dispose of away from the bridge/water.
- Stop pressure washing if paint chips have the potential to enter the stream. Set-up containment to collect paint chips.
- Position broom so that material is swept towards the end of the bridge deck onto the vegetated shoulder.

2.3.3 Bird Nests

- Inactive bird nests (empty nests that do NOT have eggs or chicks) may be cleaned off at any time.
-  • If bridge washing activities **will directly impact active bird nests or bat colonies**, ● **STOP WORK immediately** and notify the Project Manager or Department Head.

2.3.4 Fish

- Mimic natural stream channel conditions.

 ³ Appendix A: Erosion and Sediment Control Details ([DET5100](#), [DET5101](#), [DET6100](#), [DET6101](#), [DET6102](#), [DET6103](#))

 ⁴ Appendix A: Erosion and Sediment Control Details ([RD1010](#), [RD1015](#))

- Minimize or eliminate jumps created during cleaning. Adhere to ODFW fish passage guidelines and permits.
- Repair damage to existing fish passage modifications.
- Repair damage to the bridge that may have occurred during cleaning.

3 BRIDGE REPAIR ⁵

3.1.1 Description

Repair bridges and large culverts (greater than 3ft diameter) while minimizing impacts to natural and cultural resources. Includes repair or replacement of riprap, bridge drainage features, and catch basins and replacement of structural components.

3.1.2 Mitigation, Avoidance and BMPs

- **Coordinate bridge repairs with the in-water work window if access within the channel is required. Permits may be required – check with Benton County Engineering.** ⁶
- **Concrete spilled into a waterway is virtually impossible to clean up and toxic for fish and wildlife.** Ensure that concrete does not come into contact with water bodies - follow BMPs.⁷
- **Historic review and approval is not required for the following activities on historical bridges:**
 - Deck surface work (e.g. striping, paving, joints, epoxy overlay, patching, and deck seals);
 - Replacement of moveable bridge controls and related traffic safety systems;
 - Scour repair.

3.2 In-Water Work ⁸




- Mimic natural stream channel conditions upstream and downstream of bridge.
- Consider bio-engineering solutions for bridge repair work that requires installation of riprap.

3.3 Wildlife



- Adhere to ODFW Fish Passage permits and guidelines on fish passage solutions.
- Repair existing fish passage modifications like weirs or baffles if damage occurs during repair.
- Remove and dispose of repair material using proper environmental protocols; do not allow to enter water.

 ⁵ [2020 ODOT Routine Road Maintenance Water Quality and Habitat Guide BMPs Section 19](#)

 ⁶ [Appendix F: In Water Work Period & ODOT Erosion Control Manual References and Appendix G: ODOT Erosion Control Manual](#)

 ⁷ [Managing Concrete; Concrete Washout; Managing Concrete and Mortar; Slurry and Concrete Management](#)

 ⁸ [Appendix H: Temporary Water Management](#)

3.4 Water Quality



- Use a designated concrete truck chute clean-out area to prevent material from being deposited in riparian corridors, wetlands, or washing into a stream or wetland. ⁹



- Use cofferdams for structural repairs as appropriate. ¹⁰
- When cutting treated wood, contain chips and do not allow to enter the environment.

3.5 Piling

- Piling work must include erosion and sediment control BMP's and spill containment.
<G:\avery\Public Works\Safety\Spill Plan>
- Install floating absorbent boom when treated pile is cut for repair.
- Apply noise mitigation if required by permit.
- Use foam or other quickset material designed for in-water use to plug the void prior to using concrete, if the void is connected to a waterbody.
- Screen any intake pump per [NMFS screen criteria](#) during operation (Appendix D of this document).



4 STREAM CHANNEL MAINTENANCE ¹¹



4.1.1 Description

Stream channel maintenance includes cleaning and repair of existing channels to facilitate culvert flow, maintain the integrity of the channel structure, ensure fish passage, and minimize impacts to water quality and habitat. This activity also includes replacing riprap to restore line and grade of the channel. Vegetation may be removed during this activity.

4.1.2 Mitigation, Avoidance and BMPs



- **This activity may require a USACE and/or a DSL permit if fish are present.**
- Coordinate in-water work with NMFS or ODFW to aid fish passage, minimize sediment, and clarify in-water work windows for transitional stream reaches.
- Work in dry conditions when possible and work below OHWL only during the in-water work window.
- Communicate schedule, methods, and repairs to ODFW **at least two weeks prior** to working in ODFW/DSL sensitive areas (e.g. spawning grounds or essential salmonid habitat).
- Evaluate potential for bioengineering solutions before replacing large sections of riprap. ¹²
- Use rock types that maximize habitat function.
- Remove excess material and place above the OHWL or at approved/permitted dump sites.

⁹ Appendix A: Erosion and Sediment Control Details ([RD1070](#)), [Stormwater Construction Erosion and Sediment Control Elements](#)

¹⁰ Appendix H: [Temporary Water Management](#)

¹¹ [2020 ODOT Routine Road Maintenance Water Quality and Habitat Guide BMPs Section 10](#)

¹² Appendix A: Erosion and Sediment Control Details ([DET5100](#), [DET5101](#), [DET5102](#), [RD1055](#), [DET6017](#), [DET6100](#), [DET6101](#), [DET6102](#), [DET6103](#)), Appendix F: [In Water Work Period & ODOT Erosion Control Manual References](#), and Appendix G: [ODOT Erosion Control Manual](#)

- Manage drift using the following priorities:
 1. Turning and allow drift to float;
 2. Remove drift to riparian area outside of the channel;
 3. Remove drift and place downstream;
 4. Cut and turn drift to float;
- Handle excess material in a way that minimizes impact to protected resources.
- Stabilize material in a timely manner, including spreading and top seeding, covering with matting or straw, or other appropriate erosion or stabilization control measures.¹³
- Haul away material that cannot be stabilized above the OWHL.

5 CULVERT AND INLET CLEANING AND REPAIR¹⁴

5.1.1 Description

This section addresses activities done to restore function and to repair damaged water conveyances of ALL types, including box concrete, metal and wood culverts, siphons, catch basins and drop inlets.

Activities may also include clearing debris from culvert inlet/outlets, pump stations, and wash rack sumps, cleaning diversions, trash racks and stand pipes as well as fish passage retrofits and slip linings.

Various equipment may be used including backhoes, spider hoes, vactor or jet rodders, slip chute mechanism, draglines, conveyer belts, bobcats, suction devices (dredges), clam buckets, and shovels. Vegetation may be removed during cleaning. These activities are performed year-round in all weather.

These activities must provide for adequate hydraulic flow and to aid in fish passage while protecting against sedimentation.



Caution should be taken to reduce impacts to protected fish and their habitat. Fish passage and associated ODFW statutes ([ORS 509.585-509.610](#)) must be complied with while performing these activities. NMFS Fish Passage design criteria may also be required. Additional information is available on [ODFW's Fish Passage Website](#).



Removal of beaver dams (and other debris dams) that occurs within 20 feet upstream or downstream of the culvert to restore flow, prevent flooding, and allow for fish passage is considered culvert cleaning.


 ¹³ Appendix A: Erosion and Sediment Control Details ([DET5100](#), [DET5101](#), [DET5102](#), [RD1055](#), [DET6017](#), [DET6100](#), [DET6101](#), [DET6102](#), [DET6103](#)), Appendix F: [In Water Work Period & ODOT Erosion Control Manual References](#), and Appendix G: [ODOT Erosion Control Manual](#)

 ¹⁴ [2020 ODOT Routine Road Maintenance Water Quality and Habitat Guide BMPs Sections 8 & 9](#)



Before removing beaver dams, consult the [Beaver Dam Removal subsection](#) (next page). If work is greater than 20 feet from the end of the barrel, use the practices identified in [Section 4: Stream Channel Maintenance](#).

This activity may require a USACE permit, a DSL permit, temporary water management, fish salvage, or the need to provide fish passage. **If a permit is required, plan in advance to allow time to get permits. Acquiring the permits and scheduling fish salvage can require 75+ business days. Consult with Benton County Engineering.**

5.2 Culvert Cleaning and Debris Dam Removal

- Perform culvert cleaning during lowest stream flow possible (optimally dry) and only during the in-water work window.
- Manage streamflow to minimize turbidity.
- Install erosion control devices prior to work when flowing or stagnant water is present. ¹⁵
-  • **Minimize or eliminate jumps created that may impact fish passage.** Repair damage or modifications to the culvert (bent ends, disconnected joints, etc.) and fish passage modifications (weirs or baffles) that may have occurred during cleaning.
- Mimic natural stream conditions inside and outside of the culvert.
- Manage removed drift using the following priorities:
 1. Turning and allow drift to float;
 2. Remove drift to riparian area outside of the channel;
 3. Remove drift and place downstream;
 4. Cut and turn drift to float.
- Place excess material above the OHWL where there is no opportunity for material to reach the waterbody; haul away material which cannot be stabilized above OHWL.
- Stabilize material in a timely manner.

5.2.1 Trash Rack Maintenance/Cleaning

- Visually inspect trash rack for debris buildup.
-  • Ensure that the elevation of the stream on either side of the trash rack mimics natural stream slope to reduce impacts to fish passage. ²¹
-  • Minimize or eliminate jumps that could effect fish passage; follow fish passage permitting requirements set forth by ODFW.
- Ensure that design standards for trash racks are followed on fish-bearing streams. ²¹

 ¹⁵ Appendix A: Erosion and Sediment Control Details ([DET5103](#), [DET6012](#), [DET6017](#), [RD1030](#), [RD1031](#), [RD1032](#), [RD1033](#), [RD1040](#))

5.2.2 Beaver Dams¹⁶

Beaver dams can cause flooding on county roads and damage to other infrastructure including private property (*See next page: Beaver dam sites in Benton County*). Removal of beaver dams may not always be the best long-term solution. Coordinating with conservation partners (see '[Beaver Dam Modification Flowchart](#)') may yield options that will better control beaver activity over the long term. **When possible, mitigation should be used to allow beavers to remain onsite.**



Contact the Environmental Project Coordinator (Public Works) before taking action. The Coordinator will work with NMFS, ODFW and local watershed councils to achieve solutions and determine if a biologist needs to be present to address potential fish stranding. The Environmental Project Coordinator will coordinate installation of deterrents, dam analogs and pond levelers with ODFW if needed.



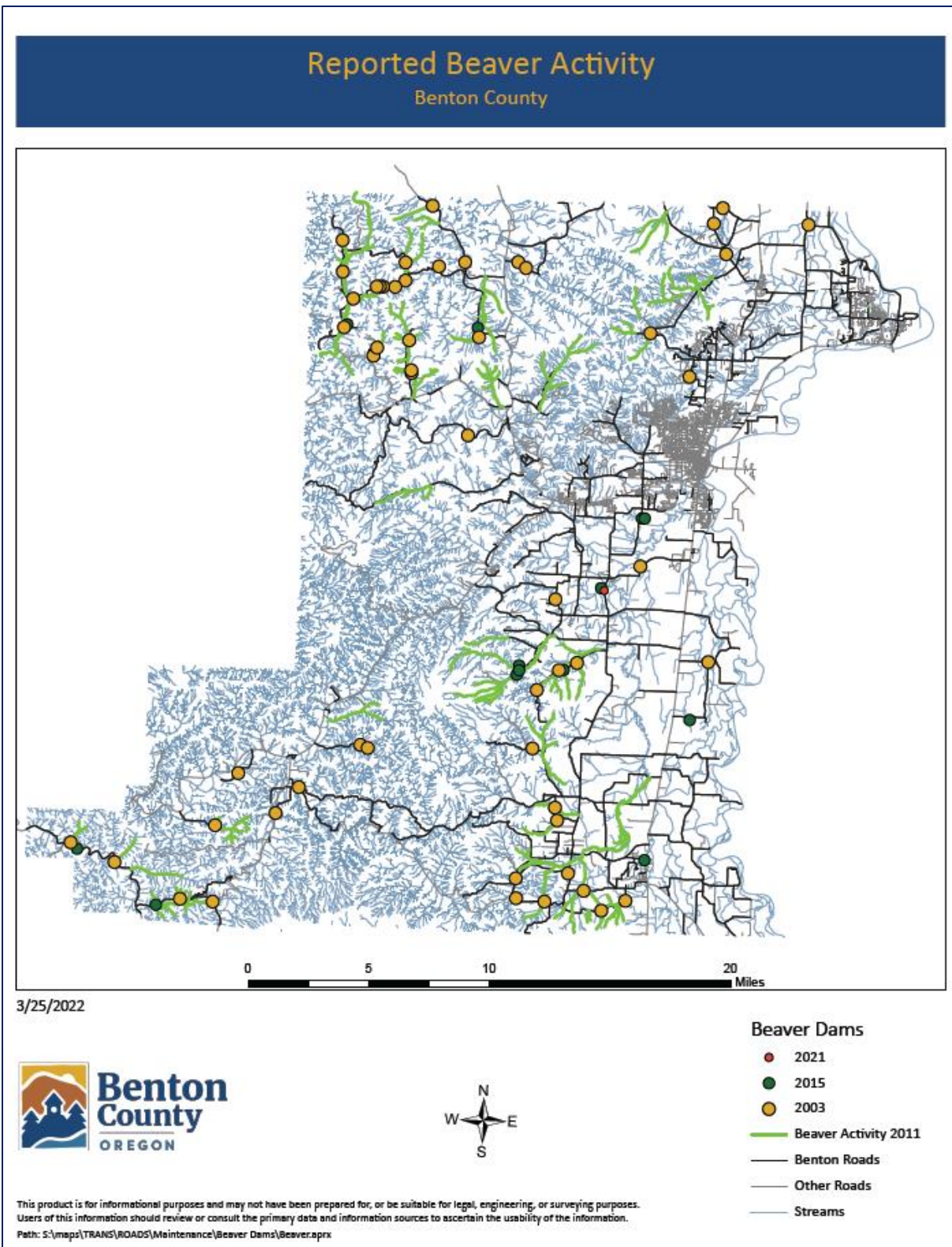
If a beaver dam must be removed, it should be done in a way that minimizes the likelihood of stranding fish, harming habitat, or adding sediment to the stream.

Remove the minimum amount of material in a slow, controlled manner to reduce risk of stranding fish. Use sediment control measures to prevent washing debris downstream.

Beaver dam material should be moved off-site or outside of the riparian area to prevent beavers from reusing it to build another dam.



ODFW must be notified if stranded fish are observed during dam removal.



Beaver dams and reported activity in Benton County. Data collected 2003, 2011 (affected watershed areas), 2015, and 2021.

5.2.3 Culvert/Inlet Repair



This activity applies to replacement and repair of drainage structures in the same location, such as culverts (less than 3ft diameter) or slip-lining. This activity may include temporary water management.

- Culvert replacement may require a permit from USACE/DSL. Replacement and some repairs will require that fish passage, fish salvage and temporary water management be addressed. Engineering and Survey can assist with questions around this.
- Conduct work during the in-water work window when appropriate (this is not always necessary, for example, on cross drains).



6 STORMWATER MANAGEMENT¹⁷

6.1.1 Description

Stormwater management aims to reduce or eliminate pollution from waterbodies.

Activities in this section include cleaning of right-of-way and catch basins, erosion control, trapping winter sanding materials, managing and maintaining ditches, stormwater inlet (catch basin) cleaning, and curb and gutter cleaning.

6.1.2 Mitigation, Avoidance and BMPs

- Consider what stormwater management measures are required when altering impervious area or existing drainage.
- Promote sheet flow to leave the road where appropriate. This may include blading or grading to re-establish flow where stormwater is being concentrated.
- Prevent discharge to receiving streams and wetlands by plugging scuppers and weep holes on bridges, installing curbing to divert water off structures, installing check dams in ditch lines, or constructing sand traps.

6.2 Construction

Construction and redevelopment activities must comply with Benton County's OR DEQ MS4 and NPDES permits.

6.3 Catch Basin Cleaning

- All agencies and contractors performing vector services for Benton County must utilize and document BMPs and submit records to Benton County including:

¹⁷ [2020 ODOT Routine Road Maintenance Water Quality and Habitat Guide BMPs Section 1](#)

1. Location
2. Date
3. Inspection report for all catch basins

6.4 Curb and Gutter Cleaning

The City of Corvallis Public Works is contracted to sweep and vactor all curb and gutters within Benton County in order to reduce pollutants washed into stormwater conveyance systems.

- Track the location and timing of sweeping in the County’s Asset Management System.
- Keep curb, gutter and stormwater infrastructure maps updated to provide maintenance details to agencies and contractors conducting street sweeping.

7 DITCH SHAPING AND CLEANING ¹⁸

7.1.1 Description

This activity includes cleaning and reshaping ditches to maintain or improve drainage and loading, hauling and disposing of excess materials (such as vegetation or soil). This activity may be performed in all types of weather with various equipment.

([Appendix I: DSL Removal-Fill Guide, Ch. 2 ‘When is a permit required?’](#))

7.1.2 Mitigation, Avoidance and BMPs ¹⁹

- Conduct this work during dry weather and lowest stream flow. ODFW consult may be required in wet season or when silt devices cannot adequately filter water draining into waterways.
- Evaluate and modify existing ditch slopes to trap sediments (short term BMP) and support permanent establishment of vegetation (long term BMP).
- Use erosion control devices to prevent sediment discharge.
- When ditching to a waterway, leave a 25’ buffer and apply an erosion control device at the beginning of the work zone to prevent leaching of sediment or water from the work site.
- When cleaning a ditch with a 10% or greater slope, install check dams every 300 feet.
- Re-seed drainage ditches and steep slopes as appropriate.
- Revegetation in Special Management Areas (SMAs) should be done with native seed or plants. ²⁰
- Do not leave materials where they can leach into a water body after a precipitation event.
- Use extreme caution to prevent fallback from entering wetlands and waters where no barrier or natural bench is present. ²¹
- Dispose of excess or removed material at permitted disposal sites.
- Reuse excess materials where feasible.

 ¹⁸ [2020 ODOT Routine Road Maintenance Water Quality and Habitat Guide BMPs Section 7](#)

 ¹⁹ [Appendix A: Erosion and Sediment Control Details \(DET6106, RD1005, RD1006\); In Water Work Period & ODOT Erosion Control Manual References; and Appendix G: ODOT Erosion Control Manual](#)

 ²⁰ [Section 20. Special Management Areas \(SMAs\); Oregon Native Plants for Erosion Control](#)

 ²¹ [Appendix A: Erosion and Sediment Control Details \(DET5100, DET5102, DET6001, RD1031\)](#)

7.2 Skip Ditching

- Protect water quality while cleaning and re-shaping roadside ditches. **Skip ditching** is a ditch maintenance process which leaves vegetation in place between areas of re-shaping so flowing water can be slowed and filtered before discharging into waterways.
- Divide lengths of ditch shaping into equal segments through the reach of a drainage ditch. Alternate segments between reshaping and leaving undisturbed vegetation.



Skip ditching in action along a rural roadway.

8 DUST ABATEMENT ²²

8.1.1 Description

Dust abatement includes the use of dust mitigation on non-paved road surfaces to temporarily stabilize soil and reduce dust during the dry season. Dust palliatives may include water, calcium magnesium acetate, magnesium chloride, or lignin sulfonates.

Dust palliatives are applied in liquid form at a maximum rate of one half gallon per square yard of surface. The rate is adjusted to be less as required to prevent puddling or runoff of the liquid solution from the road.

 ²² [2020 ODOT Routine Road Maintenance Water Quality and Habitat Guide BMPs Section 26](#)

8.1.2 Mitigation, Avoidance and BMPs

- When possible, prepare road surface prior to application of dust palliatives.
- Construct gravel berms at the low shoulders of the roadway to prevent liquid palliatives from entering waterbodies.
- **Do not apply dust palliatives within 72 hours of predicted precipitation event** (e.g. conduct this activity only before a three day forecast of sunny weather).
- Apply materials in accordance with the manufacturers' recommendations. Mix and utilize the *minimum amount needed* to prevent runoff and excess material.
- Use a 1' buffer zone on the edge of gravel if the road width allows.
- Use a 25' buffer zone near waterways or reduce application rate to prevent runoff.
- Carry spill protection and spill containment equipment.
- Use environmentally sensitive cleaning agents.
- Use all material or return to the supplier.
- **Use water alone when feasible as a primary dust palliative.**

9 EMERGENCY ROAD MAINTENANCE ²³



NOTE: If archaeological sites are known to occur in the area and repair work isn't scheduled to begin for 30 days or more, archaeological surveys should proceed if necessary. Appropriate clearance documentation should be provided prior to proceeding with repair work.

Work may require an archaeological monitor present during repair activities.

Under advisement of the Public Works Director, the Board of Commissioners determines if the event warrants a Declaration of Emergency to expedite repair work and approvals, and necessary environmental documentation/review is completed concurrently or after the fact.

The Public Works Director or County Engineer will decide if repair work must be halted to obtain necessary environmental or cultural clearances or if repair work must continue in which case clearances will be obtained concurrent with repair work or after the fact.

The Engineering Division assists with identifying environmental concerns, notifying regulatory agencies, coordinating other technical staff, and obtaining verbal approval or permits as required by the situation.

9.1.1 Description:

This activity restores and manages the transportation system in the event of natural and man-made emergencies while minimizing impact to environmental resources. It includes fixing damage to roadways, the roadside, and structures caused by storms, floods, and other events. **Failure to perform these activities may result in immediate threat to life, limb, or infrastructure.**

Emergency road maintenance activities may include: extraordinary maintenance; use of riprap; pile installation; fish passage, screening, capture and removal; temporary access roads; erosion control and site management; and drilling and boring.



This activity may require in-water work, a USACE permit, a DSL permit, temporary water management, fish salvage, archaeological clearances, and/or review and compliance with NMFS review and processes. The emergency event may trigger coordination with ODFW on the fish passage laws.

NMFS and USFWS have defined a “Natural Hazard” as an event that creates a need for an immediate (or before the next in-water work window) repair to a road, culvert, bridge or utility line to prevent imminent loss of human life, property or natural resources.

9.1.2 Mitigation, Avoidance and BMPs:



- Proceed with work to protect public and staff safety of immediate concern.
- Repair damage to fish or water resources caused by county response in coordination with USACE, DSL, ODFW, NMFS, or USFWS as appropriate.
- Avoid and/or minimize impacts to wetlands or waterbodies.
- Provide adequate erosion control and bank stabilization.
- Identify and plan for slide material storage. Identify and map long and short-term material storage sites and obtain necessary environmental clearances. ²⁴
- Use alternatives to blasting in areas with ESA-listed or protected birds.
- Refer to current SLOPES (Standard Local Operation Procedures for Endangered Species) for additional information on Major Hazard Response and USFWS Major Hazard Response Programmatic Agreement.

Other federal clearances may also be required if federal reimbursement is expected to occur after the immediate emergency threat has been addressed.

9.2 Extraordinary Maintenance

This activity includes work which is atypical and required to maintain the transportation system under circumstances outside of the control of the County while making every effort to protect natural resources. Examples include military operations, fire response, bench cleaning, and broken water line repair and cleanup.



- Follow Erosion and Sediment [BMP guidelines](#) (Section 6 of this document) to ensure sediment and other materials do not enter wetland or waterbodies.
- Repair any damage to fish habitat caused directly or indirectly by County actions.

²⁴ Appendix A. Erosion and Sediment Control Details ([DET5100](#), [DET5102](#))

9.3 Riprap – Emergency Installation

- Repair bank and bridge scours with riprap large enough to not become dislodged in high water events.
- Limit riprap to the amount of rock needed to retain structural integrity. If toe of slope must be established below the Ordinary High Water Line (OHWL).
- Above the OHWL, use appropriate size rock that is NOT open graded. Mix with soil when feasible in order to encourage plant growth.
- If riprap is used below the OHWL, use open grade rock.
- Place riprap from the top of bank or bridge when possible.
- Place rocks individually whenever equipment, time, and safety allow.
- Taper riprap size and shape above the toe.
- Plant native vegetation in riprap below and above OHWL to top of bank.
- Incorporate large wood and other bioengineering elements into slope stabilization project when appropriate and feasible.

In situations where woody vegetation and large wood cannot be incorporated into riprap, coordinate with NMFS/USFWS on developing a mitigation plan that meets the scope, scale and effects of the repair. Some potential options include: removing unwanted vegetation from immediate area and replanting with appropriate vegetation or provide resources, equipment, and services to another organization for a restoration project.

9.4 Emergency Pile Installation

- In emergency situations where pile installation is required, use a vibratory hammer when available.
- Apply noise mitigation such as bubble curtains if required by permit.
- Use steel or untreated wood as pile. Use treated timber ONLY if other materials are not available and timber will be coated/sealed.
- **Document decision making process on the use of pile and BMPs.**

9.5 Fish Passage, Screening, Capture and Removal in Emergency Circumstances



In circumstances where a culvert or other hydraulic facility must be replaced and may involve fish passage, screening, capture and/or removal, contact the County Engineering Department directly.



9.6 Emergency Establishment of Temporary Access Roads

- Minimize the number and size of entry points or access into the work area.
- Consider using geotextile fabric to protect the ground and ease cleanup.
- When work is completed, the temporary access routes shall be obliterated, removed, or mitigated.
- Stabilize soil and restore vegetation if possible.

9.7 Erosion Control and Site Management in Emergency Situations ²⁵

NOTE: Work in this section is subject to Benton County's DSL, USACE, and/or OR DEQ 1200-CA permits. The County's 1200-CA permit requires compliance with the MS4 Program while conducting construction and maintenance activities in the County Right-of-Ways.

- Flag the boundaries of the clearing limits. Do not clear ground beyond the flagged area unless circumstances change.
- If vegetation in the riparian area must be cleared, trim at ground level (not grubbed) unless noxious weeds are present.
- Minimize damage to aquatic, riparian, and terrestrial vegetation without jeopardizing worker safety.
- Minimize erosion and sediment, as appropriate for site conditions, by installing erosion control measures prior to conducting the repair. This may include, if appropriate and safe, installing measures in-channel.
- Inspect erosion and sediment control measures daily to ensure adequate function.
- Mobilize work crews to make immediate repairs to erosion controls or to install erosion controls during work or off-work hours.
- Replace or fix ineffective BMP measures immediately.
- Remove erosion and sediment control devices after stabilization of the project and vegetation.

10 SIGNS, TRAFFIC SIGNALS AND ILLUMINATION ²⁶

10.1.1 Description

These activities may include washing, locating, installing, repairing and replacing signs, traffic signals or other items to ensure that they are functional and in good repair.

10.1.2 Mitigation, Avoidance and BMPs

- Use erosion and sediment control devices when activities may affect waterbodies.
- Use untreated timber or other nontoxic alternatives when installing new sign posts.
- Review the [Special Management Areas](#) section of this document, and the [Benton County Habitat Conservation Plan](#) for special BMPs when working in SMAs.
- Use upland areas with proper containment capacity for green concrete for truck chute cleanout.
- **Clean out shall not occur on or near waterbodies.**
- **Protect inlets, catchments, wetlands and waterways from green concrete.**
- Use environmentally-sensitive chemicals to the maximum extent practicable.

 ²⁵ [Appendix A: Erosion and Sediment Control Details](#)

 ²⁶ 2020 ODOT Routine Road Maintenance Water Quality and Habitat Guide BMPs Section 14 2020 ODOT BMPs Section 14



11 FISH PASSAGE RESTORATION/IMPROVEMENT ²⁷

11.1.1 Description

Improves habitat conditions or fish passage while maintaining a safe and efficient transportation system. Activities include planting vegetation or placing large wood (e.g. logs or root wads) in or along a stream corridor. It also includes fish habitat restoration, enhancement and fish passage improvements.

NOTE: Fish passage activities require a USACE permit, a DSL permit, temporary water management, fish salvage, and/or cultural resource clearance. Follow ODFW in-water work guidelines or as coordinated with ODFW, NMFS through the Engineering and Survey Department.

11.1.2 This Activity Includes

- Installation and removal of culverts or the installation, removal, and repairs of baffles, weirs, or other systems within and adjacent to culverts for the purpose of improving fish passage.
- This activity may include the placement of large wood or other methods of fish passage improvement.

11.1.3 Mitigation, Avoidance and BMPs ²⁸

- Install erosion control devices, such as check dams, silt mats and other erosion and sediment control measures in a timely manner, including seeding and mulching with non-invasive species. Install silt fences and other devices as needed.
- Look for opportunities to plant vegetation on failing banks to slow roadbed deterioration and prevent sediment and pollutants from reaching nearby waterbodies.
- Place excess material above the Ordinary High Water Line (OHWL) where there is no opportunity for it to reach waterbodies or impact a wetland, unless otherwise directed by ODFW or NMFS.
- Stabilize material in a timely manner including spreading and top seeding; covering with matting or straw; or other erosion control and stabilization measures.
- Haul away and manage any material that cannot be stabilized above the OHWL.

12 FUELING

12.1.1 Description

This activity includes use of the diesel and gasoline fueling station located at Avery Maintenance Yard and refueling equipment out in the field. **Refuel equipment in the field at least 25 feet from waterbodies and follow Benton County vehicle fueling training and procedures.**

²⁷ [2020 ODOT Routine Road Maintenance Water Quality and Habitat Guide BMPs Section 20](#)

²⁸ [ODOT Erosion Control Manual](#); and Appendix H: [Temporary Water Management](#).

13 VEHICLE WASHING

13.1.1 Description

Equipment washing to ensure proper operation, function and safety of equipment and fleet vehicles.

13.1.2 Mitigation, Avoidance and BMPs

- Equipment will be washed in the covered wash rack area that contains an oil/water separator and settling vault. Water is discharged to a municipal sanitary sewer.
- Sediment in vault should be cleaned out quarterly or as needed.
- If any equipment must be washed outside of wash rack due to size, clean only the exterior (no engines or undercarriages) and use only clean water, no soap.

14 WATER QUALITY FACILITIES ²⁹

14.1.1 Description

This activity includes maintaining structures designed to contain stormwater runoff from county roads and facilities to ensure that these roads and facilities function as intended. Structures include detention and retention ponds, grassy swales, holding vaults, etc. and activities might include removal of sediment, vegetation, changing filter, periodic inspections or grading. Equipment used to maintain these structures include backhoes, vactors, jet rodders, handtools, etc. Specialty equipment may be used as needed.

14.1.2 Mitigation, Avoidance and BMPs ³⁰

- Dispose of excess or removed material at permitted disposal sites.
- Reuse excess materials where feasible.

15 GRAVEL ROAD MAINTENANCE

15.1.1 Description

Maintaining gravel roads includes restoring the roadway cross-slope, improving drainage, reshaping and smoothing existing surface material with a motor grader, and the placement of aggregate material on the road surface.

15.1.2 Mitigation, Avoidance and BMPs

- Perform this activity when adequate moisture is present in soil and aggregate.
- Use a five-pass process when grading: three cutting and mixing passes, then two lay-out passes.

 ²⁹ [2020 ODOT Routine Road Maintenance Water Quality and Habitat Guide BMPs Section 11](#)

 ³⁰ [Appendix A: Erosion and Sediment Control Details](#)

- Pull aggregate from the edge of road to center without going below the top of ditch.
- Place gravel four to six inches from top edge of foreslope when possible during layout.
- Keep crowns at 3% to 6% grade.
- When repairing potholes and washboarding, cut the material to a depth of 1 inch or below bottom of damaged area. Mix and lay-out material.
- Add gravel when necessary to restore road structure.
- If possible, use a roller to improve compaction.
- Utilize materials recommended by [ODOT Standard Specifications](#) whenever possible.
- Do not place rock on roads during freezing weather.
- When a gravel road intersects a paved road, modify the crown of the road 50 feet prior to the intersection to blend with the paved roadway. Push rock up to and onto the paved surface edge then back drag the material off.
- Install erosion control devices to protect sensitive resources as needed.³¹

16 GUARDRAILS AND CABLE BARRIERS³²

16.1.1 Description

This activity involves repair, replacement, and cleaning of existing guardrail and cable barrier sections, including pouring concrete pads and placing concrete barriers. Cleaning includes the removal of material from under guardrail and around posts by hand or grader mounted cleaner.

16.2 Repair and Replacement

- Install erosion control measures in unstable areas to protect the downslope during guardrail/cable barrier replacement.³³
- **Protect inlets, catchments, wetlands and waterways from green concrete. Green concrete is toxic to fish and wildlife and impossible to clean up once it has entered a waterway.**
- Match new guardrail with existing material including treated guardrail posts.
- Limit the use of creosote or other treated woods.

16.3 Cleaning

- Prevent material from entering streams or waterbodies.
- Pick up excess material rather than blading onto the bank when working near streams.
- Reuse recovered material when feasible.

 ³¹ Appendix A: [Erosion and Sediment Control Details](#)

 ³² [2020 ODOT Routine Road Maintenance Water Quality and Habitat Guide BMPs Section 16](#)

 ³³ Erosion and Sediment Control Details ([DET5103](#), [DET6007](#), [DET6010](#), [DET6012](#), [RD1045](#), [RD1050](#), [RD1065](#))

17 HAZARDOUS MATERIAL SPILL MITIGATION ³⁴



NOTE: If archaeological material is identified in the immediate vicinity of the spill, ensure the responsible party and their contractor are also notified.

17.1.1 Description

Addresses work associated with hazardous materials abandoned, leaked or spilled. Work includes identifying, testing, removing, and disposing of the involved material and restoring the site as needed.

Benton County staff are not generally trained, equipped or authorized to perform hazardous material cleanup. Allow the responsible party or cleanup contractor to conduct emergency response actions and cleanup necessary to protect human health, safety, and the environment. Facilitate or assist as directed and certified.

The entirety of Benton County's spill prevention and response can be accessed here:

<G:\avery\Public Works\Safety\Spill Plan>

18 SHOULDER MAINTENANCE AND REPAIR ³⁵

18.1.1 Description

Shoulder maintenance and repair includes restoration of unpaved shoulder sections by adding, reshaping and compacting aggregate material. This activity is done to correct rutting and buildup of materials, to remove vegetation for safety, improve drainage and prevent standing water on roadways. Activities may include shoulder blading and rebuilding, erosion control and repair of erosion-related damage; and/or riprap placement.

18.2 Shoulder Blading and Rebuilding



- Determine if there is an existing barrier or natural bench to protect waterbodies from fallback material. This barrier must be above the Ordinary High Water Line (OHWL) with adequate width to prevent movement of material during weather events. ³⁶
- If a barrier or natural bench is not present, install approved erosion and sediment control measures such as check dams in roadside ditches. ³⁷



- Blade while moisture is still present in substrate but not during the wettest part of the year.



³⁴ [2020 ODOT Routine Road Maintenance Water Quality and Habitat Guide BMPs Section 25](#)

³⁵ [2020 ODOT Routine Road Maintenance Water Quality and Habitat Guide BMPs Section 4](#)

³⁶ Appendix A: Erosion and Sediment Control Details ([DET5100](#), [DET5102](#), [DET6001](#), [RD1031](#))

³⁷ Appendix A: Erosion and Sediment Control Details ([DET5103](#), [DET6007](#), [DET6010](#), [DET6012](#), [RD1005](#), [RD1006](#), [RD1045](#), [RD1050](#), [RD1065](#))

- Evaluate the width of the blading activity and modify if needed to minimize disturbance to vegetation.
- Evaluate sites for alternatives to blading such as berming or paving shoulder.
- Take care to prevent slope failure from overly-steep ditch slopes or reduced ditch capacity.
- Treat paved shoulders the same as unpaved shoulders.
- Sweep gravel away from salmon habitat and flowing streams within 25 feet.
- Permanently stabilize soils using seeding, plants, etc.³⁸

18.3 Erosion Repair

- **This activity may require permits from USACE, SSL, or DEQ.**
- **This activity may also involve temporary water management, fish salvage, or impact habitat for protected species.**³⁹
- Consider the use of bio-engineering solutions where practical.⁴⁰
- Replace riprap during ODFW in-water work periods except during an emergency.
- Place excess material at appropriate sites above the Ordinary High Water Line (OHWL) where there is no opportunity for material to reach wetlands or other resources.
- **Uncover the minimum amount of soil necessary for each phase of the repair.**
- Install erosion and sediment control measures as soon as possible where erosion is likely to occur.⁴¹
- Plant vegetation or reinforce failing banks to prevent roadbed deterioration and reduce sediment and pollutant transport.⁴²

19 SLIDES AND SETTLEMENTS⁴³

19.1.1 Description

This activity includes slide and settlements repair by placing fill and removing material to proactively restore the roadway to prevent a catastrophic failure. This work is done to prevent emergency when a road is in danger of collapse.

 ³⁸ Appendix A: Erosion and Sediment Control Details ([DET5100](#), [DET5101](#), [DET5102](#), [DET6017](#), [DET6101](#), [DET6102](#), [DET6103](#))

 ³⁹ Appendix A: Erosion and Sediment Control Details ([DET5100](#), [DET5101](#), [DET5102](#), [DET6017](#), [DET6101](#), [DET6102](#), [DET6103](#))

 ⁴⁰ Appendix A: Erosion and Sediment Control Details ([DET5100](#), [DET5101](#), [DET5102](#), [DET6017](#), [DET6101](#), [DET6102](#), [DET6103](#))


 ⁴¹ Appendix A: Erosion and Sediment Control Details

 ⁴² Appendix A: Erosion and Sediment Control Details ([DET5100](#), [DET5101](#), [DET5102](#), [DET6017](#), [DET6101](#), [DET6102](#), [DET6103](#))

 ⁴³ [2020 ODOT Routine Road Maintenance Water Quality and Habitat Guide BMPs Section 24](#)




19.1.2 Mitigation, Avoidance and BMPs


Under advisement of the Public Works Director, the Board of Commissioners determines if the event warrants a Declaration of Emergency to expedite repair work and approvals, and necessary environmental documentation/review is completed concurrently or after the fact.

- 
The Public Works Director or County Engineer will decide if repair work must be halted to obtain necessary environmental or cultural clearances or if repair work must continue in which case clearances will be obtained concurrent with repair work or after the fact.

The Engineering Division assists with identifying environmental concerns, notifying regulatory agencies, coordinating other technical staff, and obtaining verbal approval or permits as required by the situation.

This activity may require a USACE permit, a DSL permit, temporary water management, fish salvage, archaeological clearance, and review and/or compliance with NMFS review and processes as described in [Section 9: Emergency Maintenance](#). The event may trigger coordination with ODFW regarding fish passage requirements and habitat regulations.⁴⁴

- 
 - Avoid or minimize additional impacts to wetlands or waterbodies. Mitigation may be required.
 - Provide adequate erosion control or bank stabilization to protect water quality.
 - Identify and plan for material storage as appropriate. Map long and short-term material storage sites and ensure necessary clearances for wetland, sensitive species, and archaeological impacts have been secured.⁵¹
- 
 - Prioritize bioengineering and fish and wildlife friendly solutions.
 - Consider alternatives to blasting in areas with ESA-listed or protected birds, if emergency allows.
 - Significant changes to the topography or vegetation of a riparian area must be coordinated with Benton County Engineering and regulatory agencies.
 - Follow in-water work guidelines.
 - Place excess material above the OHWL where there is no opportunity for material to reach wetlands or waterways.
- 
 - Install erosion control measures in a timely manner in areas where erosion is likely to occur, including seeding and mulching areas with non-invasive species.⁴⁵
 - If a USACE permit or DSL permit is required or the event may qualify for ER reimbursement, see [Section 9: Emergency Maintenance](#) for additional BMPs to be implemented to meet USACE requirements and to comply with the current version of SLOPES.

 ⁴⁴ Appendix A: Erosion and Sediment Control Details ([DET5100](#), [DET5101](#), [DET5102](#), [RD1045](#), [RD1050](#)), Appendix F: [In Water Work Period & ODOT Erosion Control Manual References](#), Appendix G: [ODOT Erosion Control Manual](#), and Appendix H: [Temporary Water Management](#)

 ⁴⁵ Appendix A: Erosion and Sediment Control Details

20 SNOW AND ICE MITIGATION ⁴⁶

20.1.1 Description

Removes snow and ice from the roadway while protecting natural resources. This includes sanding and/or removal of snow, ice, and slush from roadways using a snow plow, grader, loader or snow blower.

20.1.2 Mitigation, Avoidance and BMPs

- Reduce plowing speed in sensitive areas.
- Adjust blower chute to minimize blowing into sensitive areas where feasible.

20.2 Sanding

This activity involves applying abrasive material (sand) to roadway surfaces to assist with traction for safer driving, while protecting water quality and fish habitat in nearby waterbodies.

- Carefully consider using sanding material in the following areas: a) those with dust related air quality problems, and b) where there is danger of siltation in streams, shallow lakes or ponds.
- Store sanding material in a manner to minimize contamination of surface or groundwater.
- Covered storage for sanding material is preferred.
- Reduce speed when applying abrasives to minimize bounce and scatter.
- **Keep accurate application records including when, where, and quantity of sanding material used.**
- Place barriers in specific locations to capture sanding material, such as along streams or areas that drain directly to waterbodies. ⁴⁷
- Identify and create facilities to capture sanding material where opportunities present themselves.



21 STOCKPILES ⁴⁸

21.1.1 Description

Store stockpile materials (such as rock, sanding material, etc.) in a secure manner that minimizes impacts to natural and cultural resources.

Stockpiles should only be placed in permitted areas unless in case of emergency.

21.1.2 Mitigation, Avoidance and BMPs

- **Develop site plans and/or implement erosion control plans for areas in proximity to riparian areas, waterbodies, or wetlands. The plan should identify erosion and sediment control needs and ensure stability of the stockpiled material.**
- Review the appropriate procedures for management, reuse or disposal of stockpiled materials.

⁴⁶ [2020 ODOT Routine Road Maintenance Water Quality and Habitat Guide BMPs Section 22](#)

⁴⁷ [Appendix A: Erosion and Sediment Control Details \(DET5103, DET6012, RD1010, RD1015, RD1030, RD1031, RD1032, RD1033\).](#)

⁴⁸ [2020 ODOT Routine Road Maintenance Water Quality and Habitat Guide BMPs Section 2](#)

22 STRIPING AND LEGEND MARKING ⁴⁹

22.1.1 Description

This activity includes maintaining traffic markings including painting traffic lines, arrows, bike lanes, crosswalks, etc. Materials may include paint or durable products containing glass beads to provide retroreflectivity. These activities are conducted on paved surfaces during dry weather conditions. Pavement preparation may include grinding off old markings (generally less than 10%).

22.1.2 Mitigation, Avoidance and BMPs

- Use environmentally safe products when available.
- Contact the **County Safety Officer** or hazardous waste contractor prior to disposal of stripe grindings as they may be categorized as hazardous waste.
- Contain all waste from equipment clean outs and dispose of and store appropriately.

23 SURFACING ⁵⁰

23.1.1 Description

These activities are intended to repair the road base, surfaces, and shoulder to preserve a safe driving surface. These activities are performed on asphalt, concrete, and chip seal surfaces. Activities also include producing pavement materials (concrete, asphalt, chip rock), using grinding materials, deep base digging, site de-watering, fog sealing, filling voids (slab jacking), grinding and crack sealing. Nearby waterways should be protected from potential pollutants associated with surface work (such as asphalt, concrete, and release agents).


23.1.2 Mitigation, Avoidance and BMPs

- Have materials for spill containment on site.
- Capture and contain all excess materials when cleaning equipment in the yard or in the field.
- Prevent release agents and material from escaping the top of the pavement. Use limited amounts of release agents and/or capture material as necessary.

23.2 Pavement Production and Surface/Deep Base Repair

- Avoid working near populations of listed plants, wetlands, riparian corridors, or known archaeological resources as possible.
- Use commercial asphalt plants whenever feasible.

 ⁴⁹ [2020 ODOT Routine Road Maintenance Water Quality and Habitat Guide BMPs Section 13](#)

 ⁵⁰ [2020 ODOT Routine Road Maintenance Water Quality and Habitat Guide BMPs Section 3, Benton County Spill Prevention and Response Plan \(G:\avery\Public Works\Safety\Spill Plan\)](#)

- Use upland areas for truck chute cleanout and properly contain green concrete and asphalt. Do NOT clean out over waterbodies, in wetlands or within Special Management Areas (SMAs).
- **Green concrete is toxic to fish and wildlife and impossible to clean up after it has entered a water body.** Protect inlets and catchments using appropriate containment.
- Perform surface work in dry weather to minimize any runoff of potentially hazardous material.

23.3 Release Agents

- Do not use diesel fuel as a releasing or cleaning agent (except for the use of diesel as required in closed distributor bar systems).
- Use only products marketed as release agents, and use environmentally sensitive products when possible.
- For areas without engineered wash rack systems with oil/water treatment, capture the material released using plastic, sand blankets, or drip pans, etc.
- Capture, contain, or retain excess material on the pavement when cleaning equipment in the field using products containing release agents.
- Recycle or dispose of release agents and materials as directed by the Material Safety Data Sheet (MSDS) or as per the manufacturer's directions.
- Use heat sources to warm and clean tack nozzles during operations.
- Carry emergency spill kits with absorbent materials (diapers, kitty litter, shovels, etc.) to keep materials out of waterbodies.

23.4 Void Filling

- If the void is connected to a waterbody, use foam or other quickset material designed for use in water to plug the void prior to using concrete to prevent concrete from entering the waterbody.
- Utilize erosion control and spill prevention practices as necessary.

23.5 Chip Sealing

- **Use any practical means to prevent rock from entering streams.**
- Chip seal in dry weather only.
- Cover scuppers and drains prior to chip sealing on or near bridge decks.
- Remove excess gravel on bridge decks.
- Pick-up or sweep gravel away from waterbodies within 25 feet of work area.

23.6 Pavement Grinding and Saw Cutting

- Keep stockpiled grinding material removed from roadways away from drain inlets, drainage ditches and watercourses.
- Old asphalt or concrete must be recycled or disposed of as approved by County Engineer.
- AC grindings, pieces, or chunks used in embankments or shoulder material must not be allowed to enter any storm drains or watercourses.
- Install a silt fence until permanent controls are in place.
- Apply temporary perimeter controls such as inlet protection until cleanup is complete.
- Do not allow saw-cut Portland Concrete Cement (PCC) slurry to enter storm drains or watercourses.

- Residue from grinding/saw cutting operations shall be collected and contained and not allowed to flow across or be left on the surface of the pavement.
- Collect pavement dig-out material by mechanical or manual methods.

24 SWEEPING AND FLUSHING ⁵¹

24.1.1 Description

This activity includes removing materials such as sand, dirt, or non-hazardous debris from the road surface or shoulders while preventing sediment and pollutants from reaching waterbodies. Includes non-pickup and pickup sweeping and flushing of roadways. These activities are performed year-round.

24.1.2 Mitigation, Avoidance and BMPs

- Prevent materials from entering wetlands and waterbodies.
- Dispose of sweepings offsite to prevent impacts to natural resources.

24.2 Non-Pickup Sweeping and Flushing

Materials are sidecast (not recovered) under this activity.

- Schedule sweeping during damp weather to minimize dust production. If sweeping cannot be done during damp weather, use water to reduce dust as needed.
- If the road is parallel to a waterbody less than 25 feet from the fog line, slow the sweeper and broom speed and change the angle of the broom to prevent sweepings from entering the waterbody.

25 VEGETATION MANAGEMENT ⁵²

25.1.1 Description

This activity includes management of noxious weeds and unwanted vegetation around County roadways and infrastructure, including hand cutting of trees or brush, mechanical mowing and limbing, and herbicide application.

25.1.2 Mitigation, Avoidance and BMPs

- Avoid cutting if you see a nest in a tree.
- Employ erosion and sediment control measures if there is potential for sediment to enter a waterbody.
- Consider leaving downed trees for habitat restoration or bio-engineering projects.

 ⁵¹ [2020 ODOT Routine Road Maintenance Water Quality and Habitat Guide BMPs Section 5 & 6](#)

 ⁵² [2020 ODOT Routine Road Maintenance Water Quality and Habitat Guide BMPs Section 12](#)

- When mowing in riparian corridors, limit mowing to no more than 12 feet off pavement edge unless needed to maintain road function.

25.2 Hand Cutting Trees and Brush

- Remove vegetation up to 10 feet beyond guardrails to maintain visibility.
- Maintain shade trees along watercourses.
- Brush may be cut within 20 feet of either side of or under bridges.
- Only cut brush necessary to perform required maintenance.
- Trees or snags on or near a roadway/bridge that are weakened, unsound, undermined, leaning, or may fall across a roadway as exceptions to the above BMP.
- If trees providing shade or bank stabilization within 50 feet of watercourses are determined to be a risk to public safety as defined above, the trees will be removed. **Mature trees (greater than 12 in. diameter at breast height) removed will be replaced at a 2:1 ratio within the same watershed.**
- Leave cut brush in place whenever possible if it does not interfere with sight distance, drainage or safety.
- Vegetation control in Special Management Areas is addressed in [Section 25](#) of this document.

25.3 Mechanical Mowing and Limbing

- The tractor must be inspected and greased daily.
- Check the mower head twice daily on warm or hot days for wire or vegetation wrapped around it.
- Fill out the vehicle inspection sheet daily.
- Travel at the speed you are most comfortable with while mowing; production will increase with experience.
- Spring mowing consists of 1-2 passes of the mower head (3'-6'). At reduced site distance locations, multiple passes may be required. Utility locates are not always necessary during spring mowing except where Right-of-Way is narrow and utilities are close to the road. The aim is to keep grasses cut short.
- Fall and winter mowing include multiple passes with a focus on brush removal and overhanging limbs. **Utility locates are required.**
- **Do not cut or limb in landscaped areas, even in the Right-of-Way.** This requires hand cutting and attempts be made to talk with the property owner in advance.
- When cutting limbs, try to mulch vegetation as much as possible. Otherwise, return to area at the end of the work day and remove limbs/brush from roadway and ditch-line.
- Hand cutting low limbs will always improve the look of your job and keep larger debris off roadway.
- Mowing around bridges and guardrails should occur during each rotation.
- Do not lift mower head over the top of signs. **Pull mower head in and around signs to reduce the chance of damaging them.**
- Any damage to signs, pedestals, power poles, etc. must be reported to the office.
- Notify Road Manager about property damage or issues with citizens by the end of the work day.
- Row mowing does not mean to cut everything in reach. Use good judgment.

- Maintain a 2' buffer around all aboveground utilities.
- Limited mowing (3'-6') from the edge of pavement should occur April 1 through October 1.
- Mechanical brush cutting of backslope and low-hanging limbs should occur from October 1 through March 31st.
- Remove vegetation up to 10 feet beyond guardrails to maintain visibility.
Vegetation control in Special Management Areas is addressed in [Section 25](#).

25.4 Herbicides ⁵³

25.4.1 Broadleaf Application

- **Application of broadleaf herbicides will occur between May and October 15th.**
- **DO NOT apply herbicides in front of schools, bus stop waiting areas, driveways, field entrances or permitted no-spray areas or where persons are present.**
- Herbicide application will be spot treatment only with the focus on noxious weed control.
- Herbicides will not be applied within 25' of stream OHWL to protect water resources and sensitive fish species.
- Hand spraying herbicide is allowed within 25' of bridges IF: 1) removing vegetation is critical to the function of the structure 2) rain is not forecasted in the timeframe outlined on the herbicide label 3) an aquatic-approved herbicide is used.
- Any application on or over waterways will be with an approved aquatic herbicide only.
- Apply herbicides in accordance with EPA labels (this includes weather criteria and disposal of empty container).
- The herbicide truck will carry current Material Safety Data Sheets (MSDS) and labels of herbicides used in operation.
- **Keep records of** application date, amount of pesticide applied, location of application, temperature and wind-speed at the beginning and end of application.

Vegetation control in Special Management Areas is addressed in [Section 25](#) of this document.

25.4.2 Shoulder Application

- **Shoulder application of herbicides will occur April 1-June 30.**
- 2'- 6' of rock shoulders will be kept free of vegetation through the use of a foliar-active and/or soil residual herbicide. Typically this will be 2' for local roads, 4' for collector roads and 6' for arterial roads, depending on shoulder width.
- Treat under and around guardrails to minimize vegetation growth.
- Application of herbicides will cease 25' prior to crossing over a listed stream.
- Herbicides will be used in accordance with EPA labels including weather criteria and disposal.
- **DO NOT apply herbicides in front of schools, bus stop waiting areas, driveways, field entrances or permitted no-spray areas or where persons are present.**
- Carry current Material Safety Data Sheets (MSDS) and labels of herbicides used in operation.

- A record-keeping system will be maintained that documents: date, amount applied, location, temperature and wind-speed at the beginning and end of application. This information will meet or exceed Oregon Department of Agriculture requirements.
- **Application will occur April 1-June 30.**
- EXCEPTION: Identified test areas being evaluated for impacts associated with vegetative shoulders.

26 SPECIAL MANAGEMENT AREAS (SMAs)

26.1.1 Description

Management of designated Right-of-Ways where plants covered under Benton County's Prairie Species Habitat Conservation Plan (HCP) occur.

This activity may include mowing, cutting, thinning or removing tree stumps, chemical treatments (herbicides), restrictions near Fender's blue butterfly habitat and protected plant species.

Protected plants include:

COMMON NAME	OREGON CONSERVATION STATUS	FEDERAL CONSERVATION STATUS
Kincaid's lupine	Threatened	Threatened
Peacock larkspur	Endangered	Species of Concern
Bradshaw's lomatium	Endangered	Threatened
Nelson's checkermallow	Threatened	Threatened
Willamette daisy	Endangered	Endangered

In addition to the protected plants, two butterfly species are part of Benton County's HCP:

COMMON NAME	OREGON CONSERVATION STATUS	FEDERAL CONSERVATION STATUS
Fender's blue butterfly	Endangered	Endangered
Taylor's checkerspot butterfly	On Threatened and Endangered Species List	Endangered

26.1.2 Mitigation, Avoidance and BMPs

- **Upon confirmation of a new presence or populations of protected plants within a Right-of-Way, Benton County must designate a new SMA, notify ODA and apply signage within 60 working days.**
- To prevent the spread of noxious weeds and non-native plants, all equipment (hand tools, vehicles and heavy machinery) should be cleaned to remove mud and debris prior to entering the site.
- Human activities (including walking) within SMAs will be limited to minimize potential negative effects to Covered Species.
- Vehicle use should be minimized to reduce damage or mortality to covered plants and butterflies.
- Soil disturbance should be avoided to the maximum extent possible during road maintenance.
- Projects should minimize alterations to hydrology.
- Weed-free products should be used whenever possible.
- Re-vegetation of disturbed areas should be done with native grass/forb seed mixes or transplants.

- Vegetation control will be maintained in “sight distance zones” (areas required to be kept clear of obstructing vegetation for safety reasons), despite the presence of Covered Species.
- Woody plant and noxious weed encroachment should be minimized.

26.2 Mowing

- **Mowing will occur during the fall and winter (August 15 - February 28)**, after T&E plant species are outside of their active growth periods for the year.
- Set the mowing deck a minimum of 15 cm (6 in) above the ground to prevent unnecessary damage to protected plant species.
- Mowing or driving on non-paved surfaces should be avoided when soil is saturated to minimize compaction and rutting. If mowing must occur, use of rubber tracked equipment is preferred.
- **Spring mowing is only allowed where necessary to control a weed infestation involving a weed species reproduced mainly by seed (e.g., meadow knapweed), in which case up to ½ of the covered plant population may be mowed in an effort to control seed set.**
- No flail mowers will be used.

26.3 Tree Cutting/Thinning and Stump Removal

- **This activity should be conducted when Covered Species are in less sensitive life stages (August-February). During the flowering season, strong precautions should be used (e.g., marking with posts and flagging).**
- Handheld power tools may be used to remove woody vegetation.
- **No trees will be removed from Fender’s blue butterfly habitat during the flight season (March-June)**, unless a tree is deemed a hazard and immediate removal is required.
- Stump removal will occur only during dry periods.
- All cut material will be piled or chipped and spread away from any protected plants or hauled off-site for disposal.
- If activities occur during the wet season, tree debris may be left on site away from the covered plant species, until the dry season when equipment can access the work area to remove the debris.

26.4 Chemical Treatment

- Herbicides will be applied by a licensed applicator using appropriate equipment and BMPs.
- Minimize exposure of non-targeted species to herbicide spray, drift, leaching or runoff.
- Follow labeled restrictions, including limitations for use near water.⁵⁴
- Use the lowest effective nozzle pressure and minimum height recommended by the manufacturer.
- Droplet size shall be at least 500 microns.
- Do not apply herbicides when winds exceed 11 km (7 mph) or the wind limits specified by the manufacturer.
- Spray only when temperatures are below 30° C (85° F).
- Drift retardant adjuvants may only be used for boom spray applications, and must be non-toxic and applied under the above strict application requirements.
- Dyes may be used for applications to ensure complete and uniform application and to observe the amount of drift.

 ⁵⁴ Appendix E for a table of acceptable herbicides for use in Special Management Areas.

- The entirety of Benton County’s spill prevention and response can be accessed here:
<G:\avery\Public Works\Safety\Spill Plan>

26.4.1 Chemical Restrictions near Fender’s Blue Butterfly

Research indicates that populations of Fender’s blue larvae do not appear to be significantly damaged by some herbicides such as glyphosate, pendimethalin, imazapic, or fluazifop under field application conditions **when herbicides are applied in September-November (Clark et al. 2004)**. This may be because the larvae are buried in leaf litter and shielded from direct contact with these herbicides.

- **See Benton County spill prevention and response plan in the case of improper herbicide application or emergencies.**
<G:\avery\Public Works\Safety\Spill Plan>
- For non-tested herbicides, broad scale application will be limited to a portion of the occupied habitat (areas with Kincaid’s lupine that may host larvae) during the season when larvae are buried under leaf litter.
- The area allowed for herbicide application will be less in smaller populations. **Note restrictions on approved Herbicide Table, Appendix E of this document.**

26.4.2 Chemical Restrictions near Nelson’s checkermallow

In some cases, Nelson’s checkermallow does not go completely dormant in the fall and winter. Use of herbicides when this species is present requires additional precautions. As of 2022, there are sixteen Special Management Areas containing Nelson’s checkermallow, including five ‘Type 1’ SMAs.

- Plants must be shielded from herbicide drift or overspray with buckets, tree protection tubes, or other suitable material or method of application. **Application should be by hand (e.g., backpack sprayer wand) when spraying within 2 m (6 ft.) of Nelson’s checkermallow plants.**
- Exceptions to this include herbicides that do not harm Nelson’s checkermallow (such as grass-specific herbicides) and wipe-on applications that target other species and do not result in drift. **These exceptions are noted in Appendix E of this document and the Benton County HCP Table J.1.**

LIST OF APPENDICES

Appendix resources are cited in their entirety below, with a link to the online version of the document, where available. The relevant sections of the larger documents from which these materials are gathered are also provided as printable, PDF versions.

Appendix A

Oregon Department of Transportation. 2022. **Erosion and Sediment Control Details**.
<https://www.oregon.gov/odot/Engineering/Pages/Standards.aspx>

Appendix B

Oregon Department of Transportation. 2020. Routine Road Maintenance: Water Quality and Habitat Guide Best Management Practices. **Appendix F: Pesticide-Treated Wood**.
https://www.oregon.gov/odot/Maintenance/Documents/blue_book.pdf

Appendix C

Oregon Department of Transportation. 2020. Routine Road Maintenance: Water Quality and Habitat Guide Best Management Practices. **Appendix I: Beaver Dam Modification Flowchart**. https://www.oregon.gov/odot/Maintenance/Documents/blue_book.pdf

Appendix D

Oregon Department of Transportation. 2020. Routine Road Maintenance: Water Quality and Habitat Guide Best Management Practices. **Appendix D: NMFS Fish Screen Criteria**.
https://www.oregon.gov/odot/Maintenance/Documents/blue_book.pdf

Appendix E

Benton County. 2010. Prairie Species Habitat Conservation Plan. **Appendix J: Prairie Habitat Vegetation Management Guidelines (Table J.1: Approved Herbicides)**.
https://www.co.benton.or.us/sites/default/files/fileattachments/nature_areas_and_parks/page/2382/benton_county_prairie_species_hcp.pdf

Appendix F

In Water Work Period
Summarized from: ODFW. 2022. **Oregon Guidelines for timing of in-water work to protect fish and wildlife resources**.
<https://www.dfw.state.or.us/lands/inwater/Oregon%20In-water%20Work%20Guidelines%20January%202022.pdf?msclkid=6c7719e8a6c511eca3ff1bf4749751a8>

ODOT Erosion Control Manual References

Oregon Department of Transportation. 2020. Routine Road Maintenance: Water Quality and Habitat Guide Best Management Practices.

Vegetative Buffers: Pages 37-39

Seeding: Pages 39-49

Straw/Mulch/Mats: Pages 49-53, 57-62

Appendix G

Oregon Department of Transportation. 2019. **ODOT Erosion Control Manual.**

https://www.oregon.gov/odot/GeoEnvironmental/Docs_Environmental/Erosion_Control_Manual.pdf

Appendix H

Oregon Department of Transportation. 2014. ODOT Hydraulics Manual. **Chapter 18: Temporary Water Management.**

https://www.oregon.gov/ODOT/GeoEnvironmental/Docs_Hydraulics_Manual/Hydraulics-18.pdf

Appendix I

Oregon Department of State Lands. 2019. **A Guide to the Removal-Fill Process. Chapter 2: When is a permit required?**

https://www.oregon.gov/dsl/WW/Documents/Removal_Fill_Guide.pdf

ADDITIONAL RESOURCES

Clark, D., Blakeley-Smith, M., Hammond, P., Johnson, D., Kaye, T., Kelpsas, B., ... & Wilson, M. (2004). Control of *Brachypodium sylvaticum* and restoration of rare native upland prairie habitat at Butterfly Meadows, Benton County. *Final Report to Oregon State Weed Board and Oregon Department of Agriculture, Salem.*

IMAGE CREDITS

The icons used throughout this document were obtained via creative commons or TheNounProject.com. TheNounProject art credits are as follows:

- Water drop: Agenes Irwina Dhewi
- Salmon: BomSymbols
- Archaeology: MadexMade

Benton County BMP Document

2022

APPENDIX A

Erosion and Sediment Control Details

Oregon Department of Transportation (2022)

**All ODOT Details and Standards
can be found at:**

www.oregon.gov/ODOT/Engineering/Pages/Standards.aspx

Benton County BMP Document

2022

APPENDIX B

Pesticide-Treated Wood

Oregon Department of Transportation (2022)

APPENDIX F

Pesticide-Treated Wood

Oregon Department of Transportation

**Routine Road Maintenance
Water Quality and Habitat Guide Best Management Practices
2020**

This page intentionally left blank

Pesticide-Treated Wood Installation

- (A) Use of lumber, pilings, or other wood products treated or preserved with pesticidal¹ compounds may not be used below ordinary high water, or as part of an in water or over water structure, except as described below;
- (B) Pesticide-treated wood shipped to the project area must be stored out of contact with standing water and wet soil, and protected from precipitation;
- (C) Each load and piece of pesticide-treated wood must be visually inspected and rejected for use in or above aquatic environments if visible residue, bleeding of preservative, preservation-saturated sawdust, contaminated soil, or other matter is present;
- (D) Use prefabrication when possible to ensure that cutting, drilling and field preservative treatment is minimized;
- (E) When field fabrication is necessary, all cutting and drilling of pesticide-treated wood, and field preservative treatment of wood exposed by cutting and drilling must occur above the ordinary high water to minimize discharge of sawdust, drill shavings, excess preservation and other debris in riparian or aquatic habitats;
- (F) Use tarps, plastic tubs or similar devices to contain the bulk of any fabrication debris, and wipe off any excess field preservative;
- (G) All pesticide-treated wood structures, including pilings, must have design features to avoid or minimize impacts and abrasion that would deposit pesticide-treated wood debris and dust in riparian or aquatic habitats; and
- (H) Pesticide-treated wood may be used to construct a bridge, overwater structure, or an in-water structure; if all surfaces exposed to leaching by precipitation, overtopping waves, or submersion are coated with paint, opaque stain, or barrier that will be maintained for the life of the project. Coating and any painted-on field treatment must be carefully applied and contained to reduce contamination. Surfaces that are not exposed to precipitation or wave attack, such as parts of a timber bridge completely covered by a roadway wearing surface of the bridge deck, are exempt from this requirement.

¹ E.g., chromated copper arsenate (CCA), ammoniacal copper zinc arsenate (ACZA), alkaline copper quat (ACQ-B and ACQ-D), ammoniacal copper citrate (CC), copper azole (CBA-A), copper dimethyldithiocarbamate (CDDC), bromate preservatives, and oil-type wood preservatives, such as creosote, pentachlorophenol, and copper naphthenate. For alternative source of structural lumber and piling designed for industrial and marine applications, but not based on pesticide-treated wood, including silica-based wood preservation, improved recycled plastic technology, and environmentally safe wood sealer and stains, see, e.g., American Plastic Lumber (Shingle Springs, California) and Resco Plastics (Coos Bay, Oregon) for structural lumber for plastic; Plastic Pilings, Inc. (Railto, California) for structurally reinforced plastic marine products; Timbersil (Springfield, Virginia) for structural lumber from wood treated with silica-based fusion technology; and Timber Pro Coatings (Portland, Oregon) for nonpetroleum based wood sealer and stains. The use of trade, firm, or corporation name is for the information and convenience of the agency and does not constitute and official endorsement or approval of any product or service to the exclusion of other that may be suitable.

Pesticide-Treated Wood Removal

- (A) Project that require removal of pesticide-treated wood must ensure that, to the extent possible, no wood debris falls into the water. If wood debris does fall into the water, remove it immediately;
- (B) After removal, place wood debris in an appropriate dry storage site until it can be removed for the project area;
- (C) Do not leave wood construction debris in the water or stacked on the streambank at or below the ordinary high water; and
- (D) Evaluate wood construction debris removed during a project, including pesticide-treated wood pilings, to ensure proper disposal of debris.

Benton County BMP Document

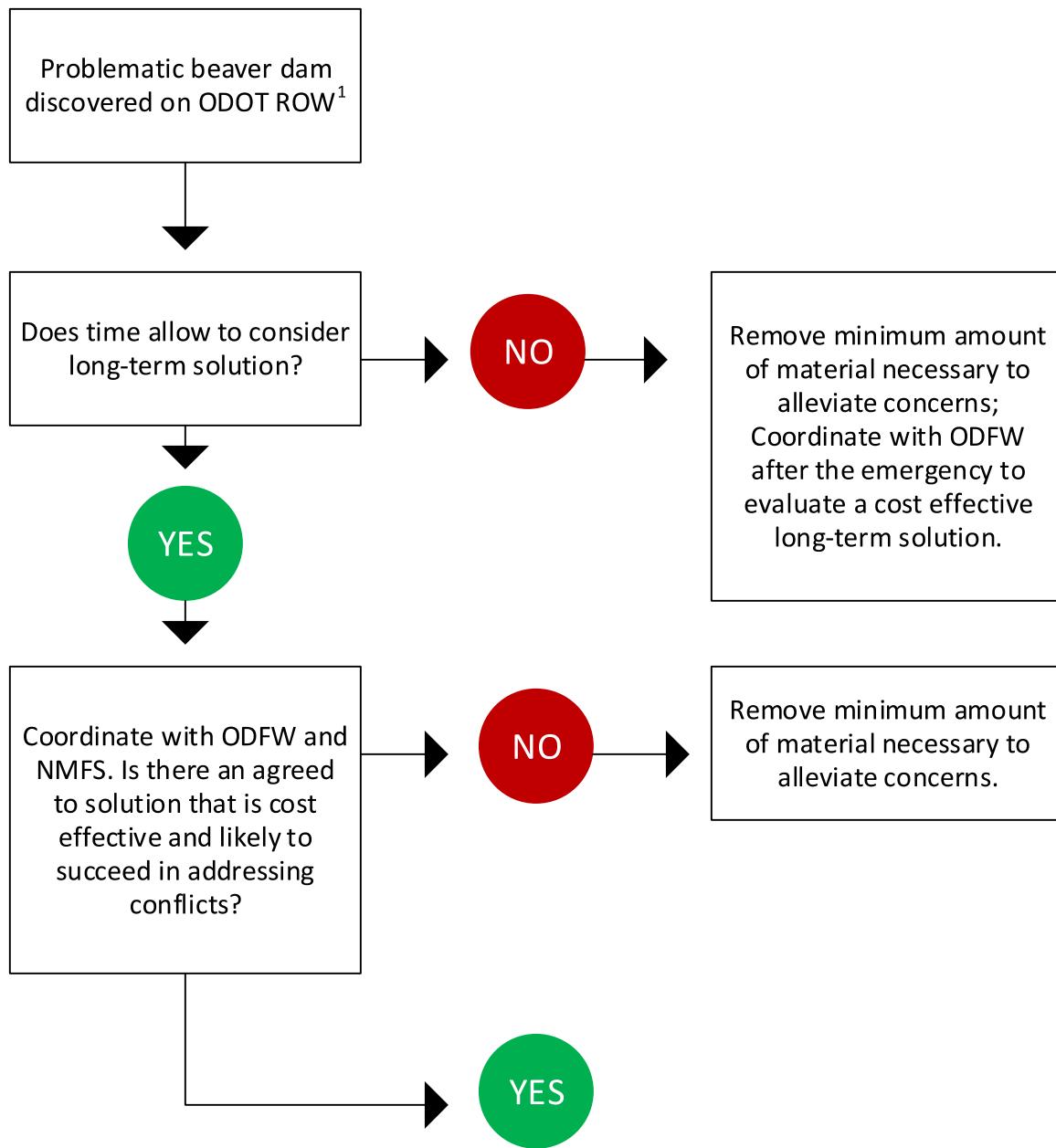
2022

APPENDIX C

Beaver Dam Modification Flowchart

Oregon Department of Transportation (2020)

Beaver Dam Modification Flowchart



¹ .Problematic beaver dams are those that cause a risk to highway safety or may damage infrastructure if left in place. ODOT may be liable for offsite flooding of private property if caused by beaver dams on ODOT property. ODOT, if contacted by the landowner may need to remove enough to alleviate the flooding. Beaver dams built in culverts (corrugated metal, box culvert, etc.),

Time allows means nothing needs to happen right away (days). If time doesn't allow, the minimum amount of beaver dam should be removed and if it's in a location that recurrence is likely, a long term solution should be evaluated after the beaver dam material is removed so that planning a solution can occur when there isn't damage occurring.

Long term solution = a device that alleviates ODOT's concerns while leaving the beaver and their dams in place. Examples are beaver deceivers and pond levelers, but could be any new technology developed.

Benton County BMP Document

2022

APPENDIX D

NMFS Fish Screen Criteria (2020)

Oregon Department of Transportation (2020)

APPENDIX D

NMFS Fish Screen Criteria

Oregon Department of Transportation

**Routine Road Maintenance
Water Quality and Habitat Guide Best Management Practices
2020**

This page intentionally left blank

NMFS Guidelines for Water Diversions when conducting Routine Road Maintenance

Created: December 15th, 2009

These guidelines are a condensed version of those guidelines relevant to ODOT's Routine Road Maintenance found within the National Marine Fisheries (NMFS) northwest region's *Anadromous Salmonid Passage Facility Design* (February, 2008):

The screening of pump intakes is required. If pumps are used to temporarily divert a stream (to facilitate construction), an acceptable fish screen must be used to prevent entrainment or impingement of small fish. At no time must construction or construction staging activity disrupt continuous streamflow downstream of the construction site.

The use of pumps and their intake design shall be designed according to the following:

Construction

- Circular Mesh Screens: openings must not exceed 3/32 inch in diameter. Perforated plate must be smooth to the touch with openings punched through in the direction of approaching flow.
- Slotted Screens: Slotted screen face openings must not exceed 1.75 mm (approximately 1/16 inch) in the narrow direction.
- Square Mesh Screens: Square screen face openings must not exceed 3/32 inch on a diagonal.
- The screen material must be corrosion resistant and sufficiently durable to maintain a smooth uniform surface for the duration of its use.
- Other Components: Other components of the screen facility (such as seals) must not include gaps greater than the maximum screen opening defined above.
- Unobstructed Screen Area: The percent open area for any screen material must be at least 27%
- No single pump may withdraw more than 3 cfs.

Placement

- If multiple pumps are used that draw >3cfs place pumps so that a single point of attraction flow does not occur.
- End of pipe screens must be placed in locations with sufficient ambient velocity to sweep away debris removed from the screen face, or designed in a manner to prevent debris re-impingement and provide

for debris removal.

- End of pipe screens must be submerged to a depth of at least one screen radius below the minimum water surface, with a minimum of one screen radius clearance between screen surfaces and natural or constructed features. For approach velocity calculations, the entire submerged effective screen area may be used.
- A clear escape route should exist for fish that approach the intake volitionally or otherwise. For example, if a pump intake is located off of the river (such as in an intake lagoon), a conventional open channel screen should be placed in the intake channel or at the edge of the river to prevent fish from entering a lagoon.
- If possible, utilize an underground infiltration gallery. Coordinate with REC to be considered.

Benton County BMP Document

2022

APPENDIX E

Vegetation Management Guidelines

***Benton County Prairie Species Conservation Plan
(2010)***

Table J.1. Approved Herbicides

Herbicide	Brand Names(s)	Surfactant or Adjuvant	Target Species	Application Period	Application Method	Restrictions
Triclophyr	Garlon		Woody species and broadleaves	February 1–August 15: wipe on applications only. August 15–October 31: spray and wipe applications. August 15–April 1: Applications in areas with Nelson’s checkermallow, provided restrictions are followed	Woody Species: Hand painted or directly wicked onto fresh cut stumps within 24 hours of cutting. Broadleaf Species: Apply using a hand-held wand or mounted on an all-terrain vehicle.	Fender’s blue butterfly: Do not spray over Kincaid’s lupine where Fender’s blue is present
Glyphosate	Rodeo, Round-up, Aqua-Master, Accord	Vegetable oil based surfactant	Grasses and broadleaves, some woody species including blackberry	February 1–August 15: wipe on applications only. August 15–October 31: spray and wipe applications. August 15–April 1: Nelson’s checkermallow, provided precautions are followed	Apply with a hand-held wand or boom mounted on an all-terrain vehicle.	Nelson’s checkermallow: No covering of Nelson’s checkermallow is required where glyphosate is applied with a weed wipe (target upper grass stems, avoiding Nelson’s checkermallow plants.) Fender’s blue butterfly: Apply in fall with an all-terrain vehicle boom mounted sprayer or via spot treatment of target plants.
Imazapic	Plateau	Vegetable oil based surfactant	Grasses and broadleaf sp. (pre- and post-emergent)	September 1–November 30: Spray or wipe on.	Apply with a hand-held wand or boom mounted on an all-terrain vehicle.	Fender’s blue butterfly: Apply in fall with an all-terrain vehicle boom mounted sprayer or via spot treatment of target plants.

Herbicide	Brand Names(s)	Surfactant or Adjuvant	Target Species	Application Period	Application Method	Restrictions
Pendimethalin	Pendulum		Grasses and broadleaf sp. (pre-emergent)	September 1- November 30: Spray on	Apply with a hand-held wand or boom mounted on an all-terrain vehicle.	Control germination of seeds; will not harm established plants. Fender's blue butterfly: Apply in fall with an all-terrain vehicle boom mounted sprayer or via spot treatment.
2,4-D amine	Weedar 64	Vegetable oil based surfactant	Broadleaf sp.	February 1 – August 15: wipe on applications only. August 15 – October 31: spray and wipe applications. August 15- April 1: Nelson's checkermallow, provided precautions are followed.	Apply with a hand-held wand or boom mounted on an all-terrain vehicle..	Fender's blue butterfly: With areas supporting 100 adult FBB, the area to be treated will be no more than 1/3 of the occupied habitat. For sites supporting fewer than 100 adult FBB, the area to be treated will be no more than 1/4 of the occupied habitat.
Clethodim	Envoy	Vegetable oil based surfactant	Non-native grasses	June 1 – October 25: upland prairie. August 1 – October 25: Wet Prairie.	Apply with a hand-held wand or boom mounted on an all-terrain vehicle. Weed wiping during the growing season near covered plants should target taller grasses, avoiding low-stature plants.	Nelson's checkermallow: No covering of Nelson's checkermallow is required. Fender's blue butterfly: With areas supporting 100 adult FBB, the area to be treated will be no more than 1/3 of the occupied habitat. For sites supporting fewer than 100 adult FBB, the area to be treated will be no more than 1/4 of the occupied habitat.
Sethoxydim	Poast	Vegetable oil based surfactant	Grasses	Upland Prairie: June 1 – October 25 Wet Prairie: August 1 – October 25 General: February 15 – May 15 (early application)	Apply with a hand-held wand or boom mounted on an all-terrain vehicle.	Nelson's checkermallow: No covering of Nelson's checkermallow is required. Fender's blue butterfly: With areas supporting 100 adult FBB, the area to be treated will be no more than 1/3 of the occupied habitat. For sites supporting fewer than 100 adult FBB, the area to be treated will be no more than 1/4 of the occupied habitat.

Herbicide	Brand Names(s)	Surfactant or Adjuvant	Target Species	Application Period	Application Method	Restrictions
Fluazifop-P-butyl	Fusilade	Vegetable oil based surfactant	Grasses	Upland Prairie: June 1 – October 25 Wet Prairie: August 1 – October 25 General: February 15 – May 15	Spot foliar application using a hand-held wand or mounted on an all-terrain vehicle. If weed wiper is used to apply Fluazifop-P-butyl near listed or covered plants during the growing season, the herbicide shall be applied at a height to target the upper grass stems and avoid lower stature listed and/or covered plant species.	Nelson's checkermallow: No covering of Nelson's checkermallow is required. Fender's blue butterfly: Apply in the fall or winter with an all-terrain vehicle boom mounted sprayer or via spot treatment.
Oryzalin	Surflan	Activator 90	Grasses	Upland Prairie: August 1 – October 31	Broadcast spray application using a backpack sprayer with a hand-held wand.	Nelson's checkermallow: Protect plants from herbicide drift or overspray (species does not go dormant), cover using buckets, tree protection tubes, or other suitable material that covers or shields the plants. Fender's blue butterfly: Apply in the fall with an all-terrain vehicle with boom sprayer or via spot treatment. With areas supporting 100 adult FBB, the area to be treated will be no more than 1/3 of the occupied habitat. For sites supporting fewer than 100 adult FBB, the area to be treated will be no more than 1/4 of the occupied habitat.

Benton County BMP Document

2022

APPENDIX F

Timing of In-Water Work

Oregon Department of Fish & Wildlife (2022)



IN-WATER WORK PERIOD FOR LOCAL RIVERS AND ASSOCIATED TRIBUTARIES

Alsea River	July 1 – August 31
Frazier Creek	July 1 – October 31
Jackson Frazier Ditch	July 1 – October 31
Long Tom River	July 1 – October 31
Luckiamute River	July 1 – October 31
Mary’s River	July 1 – October 31
Sequoia Creek	July 1 – October 31
Stewart Slough	July 1 – October 31
Willamette River	July 1 – October 31

<https://www.dfw.state.or.us/lands/inwater/Oregon%20In-water%20Work%20Guidelines%20January%202022.pdf?msclkid=6c7719e8a6c511eca3ff1bf4749751a8>

VEGETATIVE BUFFERS / SEEDING / STRAW / MULCH / MATS
(REFERENCES TO ODOT EROSION & SEDIMENT CONTROL MANUAL)

https://www.oregon.gov/odot/GeoEnvironmental/Docs_Environmental/Erosion_Control_Manual.pdf

BMP	PAGES
Vegetative Buffers.....	37-39
Seeding.....	39-49
Straw / Mulch / Mats.....	49-53, 57-62

Benton County BMP Document

2022

APPENDIX G

ODOT Erosion Control Manual
Oregon Department of Transportation (2019)



EROSION CONTROL MANUAL
GUIDELINES FOR DEVELOPING AND IMPLEMENTING
EROSION AND SEDIMENT CONTROLS
Delivery & Operations Division | Engineering &
Technical Services Branch
April 2023

ODOT is an Equal Employment Opportunity and Affirmative Action Employer.

This information can be made available in alternative format by contacting (ENTER phone number of division, section or person responsible for the publication).

ODOT does not discriminate on the basis of disability in admission or access to our programs, services, activities, hiring and employment practices. Questions: 1-877-336-6368 (EEO-ODOT) or through Oregon Relay Service at 7-1-1.

Oregon Department of Transportation

Statewide Project Delivery Branch – Engineering & Technical Services Branch

Geotechnical Engineering & Engineering Geology Section

4040 Fairview Industrial Dr. SE MS 6

Salem, OR 97302

Office: (503) 986-3252

Fax: (503) 986-3249

<https://www.oregon.gov/odot/GeoEnvironmental/Pages/Erosion.aspx>

TABLE OF CONTENTS

TABLE OF CONTENTS..... 3

SUMMARY OF CHANGES 7

DISCLAIMER..... 8

ACKNOWLEDGEMENTS 9

PREFACE 10

CHAPTER 1 - EROSION PREVENTION AND SEDIMENT CONTROL 11

 1.1 INTRODUCTION 11

 1.2 BACKGROUND AND POLICIES..... 13

 1.2.1 NPDES PERMIT REQUIREMENTS 14

 1.2.2 OTHER AGENCIES AND ACTS 18

 1.2.3 DESIGNER, INSPECTOR, AND CONTRACTOR RESPONSIBILITIES..... 20

 1.2.4 AGENCY RELATIONSHIPS 24

CHAPTER 2 - EROSION PROCESSES 25

 2.1 CONCEPTS OF EROSION AND SEDIMENTATION 25

 2.1.1 TYPES OF EROSION 26

 2.1.2 EROSION FACTORS 29

 2.2 IMPACTS OF EROSION AND SEDIMENTATION 31

 2.2.1 ENVIRONMENTAL IMPACTS 31

 2.2.2 ECONOMIC IMPACTS 32

 2.2.3 POLLUTANTS 33

 2.3 PRINCIPLES OF EROSION AND SEDIMENT CONTROL..... 37

CHAPTER 3 - EROSION AND SEDIMENT CONTROL MEASURES AND BMP'S 44

 3.1 EROSION PREVENTION AND SEDIMENT CONTROL 44

 3.2 EROSION PREVENTION 46

 3.2.1 EROSION PREVENTION BEST MANAGEMENT PRACTICES 46

 3.3 RUNOFF CONTROL PRACTICES..... 79

 3.3.1 TEMPORARY SLOPE DRAIN 80

 3.3.2 OUTLET PROTECTION 83

 3.3.3 SURFACE ROUGHENING..... 85

 3.3.4 CHECK DAM 88

EROSION CONTROL MANUAL

3.3.5 DIVERSION DIKE/DIVERSION SWALE.....	91
3.3.6 STORMWATER CONTROL:	94
3.4 SEDIMENT CONTROL PRACTICES	97
3.4.1 CONSTRUCTION ENTRANCE.....	98
3.4.2 TIRE WASH FACILITY	100
3.4.3 CONSTRUCTION ROAD/PARKING AREA STABILIZATION	102
3.4.4.....	103
3.4.5 SEDIMENT BARRIER	103
3.4.6 SEDIMENT FENCE.....	118
3.4.7 INLET PROTECTION	122
3.4.8 SEDIMENT TRAP.....	127
3.4.9 FLOCCULENT TREATMENT.....	130
3.4.10 TEMPORARY SETTLING TANKS	131
CHAPTER 4 - POLLUTION CONTROL MEASURES AND BMP'S	133
4.1 MANAGEMENT OF OTHER CONSTRUCTION SITE POLLUTANTS.....	133
4.2 ENVIRONMENTAL MANAGEMENT PLAN	135
CHAPTER 5 - EROSION AND SEDIMENT CONTROL PLANNING	136
5.1 SITE INFORMATION.....	136
5.2 DATA COLLECTION	137
5.3 TYPES OF CONSTRUCTION	137
5.4 EROSION PREVENTION VS. SEDIMENT CONTROL.....	138
5.5 ASSESSING THE PROJECT SITE	138
5.5.1 REGULATORY REQUIREMENTS.....	138
5.5.2 EXISTING CONDITIONS	139
5.5.3 CONSTRUCTION CONDITIONS.....	139
5.6 FIVE BASIC RULES	140
5.7 PROJECT SCHEDULING	140
5.8 SITE CHARACTERISTICS	142
5.9 GRADING PLAN.....	142
CHAPTER 6 - EROSION AND SEDIMENT CONTROL PLAN (ESCP) DESIGN	143
6.1 BACKGROUND.....	143
6.1.1 DESIGNER RESPONSIBILITIES.....	144

EROSION CONTROL MANUAL

6.2 PLAN PREPARATION.....	145
6.2.1 ASSESSING THE PROJECT SITE	145
6.2.2 COVER MEASURES	158
6.2.3 MATTING	160
6.2.4 TRAFFIC AREA STABILIZATION.....	160
6.2.5 DUST CONTROL	161
6.2.6 ADDITIONAL DESIGN FEATURES.....	161
6.3 DEVELOP BASE MAP	166
6.4 DEVELOP PLAN SHEETS.....	167
6.4.1 EROSION CONTROL CONSTRUCTION NOTES	168
6.4.2 EROSION CONTROL LEGEND.....	168
6.4.3 PLAN SHEET FORMAT.....	169
6.4.4 TABLE OF LOCATION PLAN SHEET FORMAT	170
6.5 DESIGNER TOOLS	171
6.5.1 SOIL SURVEY INFORMATION	171
6.5.2 CONTRACT PLANS DEVELOPMENT GUIDE/CONTRACT PLANS MANUAL.....	171
6.5.3 HYDRAULICS MANUAL	172
6.5.4 PRECIPITATION DATA.....	172
6.5.5 INTERNET SITES	172
6.6 COST ESTIMATE.....	172
6.7 SPECIFICATIONS.....	173
6.7.1 EROSION CONTROL – SECTION 00280	174
6.7.2 POLLUTION CONTROL – SECTION 00290	175
6.7.3 SEEDING – SECTION 01030.....	176
6.8 NARRATIVE	177
6.9 PROJECT DESIGN PHASES	178
6.9.1 PROJECT PLANNING AND SCOPING	178
6.9.2 DESIGN ACCEPTANCE PACKAGE (DAP).....	178
6.9.3 PRELIMINARY PLANS	178
6.9.4 ADVANCE PLANS	179
6.9.5 FINAL PLANS.....	179
CHAPTER 7 - CONSTRUCTION.....	180

EROSION CONTROL MANUAL

7.1 EROSION AND SEDIMENT CONTROL MANAGER	180
7.1.1 RAINFALL MONITORING	182
7.2 PRE-CONSTRUCTION MEETING	182
7.2.1 CONTRACTOR-MODIFIED ESCP	183
7.2.2 UP-TO-DATE ESCP	184
7.2.3 CONSTRUCTION SCHEDULE REVIEW	185
7.2.4 MONITORING FORM	185
7.3 MATERIALS	186
7.3.1 ODOT QUALIFIED PRODUCTS LIST (QPL)	186
7.3.2 SUSTAINABILITY	186
7.3.3 SEED TAGS	187
7.3.4 PURE LIVE SEED CALCULATION	188
7.3.5 WEED FREE STRAW/STRAW BALES	188
7.4 INSTALLATION	189
7.5 MEASURES DURING CONSTRUCTION	189
7.5.1 WORK RESTRICTIONS	190
7.5.2 STABILIZATION REQUIREMENTS	191
7.5.3 EROSION CONTROL EMERGENCY ITEMS	191
7.6 MAINTENANCE	192
7.6.1 SEDIMENT REMOVAL	192
7.6.2 CONSTRUCTION ENTRANCES AND PAVED AREAS	193
7.6.3 SEDIMENT DISPOSAL	193
7.7 FINISHING AND CLEANUP	193
7.8 INSPECTOR'S TOOLS	193
7.8.1 INSPECTOR CHECKLIST	193
7.8.2 WINTERIZATION	194
7.8.3 RULES OF THUMB	194
APPENDIX	196
LIST OF TABLES	196
LIST OF FIGURES	196

SUMMARY OF CHANGES

Version	Summary of changes made	Date revised
1.0	Original Manual Drafted	4/1/2005
2.0	Updated All Chapters	3/7/2019
3.0	Updated All Chapters	4/5/2023

DISCLAIMER

This Erosion and Sediment Control Manual was developed by Harza Engineering Company in cooperation with the Oregon Department of Transportation. The Manual should not be construed as policy of the Oregon Department of Transportation but as a tool to minimize impacts of erosion on construction projects. The contents of this publication should not be interpreted as necessarily representing the policies or recommendations of other referenced agencies or organizations.

The mention of trade names, products or companies does not constitute an endorsement.

This manual was most recently updated in 2023, and will be updated periodically as new practices and technologies for erosion and sediment control become available.

ACKNOWLEDGEMENTS

The project team expresses sincere appreciation to the staff of the Oregon Department of Transportation for their encouragement, cooperation, extensive review, and materials. We particularly acknowledge Frances Brindle and Paul Wirfs who worked closely with us from start to finish.

We would also like to thank Fred Wright, CPESC, for his contributions and encouragement. Technical drawings and details were provided by the Oregon Department of Transportation.

Graphic art and illustrations were produced by Jacqueline Blakeley, Gery Rudolph, Sue Silva and Magnus Bernhardt.

The project team reviewed and incorporated information from manuals produced in many other states, including California, North Carolina, Washington, and Wisconsin, and wishes to acknowledge the efforts of all organizations working to advance the field of erosion and sediment control.

Harza Project Team Members Included:

- Jonathan Bailey
- Mark Egli
- Crisand Giles
- Christine Hansen
- Scott Swanson
- Daniel Roza

PREFACE

This manual is a guide on erosion and sediment control for Oregon Department of Transportation (ODOT) personnel involved in design and construction and maintenance. [Chapter 1](#) provides an introduction, background on regulations and other agencies, ODOT policies, and the responsibilities of involved parties. [Chapter 2](#) presents information on the processes of erosion and sedimentation and associated environmental impacts. [Chapter 3](#) presents erosion and sediment control measures and Best Management Practices (BMP's). [Chapter 4](#) covers additional pollution control measures and BMP's. [Chapter 5](#) presents erosion control planning, [Chapter 6](#) presents construction implementation, and [Chapter 7](#) presents guidelines for Erosion and Sediment Control Plan (ESCP) design.

This manual presents information for the most current erosion control management practices; however, no manual is comprehensive. Information on the subject of erosion and sediment control is available from numerous other sources, and readers are encouraged to refer to the documents listed in Glossary and Reference Section.

Chapter 1 - EROSION PREVENTION AND SEDIMENT CONTROL



Figure 1-1 Fiber rolls shorten slope length and grass covers soil, preventing erosion

1.1 Introduction

The purpose of this manual is to present the Oregon Department of Transportation (ODOT) Erosion and Sediment Control program to prevent the degradation of landscapes caused by erosion and the pollution of water from sediment released by erosion. Pollution can result from the release of chemicals, waste materials, and soils into air or water. Soil that erodes from construction sites and is discharged into water is considered pollution. The term pollution control refers to methods and procedures used to prevent pollution of air and surface waters. Discharging pollution is against the law, and the laws preventing pollution are defined in the permits that allow construction.

Water pollution in the United States is regulated under the Federal Water Pollution Control Act of 1972, now known as the [Clean Water Act](#) (CWA). The CWA is in place to control point source pollution which is a discharge through a pipe, channel or other discrete source and nonpoint source pollution which is runoff from diffuse sources, such as sheet flow from pavement. Section 402 of the CWA provides the legal basis for the [National Pollutant Discharge Elimination System](#) (NPDES) permit program, which regulates point source and nonpoint source discharges.

Oregon is authorized by the U.S. Environmental Protection Agency (EPA) to implement the NPDES program through the [Oregon Department of Environmental Quality](#) (DEQ) administers

the NPDES program through Oregon Revised Statute [\(ORS\) 468B](#) prohibits the discharge of wastes into waters of the state and prohibits violations permit conditions.

The NPDES permit that regulates storm water discharges from construction projects conducted by local agencies or private entities is the 1200-C individual construction permit. Another NPDES permit regulates storm water discharges for multiple projects of similar types, this permit; the 1200-CA is used by ODOT and other agencies. The 1200-CA permit requires site specific erosion control plans for construction activities which disturb a total of 1 acre or more.

[The 1200-CA permit](#) was updated in 2022 and the guidance and rules outlined in that permit are much different than those which regulated ODOT construction projects for the previous 20 years. The Permit is one of 4 documents in this suite of updates. Also provided is the [Permit Evaluation Report \(PER\)](#). This document's purpose is to interpret the permit, explain the reasons for its rules and to provide guidance to future inspectors, and regulators on enforcement of the regulations. Another document is Attachment A. [Attachment A](#) provides guidance on providing and complying with the Environmental Management Plan (EMP) which addresses pollution prevention, and contaminated media management. The fourth document in the 1200-CA package is [Attachment B](#) which provides guidance on complying with buffer zone requirements between project work and water bodies. Familiarity with these four documents is important to all who read this manual for the understanding of the obligations and commitments ODOT pledges in permit compliance and in its stewardship of the environment.

The 1200-CA permit requires control of pollutants from construction sites, other than sediment, such as green concrete, concrete wash water, oil, gasoline and solvents. The ESCP requires, as an attachment, an Environmental Management Plan (EMP). ESCP designers need to consult with the [ODOT Haz-Mat Program](#) for to identify locations and types of pollutants at Project sites and refer to Attachment A for guidance in preparation of the EMP. In addition to Federal and State requirements, many local jurisdictions have developed storm water management programs that include erosion and sediment control requirements.

Using this manual in conjunction with ODOT [Standard Specifications and Special Provisions](#), Sections 00280 (Erosion and Sediment Control) and 00290 (Environmental Protection) and ODOT's erosion control [Standard Drawings](#), (provided in the RD1000s category) the designer can develop a project-specific erosion and sediment control plans that meets or exceeds Federal, State, and local requirements.

In order to satisfy 1200-CA requirements and prevent sediment pollution from its construction projects, ODOT requires an Erosion and Sediment Control Plan (ESCP) be submitted as part of each project's contract documents. Because construction projects take time and areas of work and nature of disturbance changes during construction, ESCP sheets must be provided for each phase of construction. The ODOT ESCP, provided in the Contract bid set of plans, is usually the ESCP used during construction. Changing site conditions during construction require that the ODOT ESCP is revised by the Contractor to keep the ESCP representative of the site conditions. Occasionally Contractors develop their own ESCP which must also satisfy the 1200-CA Permit requirements and be revised during construction to keep it representative of Project site

conditions. The ESCP is intended to provide adequate measures to minimize erosion, and to prevent sediment resulting from construction activities from leaving the project boundaries.

The ODOT ESCP consists of narrative, plans, details, EMP and specifications which combined, comprise the construction documents for erosion and sediment control. Also, the ESCP develops during the course of construction to include the inspections and monitoring reports, communications with DEQ regarding discharges and corrective actions and updates and revisions to the plans portion of the ESCP.

Once under construction, the ESCP becomes a “living document” which is added to and revised many times during the duration of the construction project. Changes to the ESCP are made to address changes to site conditions, repairs and improvements to erosion and sediment control features, corrective actions, revisions to the plans and the monitoring reports which are submitted to DEQ. Keeping the ESCP updated to represent the current status of a project and the monitoring and reporting are as important as the original contract documents ESCP.

1.2 Background and Policies

ODOT is the permittee and it is state law and ODOT policy to comply with all conditions of the 1200-CA Permits and other Federal, State, County, and City regulatory requirements.

ODOT has elected to apply the permit requirements to all projects, regardless of size, when work is near sensitive areas such as wetlands or rivers. For projects that do not disturb 1 acre of ground, Technical Services advisory [GE12-01\(a\)](#) provides guidance on how to forego parts of, or all of the 00280 Section of the Specifications yet still protect the environment. When considering the use of GE12-01(a), ground disturbance is considered work that exposes soil (not aggregates).

Sediment once it enters waterways is considered pollution. It can smother salmon nests and have lethal, sub-lethal and behavioral effects that result in a decline in aquatic organisms. Oregon's waterways host threatened and endangered species including Chinook and Coho Salmon. ODOT's compliance with 1200-CA permit requirements assures its actions do not jeopardize threatened or endangered species. Permit compliance is understood to be a conservation measures identified by the US Fish and Wildlife Service and the National Marine Fisheries Service, to avoid adverse effects to such species. Avoiding adverse impacts to endangered species is a requirement of the Federal Aid Highway Programmatic (FAHP), an agreement between multiple public agencies that is legally tied to federal funding for ODOT's construction projects. More simply, compliance with the 1200-CA requirements is important in maintaining federal funding for Agency projects.

On ODOT projects Contractors are the leads on implementing and monitoring erosion and sediment control. To keep erosion and sediment control measures, current with the contractor's methods of operation and phasing of work, the contractor is required update and revise the Bid Set Plans to incorporate information that was unknown during the ESCP design. Also, there is information provided to DEQ for permit compliance including the ESCP Cover Sheet that is not part of the Bid Set. This information which must be updated prior to beginning construction

includes contractor's personnel, certifications and schedules which are important to DEQ. These ESCP updates must be provided to the Project's Resident Engineer not later than the Pre-construction Conference.

The contractor must be aware of, and adhere to, any limitations in the work area imposed by environmental permits such as no-work-areas or timing restrictions.

General design and construction considerations are as follows:

- ODOT will plan, site, and develop roads and highways in a manner that minimizes impacts to sensitive areas such as wetlands, open water or steep slopes.
- ODOT will, during the design process and construction, take into consideration minimizing land disturbance such as clearing and grading and cut and fill to reduce erosion and sediment loss.
- ODOT will employ measures to prevent pollutant sources (including sediment) from being discharged into drainage swales, wetlands, or water bodies. Protective measures such as erosion prevention, perimeter controls, sediment barriers, check dams, buffers and "no work" areas as identified on the plans will be implemented on a project-by-project basis.
- Cut and fill slopes will be as flat as practicable and consistent with soil stability. Slopes of 1:2 or steeper may require special design.
- During construction, work should be conducted to expose the least amount of soil that is practicable. As a rule, no more soil should be exposed than can be effectively controlled.
- During construction, maintenance of erosion and sediment control facilities is required to keep them functioning effectively. Sediment removed from during maintenance must be placed in non-critical areas such as slope areas and interchange quadrants. In no instances should the removed sediment be placed in a position where subsequent rainfall could return it to the sediment control devices or drainage ways.
- Erosion and sediment control is a conspicuous expression of the contractor's respect of the environment, the project vicinity and the project's neighbors.

1.2.1 NPDES Permit Requirements

DEQ has granted ODOT permits for construction activities including clearing, grading, excavation, and stockpiling. These permits authorize these construction activities that result in the disturbance of one acre or more (or phased projects where the combined disturbance is one acre or more). ODOT holds a 1200-CA permit in each of its five regions. The 1200-CA permit regulates the discharge of stormwater from construction sites. ODOT is the permittee and is responsible with permit compliance. Under this permit ODOT or its contractor, is authorized to construct, install, modify, or operate erosion and sediment control measures. Furthermore the permittee is authorized to discharge storm water to public waters in conformance with all the requirements, limitations, and conditions set forth within the NPDES 1200-CA permit. The permit conditions require that erosion be prevented and that no sediment or turbid

storm water leaves the project site. Erosion and sediment control measures used to conform to the permit requirements are called Best Management Practices (BMP's). Unless authorized by another NPDES permit, all discharges containing sediment to public waters, or conveyances to public waters are prohibited. The primary NPDES mandated controls, limitations and plan requirements are as follows: (For complete permit [language Follow LINK](#)):

1. The permittee shall ensure that an Erosion and Sediment Control Plan (ESCP), representing each phase of construction, is prepared and implemented for each construction activity regulated by this permit.
2. The 1200-CA Permit lists 92 items that, if are applicable to the project or located on the project site, must be identified on ESCP (Subsection 15.4). These detailed site map, required controls and practices, additional controls and practices, project schedule, location and types of potential pollutants, natural buffer zones between project and waterways and several other site and construction details.
3. An ESCP Cover Sheet displaying site map, vicinity map and site and project information is a required component of the ESCP. The Cover Sheet provides an overview of the Project to DEQ but is not a part of the Contract Plans. A template for the [ESCP cover sheet](#) is accessible through the [ODOT Erosion and Sediment Control web page](#).
4. A copy of the ESCP for each construction activity will be retained on-site and made available to the DEQ upon request. Electronic versions of ESCP are acceptable.
5. The ESCP shall be developed and implemented to prevent the discharge of sediment to surface waters. Under the 1200-CA Permit the following are prohibited:
 - a. Earth slides or mud flows that leave the construction site.
 - b. Evidence of concentration flows of water causing erosion when such flows are not treated to remove sediment. Evidence includes rills, rivulets or channels. Flow to unfiltered storm water inlets will be considered "leaving the site".
 - c. Turbid flows of water leaving the construction site.
 - d. Deposits of sediment in areas that drain to unprotected storm water. Inlets with failing sediment controls due to lack of maintenance will be considered unprotected.
 - e. Deposits of sediment from the construction site on public or private streets outside of the permitted construction activity.
 - f. Deposits of sediment from the construction site on any adjacent property outside of the permitted construction activity.
 - g. Runoff from contaminated areas or discharge containing pollutants.
In the event that sediment or turbid water leaves a project site, the project will be kept in Permit compliance with prompt reporting to DEQ of the discharge and submitting a corrective action report, with photo documentation.
6. Revisions to the ESCP will be common. There are 14 triggers listed in the 1200-CA permit (Subsection 15.8) that identify activities during construction that prompt ESCP revisions. See [Section 1.2.3.3](#) regarding Contractor Responsibilities.

7. DEQ may require modifications to the ESCP at any time if the ESCP is ineffective at preventing the discharge of sediment to surface waters.
8. All sediment that leaves the site shall be cleaned up within 24 hours and placed back on the site or disposed of properly. Any in-stream clean-up shall be coordinated with the DSL
9. Under no conditions shall sediment from the construction site be washed into storm drain sewers or drainage ways.
10. Each ESCP shall include any procedures necessary to meet local erosion and sediment control requirements or storm water management requirements.

The 1200-CA permit, in Section 17, provides the requirements for site monitoring and record keeping. Among the requirements are that monitoring report submittals be submitted to DEQ through their electronic portal, Your DEQ Online (YDO).

Among the inspections required, are the following:

- On Project's initial date and once every 14 days.
- After stabilization, not less that every 14 days for one month, then once per month.
- Within 24 hours of any rain event (or snow melt) which results in runoff from the site.
- Runoff from sediment basins that capture runoff for areas that are stabilized with cementitious amendments must be monitored for pH.
- DEQ may access a project site at any time and conduct an inspection.

Monitoring reports are a required part of each monitoring inspection.

Permit Subsection 17.5 lists items required to be included in each inspection monitoring report. They are:

- The inspection date;
- The name of the site and the identification number provided by the permit registrant;
- Names, titles and contact information of the inspector;
- A summary of the inspection, including the observations of the elements of the ESCP, the location of BMPs in need of any necessary maintenance or corrective actions, the location of any BMPs that failed to operate as designed or proved inadequate for a particular application, the location of where additional BMPs are needed that did not exist at the time of inspection, visual observations of the stormwater discharges from the site, or if a discharge from the site did not occur within 24 hours of a storm event (attach date stamped photos to report);
- Any unauthorized discharges from the site;
- Any portion(s) of the site where land disturbing activities have permanently ceased or will be temporarily inactive for 14 or more calendar days;
- If complying with stabilization schedules for sites affected by unforeseen circumstances that delay the initiation and/or completion of vegetative stabilization,

document the circumstances and the schedule for initiating and completing stabilization;

- If complying with the stabilization schedules in arid, and semi-arid sites typical of Eastern Oregon (climate determination of the project site can be found on the National Climatic Data Center website), or drought-stricken areas, the beginning and ending dates of the seasonally dry period and the schedule the permit registrant will follow for initiating and completing vegetative stabilization;
- All pH sampling results of stormwater in sediment basins (sediment traps) capturing runoff from soils amended with cementitious material;
- The alternative erosion and sediment control measures and the inspection frequency for linear construction projects where some areas are stabilized while work continues in others;
- Reasons for changes or modifications to the ESCP;
- Start and end dates subject to alternative inspection frequencies listed in Section 17.3
- The weather station (rain gauge) readings or other source of information that triggered the inspection (e.g., weather conditions during the inspection, the approximate amount of precipitation, and approximate amount of precipitation during the last 24 hours);
- If the Inspector determines that it is unsafe to inspect a portion of the site or the inclement weather makes the site, or portions of the site inaccessible, the reasoning and the locations to which this condition applies must be documented;
- Each inspection report must be signed by the Inspector with the following statement: **“I certify that this report is true, accurate, and complete to the best of my knowledge, abilities, and belief”**;
- All inspection reports should be kept in chronological order at the site or at an easily accessible location (electronically is acceptable), and made available at the time of inspection or within three days upon request by DEQ (Titling the inspection reports beginning with year, month day [e.g. 2022-11-24...]); and
- All visual monitoring notes, sampling records and inspection reports must be kept for three years from project completion.

The intent of the 1200-CA permit is to protect waters of the state and sensitive areas, not to punish permittees. In the event of sediment discharge from a project site, the permittee will not be considered in violation if the discharge is promptly reported and effective corrective actions are quickly established and supporting documentation of that corrective action provided to DEQ.

The penalties for water pollution, permit condition violations or falsification of monitoring reports are as follows:

- Oregon Law ([ORS 468.140](#)) allows the Director (DEQ) to impose civil penalties up to \$10,000 per day for violation of a term, condition, or requirement of a permit.

- Under [ORS 468.943](#), unlawful water pollution, if committed by a person with criminal negligence, is punishable by a fine of up to \$25,000 or by imprisonment for not more than one year, or by both. Each day on which a violation occurs or continues is a separately punishable offense.
- Under [ORS 468.953](#) It is a Class C felony punishable by up to \$100,000 for each violation, to supply false information to an Agency, or to omit required information, knowing it is required, or to conceal or fail to file documents required by Oregon Regulatory Statutes. Under [ORS 468.946](#), a person who knowingly discharges, places or causes to be placed any waste into the waters of the State or in a location where the waste is likely to escape into the waters of the State, is subject to a class B felony punishable by a fine not to exceed \$200,000 and up to 10 years in prison.

1.2.2 Other Agencies and Acts

The ODOT planning process requires coordination with other private groups and public agencies or jurisdictions that may either have an interest in, or control of, the impacts of proposed development. This process provides a means for other stakeholders to supply input regarding erosion and sediment controls, environmentally sensitive areas, and other regulated activities.

The development of an ESCP spans the entire planning, design and construction stages of a project. To be successful, it is imperative that communication among the stakeholders be established and maintained throughout the project and in accordance with Federal, State, and local agencies and acts. Some of the principal agencies and acts are described in the following sections.

1.2.2.1 Coastal Zone Management Act

[The Coastal Zone Management Act](#) of 1972 (CZMA) established a program for States and Territories to voluntarily develop programs to protect and manage coastal resources. To receive Federal approval and implementation funding, States and Territories had to demonstrate that they had programs, including enforceable policies, sufficiently comprehensive and specific to regulate land uses, water uses, and coastal development as well as to resolve conflicts between competing uses. Resource management and protection are accomplished through State laws, regulations, permits, and local plans and zoning ordinances.

The Coastal Zone Act Reauthorization Amendments of 1990 specifically changed the state coastal programs, as well as State nonpoint source programs, by addressing nonpoint source pollution affecting coastal water quality.

1.2.2.2 Coastal Zone Act Reauthorization Amendments

In the [Coastal Zone Act Reauthorization Amendments](#) of 1990 (CZARA), Congress recognized that nonpoint pollution contributes to the degradation of coastal waters and established a new program to address this pollution source. Congress recognized that the solution to nonpoint source pollution lies in State and local action. Congress called upon States to develop and

implement state Coastal Nonpoint Pollution Control Programs (CNPCP). These involve identifying nonpoint source categories, describing Best Management Practices and adopting enforceable policies. States are also required to provide technical assistance to local governments.

The amendments strengthen the links between Federal and State coastal zone programs. This enhances State efforts to manage land use activities that degrade coastal waters. DEQ committed to the implementation of a CNPCP as part of the [Oregon Plan for Salmon and Watersheds](#).

1.2.2.3 AASHTO Highway Drainage Manual

The 2014 AASHTO Drainage Manual, Volumes 1 & 2 ([available for purchase](#) through the AASHTO bookstore) provides comprehensive and technical guidelines for all aspects of highway drainage including Erosion and Sediment Control

1.2.2.4 DSL/USACE Permits

[Section 401 of the CWA](#) requires that any applicant for a federal permit to conduct any activity that may result in a discharge to waters of the State must provide the permitting agency a certification from DEQ that the activity complies with water quality requirements and standards. A broad range of land uses commonly require DEQ 401 certification, including transportation projects. Projects in which the applicant will dredge, fill, conduct in-water work or otherwise alter a waterway require a permit from the DSL and from the USACE.

The two agencies have developed a joint permit application. Although the regulatory authorities of DSL and USACE are different, their roles, when considered together, include protecting navigable waters (and the ocean), ensuring wise and beneficial water use, maintaining and enhancing water quality, protecting fish and wildlife habitat and recreational resources, and in general, protecting the public interest.

After the DSL and USACE have received a joint permit application, they forward it to DEQ. When ODOT is preparing the permit applications, the applications are circulated to all appropriate agencies, including DEQ. The permit is reviewed by DEQ to ensure that it does not endanger Oregon's streams and wetlands and to confirm that the plans meet water quality laws and standards. Frequently, applicants are required to incorporate protective measures into their construction and operational plans, such as bank stabilization, treatment of storm water runoff, spill protection, and fish and wildlife protection.

1.2.2.5 Specifications

[ODOT Specifications](#) for erosion and sediment control are provided in the Oregon Standard Specifications for Construction and supplemental [Special Provisions](#). Specifications and Special Provisions are contract documents with high authority that define Contract requirements. The Standard Specifications, Section 00280 – [Erosion and Sediment Control](#) included in Appendix B, covers materials, installation, monitoring, maintaining, repairing and removing erosion control

measures. Special provisions modify Standard Specification Section 00280 to make it project-specific. Specifications for seeding are in Section 01030, also provided in Appendix B. The 2022 update to the 1200-CA Permit require that the seeding mix is provided as part of the ESCP. To satisfy that requirement an electronic copy of the 01030 Special Provision must be included in the ESCP.

Section 00290.30(a) – Pollution Control Measures, describes the contractor’s responsibilities related to preventing water pollution. The 00290 (a) Section also covers the contractor’s responsibility regarding control of construction site pollutants, including sediment, from contractor operations not included in the ESCP.

1.2.3 Designer, Inspector, and Contractor Responsibilities

ODOT requires an Agency’s ESCP in Contract Plans. For the development of Erosion and Sediment Control Plans in the plan set the designer establishes the parameters, identifies the risks and provides guidance on the locations and installation of erosion and sediment control facilities through all phases of the construction project. The designer must be familiar with the requirements of the NPDES 1200-CA permit and the 00280 section of the Specifications as these clearly define the scope of erosion and sediment control work. Furthermore the designer edits the Special Provisions of the Specifications to address unique conditions to the project and provides a cost estimate and list of erosion and sediment control facilities sufficient to address all anticipated and most emergency situations.

Because ODOT does not dictate a contractor’s means and methods of construction, a designer cannot fully anticipate the timing and consequences of contractor activities. The 1200-CA Permit requires information be included in the ESCP, which will not be known by the designer. That information must be entered into the ESCP by the Contractor prior to beginning construction. During construction the Contractor is delegated responsibility for erosion and sediment control and for keeping current the project’s ESCP. The Specification Sections 00280.04 and 00280.30 outline some of the Contractor’s responsibilities. ODOT, as the permittee, is ultimately responsible for compliance with permit conditions. The three principle parties involved in designing, implementing and monitoring an ESCP are the designer, inspector and contractor. Each party has specific roles and responsibilities, summarized below.

1.2.3.1 Designer Responsibilities

- For ODOT projects that disturb 20 or more acres the designers of ESCPs must hold one of the following qualifications:
 - Oregon Registered Professional Engineer.
 - Oregon Registered Landscape Architect.
 - Oregon Certified Engineering Geologist.

A qualified erosion and sediment control designer without qualifying certifications may provide ESCP designs when under the controlling oversight of the signing professional.

- Understand the permit requirements, the Standard Specifications (00280 Section) and the forces that cause erosion and sedimentation.
- Have extensive knowledge about practices, products and materials that can be used to prevent erosion and control sedimentation.
- Coordinate with ODOT Haz-Mat Program to collect information required to be included in the Environmental Management Plan (EMP).
- Provide information, required by the 1200-CA Permit to be included in the ESCP.
- Research construction project site conditions.
- Understand the requirements for Buffer Zones.
- Ensure topography and drainage are clearly delineated on ESCP.
- Understand the scope of the construction project including phasing, staging areas, borrow and disposal sites and detour facilities. Consider also the phasing and duration of construction, and consequences of working during the wet season.
- Develop Special Provisions that will address the necessary materials and practices to control erosion and contain sediment on site.
- Provide an ESCP with sufficient variety and quantity of bid items to address erosion and sediment throughout project construction.
- Regularly update designers' knowledge of the latest technology in erosion control materials and methods.
- Ensure that the specified erosion control products are available on the ODOT Conditional and [Qualified Products List](#) (QPL).

1.2.3.2 Inspector Responsibilities

- Have knowledge and understanding the processes of erosion and sediment control and familiarity with erosion and sediment control BMPs and their proper use.
- Have knowledge and understanding of the Project ESCP, EMP and Pollution Control Plan (PCP).
- Ensure the contractor submits revisions to the ESCP prior to the pre-construction meeting.
- Ensure the contractor updates the ESCP as construction progresses.
- Ensure contractor installs and maintains the erosion control facilities in compliance with plans, specifications and permits.
- Verify that specified materials are provided, specified quantities are provided and that substitutions are approved prior to installation.
- Verify contractor conducts monitoring and accurately completes monitoring reports as required. (ODOT Form [734-2361](#) Erosion Monitoring Form is provided in Appendix E).
- Verify that contractor makes changes to ESCP and PCP and ensure payment if beyond original bid estimate when necessary to control erosion.

- Know Standard Specifications for Construction, Section 00280 (Erosion and Sediment Control) and 01030 (Seeding) and the 00280 and 01030 Special Provisions for the project.
- Verify Contractor has installed BMPs correctly and is conducting necessary maintenance on erosion and sediment control facilities.
- Verify that contractor and project comply with NPDES 1200-CA Permit.
- Be familiar with Erosion Standard Drawings (RD 1000 series) and Standard Details DET 6000 series).
- Inspect slopes, drainage ways, BMPs and receiving waters and look for evidence of erosion, sedimentation, turbid runoff and BMPs that need maintenance.
- Require Contractor revise BMPs if they are not installed correctly or are not providing effective control.
- Report to regulatory agency anticipated non-compliance.
- Report to regulatory agency occurrences of turbid discharge into receiving waters or other non-compliance and include in that report the nature of the non-compliance, the cause, the remedial actions taken and the probability that the remedial actions will resolve the issue that caused the non-compliance.
- Report to regulatory agency within 24 hours any non-compliance that may endanger health or the environment.
- Verify temporary erosion and sediment control facilities are removed once permanent stabilization is established.

1.2.3.3 Contractor Responsibilities

- Be educated on the latest technology to control erosion and contain sediment.
- Have valid Erosion and Sediment Control Manager ([ESCM](#)) certification or certification from other accepted agencies.
- Have knowledge of the processes of erosion and sedimentation. Know project area's climate, soils, slopes and other factors that influence erosion and sedimentation.
- Bid on the job with full understanding of responsibilities and with intention to fulfill those responsibilities.
- Be knowledgeable of the 1200-CA permit requirements and the Specifications Sections 00280 (Erosion and Sediment Control) and 01030 (Seeding).
- Be knowledgeable about the ESCP.
- Develop a PCP that includes a site plan and narrative, describing methods of erosion and sediment control to be used to prevent erosion and sediment from contractor's operations related to disposal sites, borrow pit operations, haul roads, equipment storage sites, fueling operations and staging areas.
- Construct and install BMP's as described on the details and specifications.
- Mobilize staff to provide immediate repair to erosion control facilities.
- Minimize clearing of vegetation and look for opportunities to minimize erosion, offering ideas to ODOT inspectors for approval.
- Monitor weather and conduct inspection after each rainfall or snow melt event that results in stormwater discharge from the project site.

- Monitor site and receiving waters and inspect each erosion control devices and accurately and fully record findings on ODOT Form [734-2361](#) weekly during active construction and every two weeks during inactive periods.
 - Maintain erosion control facilities including removing sediment, repairing damaged BMP and modifying, or replacing them when needed to be provide effective functioning.
 - Report to Agency Inspector discharges of sediment into receiving waters or any other non-compliance.
 - Conduct corrective actions to repair or upgrade BMPs so no sediment leaves the project site.
 - Record repair and remediation actions on ODOT Form 734-2361.
- Revise the ESCP in the plan and on the ground, to meet conditions of construction such as phasing, timing, weather Within seven days of any of the following
- Changes to the construction plans that impact erosion and sediment control measures.
 - Changes to the stormwater control BMPs, their location, maintenance required, and any other revisions necessary to prevent and control erosion and sediment runoff.
 - An increase in construction activities to adjacent lots.
 - Other activities at the site that are no longer accurately reflected in the ESCP. This includes changes made in response to corrective actions triggered under Section 16. The ESCP does not need to be modified if the estimated dates in Section 15.4.e.viii change during the course of construction.
 - To reflect areas on the site map where operational control has been transferred (and the date of transfer) since initiating permit coverage.
 - If inspections by DEQ determine that ESCP revisions are necessary for compliance with this permit.
 - Where DEQ determines it is necessary to install and/or implement additional controls at the site in order to meet the requirements of this permit, the following must be included in the ESCP:
 - A copy of any correspondence describing such measures and requirements; and
 - A description of the controls that will be used to meet such requirements.
 - Change of contractors that will engage in construction activities on site, and the areas of the site where the contractor(s) will engage in construction activities.
 - Change of any personnel (by name and position) that are responsible for the design, installation and maintenance of stormwater control measures (see Section 15.10).
 - Change of the Certified Erosion and Sediment Control Inspector, or of their contact information and any applicable certification and training experience.

- To reflect any revisions to applicable federal, state, tribal or local requirements that affect the stormwater controls implemented at the site.
 - If a change in chemical treatment systems or chemically enhanced stormwater control is made, including use of a different treatment chemical, different dosage rate or different area of application as applicable
- Ensure that permanent seeding is performed in conformance with the seeding Specifications Section 01030.
 - Ensure vegetative cover is provided as described in Section 01030.60.
 - Remove temporary erosion control devices according to 00280.70

1.2.4 Agency Relationships

ODOT is a trusted partner with National Marine Fisheries Services (NMFS), Federal Highway Administration (FHWA), Oregon Department of Fish and Wildlife (ODFW), United States Forest Service (USFS), Oregon Department of Agriculture (ODA), Department of Environmental Quality (DEQ), United States Army Corps of Engineers (USAC) and with Native Tribes. These Agencies oversee impacts to fish, wildlife, clean water, clean air, natural landscapes and the overall health and well-being of the environment. ODOT embraces the values supported by these sister Agencies. Permit compliance reinforces ODOT's reputation as a trusted partner with regulatory agencies and other stakeholders.

Chapter 2 - EROSION PROCESSES

2.1 Concepts of Erosion and Sedimentation

Erosion is a natural process by which soil and rock material is loosened and transported. Erosion by the action of water, wind, and ice has produced some of the earth's most spectacular landscapes. Natural erosion occurs primarily on a geologic time scale, but when human activities alter the landscape, the process of erosion can be greatly accelerated. Erosion and sedimentation are different aspects of the same process. Erosion is the removal of soil and sedimentation is the placement of the dislodged soil at a different location. Erosion is easier to prevent than it is to control of sediment once it is loosed.

Vegetation protects soil. Leaving vegetation in place is good erosion prevention. Since vegetation on an undisturbed site covers and protects the soil, the removal of that vegetation increases the site's susceptibility to erosion. Disturbed land may have an erosion rate 1,000 times greater than the undisturbed rate. Even though construction requires that soil be left exposed for periods of time, proper planning and use of erosion control measures can reduce the impact of man-induced accelerated erosion.



Figure 2-1 Good Sediment Control

An understanding of the processes of erosion and sedimentation is essential in the development of successful erosion and sediment control plans. The soils, slopes, and drainage patterns of a specific site influence the potential for soil erosion from that area. Drainage from off-site onto the work area can contribute to erosion. Identifying erosion problems at the planning stage and recognizing highly erodible areas, help in selecting effective erosion control practices and estimating storage volumes needed for sediment traps and basins.

Understand the process of water on undisturbed and well vegetated ground: Rain falls on vegetation and the plants absorb the energy of the falling water. Some water is actually absorbed into plant leaves. Decomposing organic matter (thatch and duff) absorb and retain water. Once the water holding capacity of the duff layer is exceeded, the water flows onto the soil. Undisturbed soil has pore space to accept infiltration and plant roots provide conduits along which water can penetrate the soil. When both the duff layer and the soil can hold no more water, it will begin to flow slowly through the duff. This duff mat is anchored in place by living vegetation and it resists being torn apart by moving water. In an undisturbed condition where vegetation has a developed a duff layer the organic material is being incorporated into the mineral soil by chemical, physical and biological forces so that the opposite of erosion is occurring, soil is being added.

When water volume exceeds the holding capacity of the duff layer and flows on the surface as a shallow sheet, blades of grass, and plant stems still keep water velocity slow and resist erosion. Once waters join into channels in undisturbed conditions the channels are naturally armored by rocks and by thickets of riparian vegetation and the plant roots that armor and bind the soil. In high flow events the tangle of stems slows the velocity of flowing water near the shore, reducing the erosive strength of the water against the banks, even when flows mid-channel may be rapids. When living riparian vegetation is damaged by bank erosion it is self-repairing. Erosion does occur naturally, but usually at a slow pace.

It is instructive to understand how nature addressed erosion and sediment control. Nature provides soft armor to the soil surface. It stores water in an organic layer at the surface and facilitates infiltration of the water into the soil, preventing runoff. Living plants remove water from the soil and once water is flowing nature has built-in erosion prevention in place. Erosion and sediment control measures used on construction sites strive to duplicate the functions provided by natural systems.

2.1.1 Types of Erosion

Erosion results from surface processes (such as [water flow](#) or wind) that remove soil, rock, or dissolved material from one location on the earth's crust, then transport it away to another location.

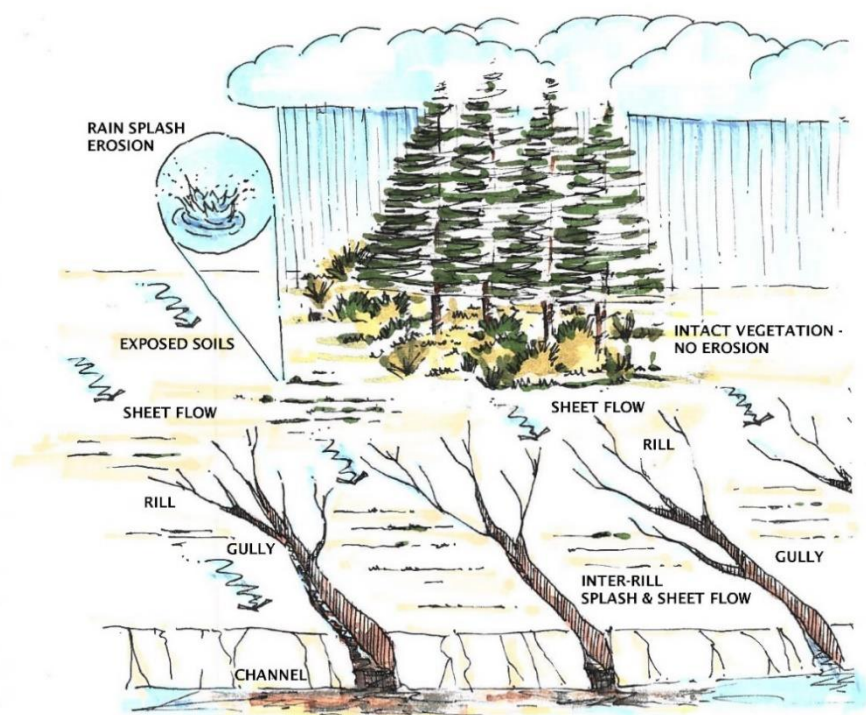


Figure 2-2 Major Types of Soil Erosion

2.1.1.1 Water Erosion

The major types of erosion are:

- **Splash** – When vegetative cover is removed, the soil surface is exposed to raindrop impact. Raindrops fall at an approximate velocity of 20 miles per hour. Raindrops hit bare soil and detach soil particles that can easily be transported by runoff. This pounding action destroys the soil structure and often a hard crust forms when the soil dries. This crust inhibits water infiltration and plant establishment, increasing runoff and future erosion.
- **Sheet** – As rain saturates soil, a thin film of water spreads across the soil surface and flows down slope in shallow sheets. This sheet flow transports soil particles that have been detached by splash erosion. Soil particles carried in sheet flow are abrasive and can dislodge more soil particles. Sheet flow rarely moves as a uniform sheet for more than a few feet before concentrating by surface irregularities.



Figure 2-3 Splash

- **Rill** – The sheet flow organizes along the low spots of the soil surface, cutting grooves called rills into the soil surface. In rills the concentrated flow moves faster and the erosive power is greater. The energy of this concentrated flow can easily detach and transport more and larger soil particles. Rills are small but well-defined channels that are only a few inches deep.
- **Gully** – Gullies are formed when stormwater runoff cuts rills deeper and wider or when several rills come together to form a gully. The erosive



Figure 2-4 Rills on a Slope

- power of water flowing in gullies can be destructive. They can deepen, widen and enlarge in both uphill (headcutting) and downhill directions. If the flow of water is sufficient, large chunks of soil can fall from a gully headwall in a process called mass wasting. Once a gully is created, erosion is very difficult to control, and damage costly to repair.
- **Channel** – Natural streams have adjusted over time to the quantity and velocity of runoff released from a watershed at a steady rate over long duration. The vegetation and rocks lining the banks are sufficient to prevent erosion under these steady-state conditions. When a watershed is altered by removing vegetation runoff volumes and velocities are increased. This change makes the flow “flashy”, meaning the watershed releases greater volumes of water over a short duration. These high fast flows are destructive beyond what a natural channel is evolved to withstand. These aggressive flows remove streambank vegetation and the bank protection it provides, resulting in channel erosion. Flashy runoff may cause expansion of gullies into well-defined channels. These changes can disturb the equilibrium of the stream. Channel erosion is commonly found at stream bends, constrictions where built structures control the stream flow, or discharge points where storm drain culverts release storm water into a stream.

2.1.1.2 Wind Erosion

Wind erosion occurs in areas of exposed, dry, sandy soils; or where the soils are loose, dry and finely granulated. Construction activity can cause in air borne sediments and blowing dust which is regulated similarly to erosion and sedimentation caused by water. Wind erosion damages land and natural vegetation by removing soil from one place and depositing it in another. Wind erosion causes deterioration of soil structure, soil nutrient losses and air pollution. Soil movement is initiated as a result of wind forces exerted against the surface of the ground. For each specific soil type and surface condition there is a minimum velocity required to move soil particles, this

is called the threshold velocity. Once the velocity is reached, the quantity of soil moved is dependent upon particle size, the cloudiness of particles, and the wind velocity.

- **Suspension** – Suspension occurs when very fine dirt and dust particles are lifted into the wind. They can be thrown into the air through impact with other particles or by the wind itself. Once in the atmosphere, these particles can be carried very high and be transported over extremely long distances. Soil moved by suspension is the most conspicuous and easiest to recognize of the three forms of movement.
- **Saltation** – In saltation, fine soil particles are lifted into the air by the wind and drift horizontally across the surface increasing in velocity as they go. Soil particles moved in the process of saltation can cause severe damage to the soil surface and vegetation. They travel approximately four times longer in distance than in height. When they strike the surface again they either rebound back into the air or knock other particles into the air. Soil in saltation acquires a negative charge relative to the ground which in turn loosens more soil. This is significant because it is primarily the saltation of sand particles which dislodges smaller dust particles into the atmosphere. Many of us have experienced saltation as sand blasting our ankles as we walk on Oregon beaches during windy days.
- **Surface Creep** – The large particles which are too heavy to be lifted into the air are moved through a process called surface creep. In this process, the particles are rolled across the surface after coming into contact with the soil particles in saltation.

Air borne dust can also be a result of trucks carrying soil with their loads not covered.

2.1.2 Erosion Factors

The four principal factors in soil erosion caused by water are: climate, soil characteristics, topography, and ground cover. These factors are interrelated in their effect on erosion potential. The variability in Oregon's climates, terrain, soils and vegetation make erosion control unique to each construction situation. Understanding the factors that affect the erosion process enables us to make useful predictions about the extent and consequences of on-site erosion. An empirical model developed for agriculture applications, the [Revised Universal Soil Loss Equation \(RUSLE\)](#), predicts soil loss resulting from splash, sheet and rill erosion. It considers both the effects of erosion control practice and the factors that influence erosion, so it is useful for evaluating erosion problems and potential solutions.

2.1.2.1 Climate

Climate affects erosion potential both directly and indirectly. In the direct relationship, rain is the driving force of erosion. Raindrops dislodge soil particles, and runoff carries the particles away. The erosive power of rain is determined by rainfall intensity (inches of rain per hour) and droplet size. A highly intense rainfall of relatively short duration and large size droplets, typical of a thunderstorm, can produce more erosion than a long duration storm of low intensity, misty rain. Oregon has considerable diversity of climate; rainfall intensity, duration Droplet sizes vary according to geographic location and type of storm. It is worth noting that climate change affects weather and this is being realized in weather extremes. Weather outcomes that are being

documented are that hot weather gets hotter, drought persists over longer periods of time and storm events can bring precipitation in unusually high volume and intensity.

2.1.2.2 Soil

A soil's vulnerability to soil erosion or erodibility is a result of a number of soil characteristics which can be divided into two groups. The first are those characteristics that influence infiltration. The second are those affecting the resistance to detachment by rainfall and runoff. Key factors that affect erodibility are soil texture, amount of organic matter, soil structure and soil permeability.

- Soil texture refers to the sizes and proportions of the particles making up a particular soil. Sand, silt, and clay are the three major classes of soil particles. Soils high in sand content are coarse-textured. Because water readily infiltrates sandy soils, the runoff, and consequently the erosion potential, is relatively low. Sandy soils are not tightly bound together so that when saturated, sandy soils are easily eroded. Soils high in content of silts and clays are said to be fine-textured or heavy. Clay, because of its stickiness, binds soil particles together and makes a soil resistant to erosion. However, once clay soils erode the fine particles are hard to remove from the water.
- Organic matter consists of plant and animal litter in various stages of decomposition. Organic matter increases permeability, water holding capacity and soil fertility. Organic matter in an undisturbed soil reduces runoff and erosion potential.
- Soil structure is the arrangement of soil particles into aggregates. Soil structure affects the soil's ability to absorb water. When the soil is compacted, as is done with roadway construction, water tends to run off rather than infiltrate. Erosion hazard increases with increased runoff. A granular structure is the most desirable one. Loose granular soils absorb and retain water, which reduces runoff and encourages plant growth.
- Soil permeability refers to the ability of soil to allow air and water movement through the soil. Soil texture, structure, and organic matter all contribute to permeability. Soils that are least subject to erosion from rainfall and sheet flow runoff are deep soils with high permeability rates. Permeable soils reduce runoff. Surface texture affects how soils erode. Textured surfaces with ridges and dimples slow runoff. The small low spots hold pockets of water facilitating infiltration. Textured soils have a greater surface area than smooth soils providing a more ground to be wetted before runoff begins. Compaction diminishes permeability and increases runoff and smooth surfaces allow runoff to flow quickly.

2.1.2.3 Topography

Topographic features strongly influence erosion potential. Watershed size and shape affect runoff rates and volumes. Swales and channels concentrate surface flow, which results in higher velocities and greater erosion potential. Slope length and slope steepness are critical factors in erosion potential, since they contribute to the velocity of runoff. Long, steep and continuous

slopes allow runoff to add volume and, increase velocity over distance. High velocity runoff can produce rills and gullies.

The location on a slope also has a major bearing on erosion potential. The base of a slope is more susceptible to erosion than the top. The top of a slope receives only the water that lands as rainfall directly on it. The bottom of a slope receives rainfall plus the accumulated runoff from the slope above.

2.1.2.4 Ground Cover

The term ground cover refers principally to vegetation. Vegetation is the most effective means of stabilizing soils and controlling erosion as a permanent erosion control measure. Other ground covers prevent splash erosion, retain moisture, promote infiltration and prevent erosion. Other ground covers include mulches, matting, straw, plastic sheeting, wood chips, compost and crushed rock.

2.2 Impacts of Erosion and Sedimentation

2.2.1 Environmental Impacts

Many environmental impacts from sediment pollution are cumulative and the ultimate results and costs may not be evident until years later. Waters adjacent to ODOT managed lands contain fish that are federally listed endangered species. The listings increase the scrutiny of our projects by regulatory agencies. More significant, pollution's impact on endangered species can have unfortunate and permanent consequences. ODOT's responsible stewardship of its lands is important.

- Eroded soil contains nitrogen, phosphorus, and other nutrients. When carried into water bodies, these [nutrients](#) trigger several negative consequences.
- Erosion of streambanks and adjacent areas destroys streamside vegetation that provides cooling shade and contributes to high quality aquatic and wildlife habitats.
- Down cut stream channels can lower water tables of surrounding floodplain to a depth below the root zones of native plants.
- Sediment deposited in streams can cover fish spawning gravels, eliminating habitat or smothering developing eggs.
- Sediments in streams can smother the bottom fauna, affecting the food web.
- Turbidity from sediment reduces in-stream photosynthesis, which leads to reduced food supply and habitat.
- Turbidity increases the amount of sunlight absorbed in water, raising stream temperatures.
- Turbid water carries abrasive particles that can damage the thin membranes of fish gills with sub-lethal or lethal results.
- Turbid water decreases visibility making it more difficult for predatory species to locate prey.

- Warmed turbid water has a lower oxygen carrying capacity making it difficult for aquatic species to breathe.
- Erosion removes topsoil which is the biologically active strata of soil that best supports plant life.
- Erosion leaves scars of infertile mineral soil in the landscape. These have reduced aesthetic value and are slow to revegetate.



Woven coconut fiber matting (coir) with compacted coir "face" stabilizes stream bank soils. Embedded large wood deflects flows, slows velocity along shore margin and provides calmer micro-habitat for juvenile fish

Figure 2-5 Matting Product Provides Protection of Waterway from Erosion

2.2.2 Economic Impacts

Many economic impacts are hard to quantify. How can a dollar value be assigned to loss of aquatic habitat or poor aesthetics? Other impacts may be readily quantified: such as in a silted-up reservoir.

- Excessive sediment accumulation reduces reservoir storage capacity and more frequent sediment removal is required.
- The cost of building new reservoirs to replace lost reservoir capacity is high. Increasing land values and lack of available sites are making this alternative much less feasible.
- Nutrients carried in sediment can feed algal blooms which excrete toxins that are not easily removed from drinking water sources. Upgrading water quality facilities to treat these toxins is costly. Algal blooms in resort waters severely reduce tourism and recreation economies.
- Sediment deposited into streams reduces flow capacity, interferes with navigation, and increases the risks of flooding. Regular maintenance dredging is required.
- Erosion severely diminishes the ability of the soil to support plant growth; to restore this ability is costly.
- During construction, time spent cleaning up sediment and repairing and replacing neglected BMPs removes staff from construction activities and can affect schedule and budget.

- [Fines](#) for depositing sediment pollution can be significant and egregious violations can result in jail time.

2.2.3 Pollutants

This section covers potential impacts on natural systems associated with pollutants from construction activities, and provides an overview of important pollutant categories and some of their effects on the environment. Pollutants are substances that can render water harmful to people, fish, or wildlife or impair recreation or other beneficial uses. Sediments, nutrients, bacteria, organic chemicals are the most important classes of pollutants. Heavy metals, petroleum-hydrocarbons and synthetic organics are frequently classified as toxic pollutants, depending on their characteristics. Green concrete, wash water from concrete trucks or tools and stormwater runoff from cement amended soils is considered a pollutant. Regulatory agencies closely monitor all of these pollution sources. See [Chapter 1.2.3.1](#) and the [1200-CA Permit's Appendix A](#) regarding the Environmental Management Plan (EMP) which defines measures to control pollutants and prevent contaminants from leaving a project site in stormwater runoff.

2.2.3.1 Sediment

Sediments and other suspended solids are the most common pollutant in storm water runoff. Deposited sediments can affect adjacent properties and clog catch basins and storm drains, causing flooding and higher maintenance costs. Sedimentation interferes with recreational use and has environmental impacts as noted above. In addition, sediments can transport many other pollutants, including nutrients, bacteria, metals and some organic pollutants. The prevention of sediment pollution is the primary focus of erosion and sediment control plans. Sediment discharge is conspicuous, it displays poor project “housekeeping” and it results in complaints from the public.



Figure 2-6 Sediment Non-Compliance

2.2.3.2 Nutrient

Plants require nutrients, such as phosphorus and nitrogen for growth, but nutrients in receiving waters can harm water quality. Excess nutrient levels over-stimulate the growth of algae and other aquatic plants, potentially causing unpleasant tastes, odors, unsightly conditions and lowered dissolved oxygen levels from plant decay. Algae blooms, like blue-green algae, can result in the presence toxins in the water that are severe enough to kill aquatic life, disrupt drinking water supplies or cause prohibitions of water contact. Nutrients tend to be more of a problem in slow moving water such as lakes or sluggish streams. Sources of nutrients include organic and inorganic fertilizers, soils and decomposing vegetation.

2.2.3.3 Concrete

Wet concrete is highly alkaline and can be caustic and corrosive. If the slurry from washing concrete from tools or from the hoppers and chutes of trucks enters waterways, it can harm fish gills and eyes and interfere with reproduction. Concrete wash water can percolate through the soil and diminish pore space, alter the soil chemistry, inhibit plant growth and contaminating ground water.

2.2.3.4 Bacteria

The presence of disease-bearing organisms in surface waters, such as bacteria and viruses, potentially threatens public health. The presence of fecal coliforms indicates that warm-blooded animal waste is present. The most common impacts associated with fecal coliform pollution is reduced recreational opportunity. Potential construction site sources of fecal coliforms include outhouses that are not maintained or pumped out on a regular basis. The clearing and grading process can also expose waste, deposited prior to construction, to runoff.

Bacterial decomposition of plant, animal and chemical wastes requires oxygen. When this process occurs in water, it reduces the oxygen available for fish and other aquatic organisms. If dissolved oxygen levels become too low, fish and other aquatic organisms may become stressed or die. Construction sites can be a source of oxygen-demanding substances. Cleared vegetation, exposed soils, spilled chemicals, and animal or human wastes can all contribute to lower oxygen levels in water.

2.2.3.5 Heavy Metals

Many metals are toxic and are regulated by the Environmental Protection Agency (EPA). Specifically, EPA classifies eight metals (arsenic, barium, cadmium, chromium, lead, mercury, selenium and silver) as hazardous and regulates their disposal.

Metals such as copper and zinc, which partially dissolve in water, may create toxic conditions for fish and other aquatic life. Metals in construction site runoff attach to sediments. Sediments carrying heavy metals often settle out from water and accumulate on stream and lake bottoms where they can remain for a long time. The metals accumulate in the tissue of organisms,

which are then eaten by predators near the top of food chains. High concentrations of heavy metals can be found in these predators.

Construction materials or equipment that contain such metals include paints, preservatives, metal downspouts, brake linings and tires. Other metal sources are wastes such as used automotive liquids, fuels, dust from sanding or grinding metal and painted surfaces, and wash from roadways.

2.2.3.6 Petroleum Hydrocarbons

Petroleum hydrocarbons include crude oil and any products derived from it, such as gasoline, diesel fuel, solvents, mold release compounds and lubricating oils. Petroleum products can be present in a number of forms on a construction site. If released to the environment, they can harm water quality. Certain petroleum products are acutely toxic and can kill fish and invertebrate life. Petroleum products also consume oxygen as they decay naturally and greatly reduce the aesthetic qualities of aquatic environments. As a result of these potentially severe impacts, petroleum products require special care during storage, transfer, and usage on construction sites.

Petroleum residue accumulates on paved roads from leaks in vehicles. Considering the negative impacts to the environment caused by petroleum products ODOT is required to treat stormwater runoff from pavement to remove those pollutants from the water. There are a number of mechanisms that do this, but the ones that affect erosion and sediment control use special soils and vegetation to address the issue. Dense vegetation, like a thick growth of grass will physically intercept and hold water borne oils. Microbes in soil can consume and break down petroleum products, providing another means of treating polluting runoff. Used in tandem these two mechanisms provide the treatment that is required.

There are five basic types of treatment: water quality structures, stormwater control ponds, water quality biofiltration swales, water quality bioslope and water quality filter strip. Although all of these require erosion and sediment control BMPs, the biofiltration swales, water quality bioslope and water quality filter strip present unique risks. These features deal with flowing water and rely on vegetation for permanent stabilization. It is common that stormwater runoff is directed to these features before the vegetation is established. Matting that is resistant to flowing water and temporary check dams to slow the velocity of water are necessary to protect the water quality facility while vegetation is establishing. It is



Figure 2-7 Erosion control failure at water quality facility

important that designers and project managers know that permanent erosion and sediment control features may conflict with the standard procedures used by Maintenance to keep these water quality facilities functioning effectively.

2.2.3.7 Synthetic Organics

Synthetic organic substances include most pesticides, preservatives, solvents, and plasticizers, as well as incidental and unwanted by-products of fuel combustion. Many organics, depending on their composition, are slow to degrade and remain in the environment for long periods of time. Synthetic organics can be toxic to fish and other aquatic life and are sometimes classified as carcinogenic (cancer causing).

Organics can be liquid or solid products, or waste materials. Liquid and solid products may enter the environment when they leak or are spilled from containers during use, are carried away by rain water and wash water, or are spilled or dumped on the ground or down the storm drain. Therefore, they also warrant a special consideration for careful inspection at construction sites.

Table 2-1 Overview of Pollutant sources, impacts, and indicators

POLLUTANTS	MAJOR SOURCES	IMPACTS	INDICATORS
Sediments and other solids	Clearing/grading; Exposed soils	Cloudy water; smothering of fish eggs and insects; flooding	Total suspended solids; turbidity
Nutrients	Cleared vegetation; exposed soils; human/animal	Algal blooms; reduced oxygen; aquatic plant	Different forms of phosphorus and nitrogen
Bacteria	Human/animal wastes; sewer lines; septic tanks	Shellfish contamination; human health effects	Fecal coliforms
Oxygen demanding materials	Cleared vegetation; human/animal waste; chemical reactions	Reduce oxygen in water, stress/kill salmonid fish and other aquatic life	Biological Oxygen Demand (BOD); Chemical Oxygen Demand (COD); dissolved oxygen
Heavy metals	Paints, flashings, downspouts, tires, preservatives, solvents	Bioaccumulation in food chain; toxic to aquatic life, human health effects	Ar, Cd, Cu, Hg, Ni, Pb, Zn
Petroleum hydrocarbons	Oil, grease, fuels, lubricants	Decreased oxygen levels; aesthetics, human, aquatic and wildlife health effects	Oil & grease; total petroleum hydrocarbons

POLLUTANTS	MAJOR SOURCES	IMPACTS	INDICATORS
Synthetic organics	Pesticides, PCBs, combustion products, solvents	Bioaccumulation in food chain; toxic to aquatic life, wildlife and humans	Variety of organics analyses
Concrete	Spills, truck washout, overfull washout basins	Harm to aquatic species, stunted plant growth, ground water pollution	Concrete slurry, Hardened concrete crust surrounding washout

2.3 Principles of Erosion and Sediment Control

Effective erosion and sedimentation control requires first that the soil surface be protected from the erosive forces to prevent erosion, and second that eroded sediment is captured on-site. Erosion control is the prevention of soil erosion. Sediment control is the trapping of suspended soil particles. Erosion control is easier than controlling sedimentation. Sediment control is necessary because some erosion is unavoidable. The following principles are simple but are effective. They should be integrated into a system of control measures and management techniques to control erosion and prevent off-site sedimentation.

- Fit site construction to the terrain. Review and consider all existing conditions in the initial site selection for the project. When construction is tailored to the natural contours of the land, little grading is necessary and erosion potential is consequently reduced.
- Time grading and construction to minimize soil exposure. Scheduling can be a very effective means of reducing the hazards of erosion. Stage construction activities to minimize the exposed area and the duration of exposure. In scheduling, take into account the season and the weather forecast. Schedule grading to coincide with a dry season. Stabilize disturbed areas as quickly as possible and if possible suspend work during wet season. The Specifications require that additional measures be employed to during the wet season to prevent erosion and sedimentation.



Figure 2-8 No erosion, stable channel & clear water

- **Retain existing vegetation whenever feasible.** Vegetative cover is an effective form of erosion control; very little erosion occurs on a soil covered with undisturbed natural vegetation. If possible, clear only the area where construction will actually occur, street and driveway lines, and cut and fill slopes. Try to integrate existing trees and other natural vegetation into the site improvement plan.

- **Protect and preserve buffer zones.** The 1200-CA Permit states that a 50' band of undisturbed vegetation is required between project work and water bodies. See the Permit's [Appendix B](#) for guidance on buffer zones.

- **Vegetate and mulch denuded areas.** Newly planted vegetation begins to duplicate the functions of established vegetation. Seed and mulch denuded soils as soon as possible after grading is completed. Mulch helps seedlings to become established and protects the soil from raindrop splash until vegetation takes over.



Figure 2-9 Compost blankets provides erosion prevention

Soils may be seeded with temporary or permanent vegetation. If the soil will be exposed during the winter months, protective measures other than vegetation must be used.

- **Divert runoff away from denuded areas.** Manage and control runoff in areas that have been denuded. Route runoff into stabilized channels. Divert runoff from off-site around the work areas using temporary piping, diversion dikes or swales. For conveying runoff down steep slopes temporary slope drains or protected flumes should be used with energy dissipaters at the bottom of the slope. The runoff containing sediment should be directed to Baker Tanks, sediment traps or settling basin if turbid flows are anticipated.



Figure 2-10 Seeded perennial rye grass with wattles to shorten slope length

- **Cover exposed soils.** Matting in the form of rolled erosion control products (RECPs), mulch, compost blankets or hydraulically applied matting will protect soils and provide immediate protection that does not rely on seed germination and plant establishment to provide cover.
- **Minimize length and steepness of slopes.** Slope length and steepness are among the most critical factors in determining erosion risk. Increasing slope length and steepness increase the velocity of runoff, which increases erosive energy. If slope steepness is doubled while other factors are held constant, soil loss potential is increased 2 ½ times. If both slope steepness and length are doubled, soil loss potential is nearly 4 times greater. To prevent erosive velocities from occurring on long, steep slopes, interrupt the slopes at regular intervals using sediment barriers, terracing or other means.

- **Keep runoff velocities low.** The energy of flowing water increases at the square of the velocity. For example, when the velocity doubles; the erosive force quadruples and the water can theoretically move particles 64 times larger by volume. Channel velocities can be kept low by lining drainage ways with rough surfaces such as vegetation and riprap, by designing broad, shallow flow areas, and by constructing check dams at frequent intervals. Concrete channels, although efficient and easy to maintain, convey runoff quickly, often resulting in downstream channel erosion and flooding.



Figure 2-11 Check Dams slow runoff velocity

- **Prepare drainage ways and outlets to handle concentrated or increased runoff.** Construction changes the characteristics of runoff. The creation of impervious surfaces, removal of plant cover, and compaction of soil allows less water to infiltrate into the soil and therefore increases the volume of runoff. Drainage channels should be designed to provide maintenance access for the removal of accumulated sediments. Alternatively, if a project can be designed so that runoff from development areas is allowed to infiltrate into the soil on-site, no off-site channel enlargement or protection should be

necessary. To prevent channel erosion from occurring, design drainage ways to withstand the peak flows without erosion, select lining materials appropriate for peak flows, and de-energize concentrated flows at outlets using scour holes and energy dissipaters. If development substantially changes the natural drainage conditions in a watershed, merely protecting the drainage channels on a project site may not be sufficient to prevent erosion.



Figure 2-12 Stabilized Channel

- **Trap sediment on site.** Some erosion during construction is unavoidable. The function of a sediment barrier is to prevent sediment from leaving the Project site. Sediment laden runoff should be detained on-site so that the soil particles can settle out before the runoff enters receiving waters. Locate sediment basins and traps at low points below disturbed areas. Use earth dikes or swales to route drainage from disturbed areas into the basins. Sediment barriers and sediment fences can be placed below small-disturbed areas on gentle to moderate slopes. Storm water temporarily ponds up behind these barriers, allowing sediment to settle out.



Figure 2-13 Sediment Trap & Energy Dissipater W/ Level Spreader

Sediment traps are required by the 1200-CA permit to either hold runoff from a 2 year/24 hour storm or 3,600 cubic feet of storage. Smaller sediment traps may be used in combination with other BMPs. **ESCP sheets that with sediment traps must be stamped and signed by a licensed engineer.**

- **Inspect and maintain control measures.** Inspection and maintenance of control measures are vital to the effective function of an erosion and sediment control facilities

and they are required by both the specifications and the permit. Most control measures require regular maintenance. Problems often occur during the first storm of the season. Some problems, like rills, develop slowly over time and can easily be prevented with inspection and maintenance. Effective functioning of each BMP is required by the permit and the Specifications. The permit requires the contractor inspect active sites weekly and within 24 hours of a storm event of one half inch or more. Correct problems as soon as they develop. Specification Section 00280.30 requires the Contractor assign an individual, knowledgeable in erosion and sediment control, to be responsible for routine inspections of operating erosion and sedimentation control practices. As project permittee, ODOT is ultimately responsible for compliance with permit requirements, including the inspections and monitoring reports.

- **Take Erosion and Sediment Control work seriously.** Erosion and Sediment Control is contracted work for which the Contractor is being paid. The Erosion and Sediment Control work is required in the permit conditions which are enforceable by law and punishable by severe penalties. This work should be conducted and managed with the same level of professionalism and oversight as is provided for other aspects of contracted work.

The principles of erosion and sediment control discussed above generally address issues that operates on the soil's surface. There are engineering practices that work on a larger scale of slope protection. The following practices are the domain of engineers and geotechnical engineers, but their use will improve erosion control results.

- **Slope Rounding and Contour Grading.**

The standard practice of rectilinear grading creates unnatural flat slopes, sharp angles and rapid runoff flow that resists infiltration.

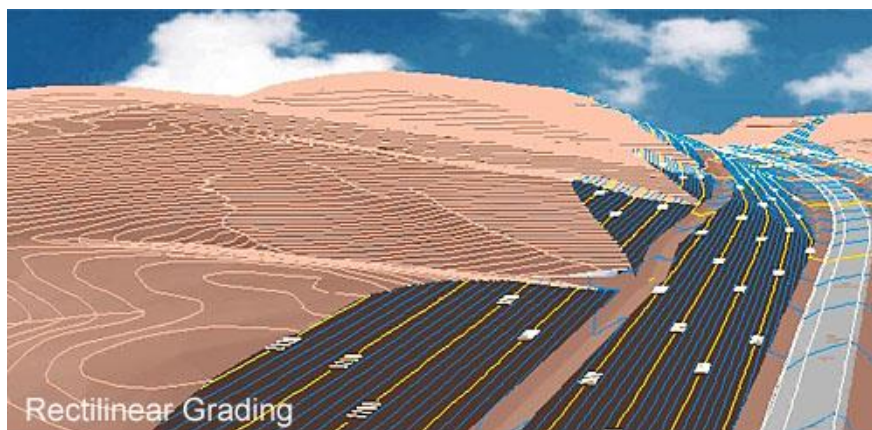
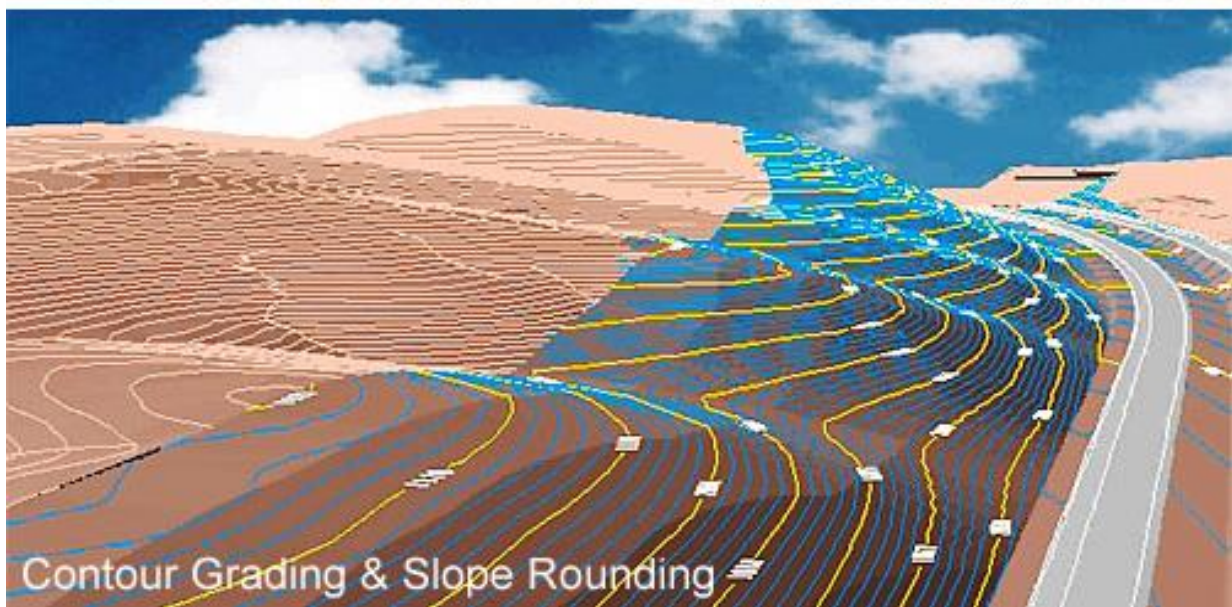


Figure 2-14 Rectilinear Grading



Contour Grading & Slope Rounding

Contour grading with slope rounding results in natural landform shapes that break the slopes into smaller watersheds with runoff flow patterns that are more resistant to erosion. (photos courtesy of CalTrans)

Figure 2-15 Contour grading with slope rounding

- Stepped Slope:

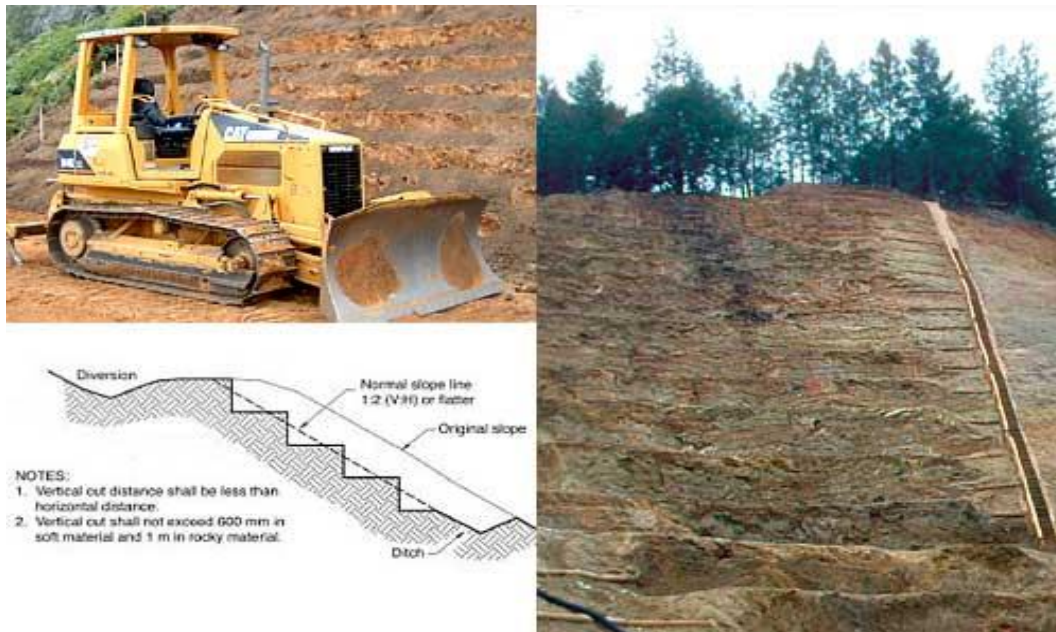


Figure 2-16 Stepped Slope

Constructing cut slopes that are terraced or stair-stepped slow stormwater runoff. Slowed water can infiltrate at each terrace. Material that is eroded off the surface will accumulate on each terrace providing seed bed material for vegetation to provide permanent erosion control. Cut slopes not stabilized by vegetation will travel and erode in perpetuity and be an enduring source of maintenance tasks.

- Layer geogrid into embankment slopes:



Constructing embankment layered with reinforcing geogrid will prevent the mass landslide known as the deep rotational slump.

Figure 2-17 Geogrid

- Dewater the hillslope:



Water adds weight and lubrication to the structure of slopes that can result in landslides. Removing that water helps stabilize slopes especially in landslide prone locations. Horizontal drains (shown) can be drilled into hillsides. Drain boards can be layered into the construction of embankment slopes to help water exit those structures.

Figure 2-18 Horizontal Drains

Chapter 3 - EROSION AND SEDIMENT CONTROL MEASURES AND BMP'S

3.1 Erosion Prevention and Sediment Control

This chapter presents Best Management Practices (BMPs) for erosion and sediment control. The discussion for each BMP includes typical applications and design criteria. Additional information such as the advantages, disadvantages, maintenance requirements and common failures of each BMP are also included, and should help the designer to choose the most appropriate measure or control and to develop special provisions.

The best current thinking continuously evolves and new products to address erosion prevention and sediment control are constantly being introduced into the marketplace. The Agency strives to keep this manual updated to provide good and current information. Erosion control designers, contractors and project managers do well to keep apprised of new developments in erosion and sediment control products and technology.

The details of installation can and should vary in the field depending on the site conditions. Field variations for each type of BMP are encouraged. The substitution of other cost-effective products or methods that provide substantially equivalent or superior performance is allowed if approved by the Agency.

As implied by their name, Best Management Practices - BMP's are planning strategies, stabilization methods and structural erosion control measures that represent the best commonly accepted practices. Table 3-1 presents ratings for basic applications of commonly used erosion control measures.

ODOT has developed a suite of [Standard Drawings](#) that provide graphic examples of how BMPs are correctly used. These Standard Drawings, and the similar Standard Details are developed for all of the most commonly used products and practices and they are provided in this document in Appendix C. When noted as reference in Project Plans the standard drawings or details become contract documents that provide the correct and required method of installation or use of the BMP.

Table 3-1 Matrix of temporary and permanent erosion control measures and estimated effectiveness

Ratings: E = Excellent, M = Moderate, P = Poor

BEST MANAGEMENT PRACTICE	TEMPORARY VS PERMANENT	RATING	PAGE
Erosion Prevention			

BEST MANAGEMENT PRACTICE	TEMPORARY VS PERMANENT	RATING	PAGE
Preserve Natural Vegetation	P	E	3-44
Buffer Zone	P	E	3-46
Seeding	T/P	E	3-48
Mulch	T/P	E	3-60
Sod	T/P	M	3-67
Matting	T/P	E	3-70
Compost Blanket	T/P	E	3-75
Plastic sheeting	T	P	3-78
Dust Control	T	M	3-80
Fiber Rolls (Wattles)	T/P	M	3-116
Compost Sock	T	E	3-118
Chemical Soil Stabilizer	T	M	3-80
Haul Road Stabilization	T	E	3-111
Check Dam	T	M	3-93
Runoff Control			
Slope Drain	T	E	3-84
Outlet Protection	T/P	E	3-88
Surface Roughening	P	E	3-90
Check Dam	T/P	M	3-93
Diversion Dikes and Swales	T	M	3-97
Sediment Control			
Construction Entrance	T	E	3-105
Tire Wash Facility	T	E	3-108
Road/Parking Stabilization	T	E	3-111
Biofilter Bags	T	M	3-114
Fiber Rolls (Wattles)	T	M	3-116
Compost Sock	T	E	3-118
Compost Berm	T/P	M	3-121
Wood Chip Berm	T/P	M	3-121
Check Dam	T/P	M	3-93
Sand Bags	T	M	3-123
Brush Barrier	T	M	3-125
Filter Berm	T	M	3-126
Pre-fabricated Barrier System	T	M	3-128
Sediment Fence	T	M	3-131
Inlet Protection	T	M	3-135

BEST MANAGEMENT PRACTICE	TEMPORARY VS PERMANENT	RATING	PAGE
Sediment Trap	T	E	3-141
Flocculent Treatment	T	E	3-145
Temporary Settling Tanks	T	E	3-146

3.2 Erosion Prevention

Erosion prevention is the most effective and inexpensive method for reducing sediment pollution. 1/2 inch of rain over one acre has a volume of 67 cubic yards. The idea of removing sediment from that volume highlights why erosion control is more effective than removing sediment from turbid water. Limiting the amount of exposed soil, covering soil, controlling surface water runoff, shortening slope length and checking runoff velocity are ways to minimize erosion during construction. Permanent erosion control usually consists of stabilizing exposed soils with permanent vegetation. Prior to permanent stabilization temporary stabilization is required. Reducing the erosion associated with construction vehicular traffic is also covered in this section. Many of these techniques can reduce erosion by 80 to 95 percent compared with exposed soils.

3.2.1 Erosion Prevention Best Management Practices

1. Preserve Natural Vegetation
2. Buffer Zone between work and resource
3. Temporary and Permanent Seeding
4. Hydraulically Applied Matting
5. Straw or Wood Chip Mulch
6. Compost Mulch
7. Sod
8. Matting
9. Plastic Sheeting
10. Shorten Slope Length
11. Check Dams
12. Haul Road Stabilization
13. Dust Control

3.2.1.1 Preserve Natural Vegetation

This BMP involves preserving natural vegetation to the greatest extent possible during the construction process and after construction where appropriate. Maintaining natural vegetation is the most inexpensive form of erosion prevention control. This method is particularly important in sensitive areas such as wetlands, stream corridors, lakes, and near steep slopes. The project

manager, inspector and contractor should address and discuss preserving natural vegetation during the Pre-Construction Conference.

3.2.1.1.1 Applications

- All areas where it is practicable, especially flood plains, wetlands, stream banks, steep slopes and other areas where erosion controls would be difficult to install and maintain.

3.2.1.1.2 Advantages

- Helps reduce soil erosion and runoff while retaining the aesthetics of an area.
- Existing vegetation is installed and paid for. This saves erosion control costs and revegetation costs
- Existing vegetation provides areas for wildlife, and provides visual screening.
- Helps maintain cooler water temperature. Temperature moderation is especially important when associated with fish-bearing waters.
- Retains existing shade and cover habitat.
- Reduces issues with Migratory Bird Treaty Act.

3.2.1.1.3 Disadvantages

- Retaining older trees could create a safety hazard.
- May constrict area available for construction activities.

3.2.1.1.4 Special Considerations

- Requires coordination with environmental professionals such as landscape architect and the construction Project Manager's office.
- Requires the Contractor to fence or flag the clearing limits or tree and shrub protection zones
- Tree removal must occur when not active nesting is occurring to comply with the Migratory Bird Treaty Act.
- Retained vegetation may require alterations to future maintenance activities.
- If possible, work with the contractor to establish a phased clearing and grading schedule at the beginning of the project.

3.2.1.1.5 Design Criteria

- Coordinate with the Landscape Architect and Environmental Professionals assigned to the project when determining what to save and how to save it.
- Vegetation can be preserved in natural clumps or as individual trees, shrubs and vines.
- Clearly flag or mark the ground disturbance limits outside the dripline of preserved trees.
- Protect vegetation from:
 - Construction equipment injury above or below the ground level. Injury occurs from scarring, cutting roots, or soil compaction.
 - Compaction: do not allow vehicle passage, parking, material storage or stockpiling within vegetation protection zone.

- Grade changes, which affect the plants' root zone. Excavation should smoothly transition to existing grade no closer than at tree's drip line. Embankment around trees can be accommodated by placing a layer of round drain rock or open graded aggregate and a tile system over the roots before placing fill to allow air to circulate to root zone. Place no soil over root crown or on trunk of trees. Consult arborist when planning embankment around existing trees.
- In excavation, terracing the area around the plant, or leaving the plants on an undisturbed mound can increase the plants' survival chances.
 - Root exposure can negatively affect vegetation.
 - Change in established hydrology can negatively affect vegetation.
 - Root damage caused by trenching for drainage lines, water and sewer lines or electrical service.

3.2.1.1.6 Maintenance

- Inspect and repair flagging or fencing.
- Re-cover exposed plant roots.

3.2.1.1.7 Common Failures

The most common problems with this BMP are:

- Non-observance of clearing limits and clearing of the entire site prior to construction
- Poorly executed or ill-considered tree protection can result in vegetation dying.

3.2.1.2 Buffer Zone

A buffer zone consists of an undisturbed area or strip of established vegetation adjacent to a disturbed area that reduces erosion, captures sediment and slows runoff. Permits or local ordinances may require buffer zones.

3.2.1.2.1 Applications

- Between disturbed areas and streams, other water bodies or wetlands.
- Between natural swales and wetlands.
- 1200-CA permit requires 50' buffer zone or protection equivalent to a 50' buffer zone.
- Work adjacent to Total Maximum Daily Load (TMDL) listed waters require a 50' buffer zone plus additional 25' of buffer zone for every 5 degrees of slope between work and water.

3.2.1.2.2 Advantages

- Filters Sediment.
- Promotes infiltration.
- Provides riparian habitat.
- Provides cooling shade to water.
- Reduces velocity and quantity of runoff, dissipates energy.

- Provides visual screening.
- Can be used to stabilize stream banks.
- Low maintenance.

3.2.1.2.3 Disadvantages

- Requires keeping all construction equipment, debris and soils out of the natural areas.
- Extensive buffers can cover large areas of land that are not available for project development.

3.2.1.2.4 Special Considerations

- Constrains work area and equipment movement.
- Requires the Inspector or Contractor to fence or flag the clearing limits.
- Requires the Inspector or Contractor to fence or flag outside tree and shrub driplines.
- If possible, work with the contractor to establish a phased grading plan that includes buffer zones.
- Where required width of buffer is not available, BMPs must be provided that provide equivalent protection as required buffer.

3.2.1.2.5 Design Criteria

- Preserve natural vegetation 50' band parallel to Ordinary High Water line.
- Preserve natural vegetation on unstable, steep slopes.
- Vegetative buffer zones for streams, lakes or other waterways are required to be 50' in width. Buffer zone effectiveness is improved as width increases, so buffer zones should be as wide as is practicable between ground disturbance and the water.
- Where limited right of way or other constraints prevent the preservation of buffer zones, additional BMPs are required to provide protection equivalent to the undisturbed vegetation. The 1200-CA Permit's [Appendix B](#) provides formulas to determine the equivalent level of protection.

3.2.1.2.6 Maintenance

- Inspect flagging and fencing frequently and repair as needed.

3.2.1.2.7 Common Failures

The most common problem with this BMP is non-observance of buffer zone delineation and disturbance of regulated area.

3.2.1.3 Seeding

A well-established vegetative cover is one of the most effective methods of preventing erosion. The most effective practice is to establish vegetation on most construction sites as the slopes are finished, rather than waiting until all the grading is complete. This and other requirements are described in Section 01030 of the [Oregon Standard Specifications For Construction](#). It is often the case that the seeding provided to the project will be the final treatment for roadsides. Beside erosion

control, this treatment will be the aesthetic finish and the environmental piece that ties the project to the context of the location. It is worth doing well. The [Roadside Development Manual](#) goes into depth regarding seeding. Within the Manual there is guidance and several resources to assist in decision making regarding seeding.

3.2.1.3.1 Applications

- On disturbed areas that require seeding either because the area has reached final grade (permanent seeding) or because the area will remain undisturbed for over 2 months (temporary seeding). Refer to Section 01030.43, or [Chapter 6](#) of this manual for soil exposure limitations and seeding dates.
- Stockpiles
- Reclaimed access/haul roads and staging areas
- In vegetation-lined channels, seed and then protect with matting.
- In retention/detention ponds.

3.2.1.3.2 Advantages

- Prevents erosion and also traps sediment.
- Promotes infiltration.
- Improves appearance of the site.
- Reduces runoff.
- Provides excellent stabilization.
- Relatively inexpensive erosion control measure.

3.2.1.3.3 Disadvantages

- Needs sufficient time for seed to establish.
- Requires mulch or other cover to keep soil/seeds in place during seed germination and establishment.
- Compacted surfaces require ripping or tilling to break up compacted soil for site prep.
- May require soil conditioners, amendments and/or bio-amendments on poor soils.
- May require irrigation.
- Must be removed prior to applying fill material.

3.2.1.3.4 Design and Selection Criteria

Because of the variety of climates, elevations and eco-regions in Oregon no single standard seed mix is appropriate. Because the plants that result from erosion control seeding remain long after construction is done and risk of erosion is abated, the designers should know the species origin of and characteristics of the plants they are seeding. Seed mixes should be designed for the climate and conditions of the project site. A seeding designer should be familiar with the characteristics of the plants being seeded. When erosion control seeding is used for permanent seeding, issues of concern are:

- What is the soil type and condition? Haul road or site access routes will require loosening of the surface soils to eliminate compaction.

- Soils on cut slopes require loosening along contour as described in 01040.48(d).
- Soil surfaces are to be textured by “track walking” as described in Section 00280.43. (this is not for the purposes of compaction)
- Is the seeded plant low growing and low maintenance?
- Is an annual or perennial, deep or shallow rooted?
- Does the seed need cold stratification or other treatment to germinate?
- Does it germinate in spring or whenever it is watered?
- Is it forage or cover for large wildlife that are not desirable adjacent to roadways.
- Is it a noxious weed or otherwise aggressive, dominant, invasive, toxic or otherwise inappropriate?
- Does the seeding need to satisfy other goals such as treating stormwater runoff, provide pollinator habitat, restoring a native plant community or provide a showy floral display?
- Does the site have a regulatory requirement of native plant cover?

Furthermore ODOT’s goal of being a responsible environmental steward requires that thoughtful consideration be given to the use of native grass and plant seeds when developing seed mixes.

Seed mixes are either temporary or permanent.

Temporary seeding is appropriate for areas that are planned for future disturbance. Temporary seeding is often rye grass that is fast growing and inexpensive. Although it quickly develops a thick green carpet of top growth, initially, the roots are neither deep nor strong. Rye grass is not a native grass. With its aggressive growth habits, rye grass can out-compete native plants for sunlight, water and nutrients and because it persists after introduction many experts consider it undesirable as the permanent ground cover.

Frequently a permanent seed mix is used as the temporary, erosion control seeding. This dual use is accommodated with the inclusion of a sterile, short lived “nurse crop” to provide quick cover. When other erosion prevention is provided the nurse crop is not necessary. Sometimes the temporary seed mix will consist exclusively of one of the nurse crop species.

Some nurse crop species are the sterile wheat grasses “Regreen©” or “Quickguard©”. These are agriculturally produced and

This photo shows the grain, cereal rye. This was seeded without approval. It grows tall enough to hide wildlife or obscure sight lines, it releases chemicals that inhibit the growth of other plants and it is a listed weed in Washington State.



Figure 3-1 Cereal Rye

copyrighted varieties. During years of large or multiple wild fires or other natural disasters, these patented erosion control grasses may be sold out and unavailable. Another fast germinating grass that does not persist in the landscape is “Poco” barley. This is a short growing grain barley

that dies out after a few years. These 3 nurse crop species have coarse top growth and large seeds. Noting the large seed size is important as a greater weight of seeds is needed to achieve a desired seeds per square foot. Some grasses are listed weeds or have growth habits that make them undesirable. Prior to seeding, verify that the specified seeds are what is being used. Accept no substitutions for specified seed mixes without written approval from the professional of record.

There are Oregon native grasses that have characteristics desirable in erosion control seeding. Two are small fescue (*Vulpia microstachys*) and slender wheatgrass (*Elymus trachycaulus*). Both germinate quickly and display vigor in growth. The small fescue is a low growing grass that can persist in the landscape. The slender wheatgrass is an annual grass that tends to diminish in the landscape over time. Always verify seed availability prior to specifying. Select species that are adapted to the climate in the Project area.

A few decades ago the standard for permanent seeding was a simple blend of grass species, usually nonnative, selected to be self-sustaining and provide soil cover. The few, simple requirements for roadside seeding did not consider a project's environmental context or take advantage of site opportunities. In the best current thinking, permanent seeding would consist of a mix of native grass, legume and forb seeds. This is consistent with ODOT's vision of being a responsible steward of State lands. Native species are suited to the climate and

conditions of the region. Native species also have evolved with insects, birds and animals that depend on them for food and habitat, and these plants depend on the animals for pollination and distribution of seeds. Including legumes in a seed mix enables these plants to fix nitrogen, a natural fertilizer, into the soil. Including forbs and wildflowers provides pollinator habitat and enlivens the roadsides with flowers. The use of native plant seeds should be approached with the foreknowledge that some native species germinate and establish slowly and may not provide vegetative cover in the 45 days required by the Specifications, hence the need for a nurse crop to be included in the mix and a protective mulch used with the seed application. A diversity of native seeds should result in a plant community that is stable, self-sustaining and that provides long term soil stabilization.

There is no requirement that native seed be used on projects. In many areas exotic plants/grasses already dominate the plant communities. In some agricultural areas some native grasses are undesirable due to the possibility that they could corrupt pure stands of an agricultural crop. The design intent of a project may require that a homogenous stand of turf grass be developed. Each project is different and different design styles are valid. It is important for designers to know site conditions, including adjacent lands and know the plant characteristics of the species being seeded.



Figure 3-2 Spoils Pile

This spoils pile was seeded with a mix that included lupine, which is a native legume wildflower.

A well designed seed mix would have a few native grasses of different genus so that different rooting depths and growth habits would be provided. The inclusion of wildflowers is desirable and has multiple benefits including beautifying roadsides for travelers. Permanent seeding should include nurse crop species if means are not provided to stabilize the ground during the time it takes for germination and cover. Depending on the project, tree and/or shrub seeds may be included. Do not introduce tree species in the roadway Clear Zone (distance varies) and be aware of potential conflicts with sight lines and maintenance operations when designing permanent seed mixes.

Seed mixes for erosion control and permanent cover are developed by a consultant designer or landscape architect, the ODOT Geo/Environmental section or the erosion control designer of record. Seed mixes and seeding rates are provided in the project Special Provisions in the Section 01030.

Seedling vigor is an important plant characteristic for erosion control seeding to rapidly establishment thick top growth and a dense fibrous root system. Even the fastest growing seeds do not provide stabilization during germination, so other means of protecting the soil is necessary during germination. Seedling vigor is not the only criteria by which to select seeds. Vigor after germination may be indicative of aggressive plant growth through maturity which can out-compete other, desirable species. Some grasses such as rye grass develop dense top growth quickly but are slower to develop robust root systems. Some species that germinate early, like the weed, cheatgrass (*Bromus tectorum*), make resources unavailable to later germinating species.

Other characteristics that are important for erosion control are the methods by which the grass develops, grows and spreads. Grasses can be rhizomatous, where the plant sends out runners that start new growth; a bunch grass; or a sod-forming grass. Rooting depth is important and for erosion control purposes grasses are characterized as being deep, moderate or shallow rooting. Selection of seeds for a mixture of rooting depths provides optimum support for soils and best enables the removal of water by the roots at the various zones in the soil.

3.2.1.3.5 Seed Qualities and Characteristics

Seed is normally specified by Pure Live Seed (PLS). Pure live seed refers to the portion of a seed lot that is live seed of the desired kind. The purpose of measuring seed on a PLS basis is so that debris and dead seeds do not diminish the seeding application rate. Wildflowers seed may be field collected and not agriculturally produced and have characteristics that fit poorly into the PLS model. When this is the case, Special Provisions should identify the issue and modify the PLS requirement for that specie.

Seed mixes are specified with the quantity of each seed species determined first by number of seeds per area, usually by square foot. Knowing the number of seeds per pound allow the formulation to be converted to weight of pounds per acre. Sizes of seeds of different species vary widely so it is necessary to formulate seed mixes using the seeds-per-pound as primary to the

calculation. A simple spreadsheet seed mix calculator is shown in the Appendix and linked in the [Guidance Materials](#) of the Roadside Development section of the ODOT web page.

Seed furnished for a project must meet the labeling requirements of the Standard Specifications, Section 01030.13. They must meet the requirements of state and federal seed law which, among other things, spells out exact seed labeling requirements. (See [Oregon Revised Statute 633.520](#)). For a brief summary of typical information that must be on the seed label, see Construction [subsection 7.3.3](#).

The seed label must be dated and provide the purity, germination rate and other information on the tag must be backed by a seed lab analysis report. High quality seed germinates well, has a high purity percentage, and is free of chaff, noxious weeds or unintended species. The identity, purity and uniformity of the seed being used on projects must be maintained at all times by continuing to monitor seed delivered to the project for proper labeling.

Certified Seed is a special category of seed that are agriculturally produced named varieties. This program assures seed growers and the industry that a seed variety is true to its original type so the type can be successfully kept true when grown for production by seed growers. The Oregon Certified Seed program is administered by the Oregon Department of Agriculture and Oregon State University. A list of seed varieties that are currently certified can be found in the [Oregon Seed Certification Service Handbook](#). Certified seed may be derived from select native species, or hybrids crafted for desired characteristics. Certified seeds provide a high level of assurance that the seed will be free from weeds or unintended species.

Native seed may be divided into two major distinctions, they are: agriculturally-produced seed and collected seed. The definition of “native” can vary from national to local, so be sure the desired definition is being used. Oregon has a robust marketplace in native seeds and a wide variety of species are available. Some native seeds can be scarce and expensive so seed mix designers should always verify seed cost and availability prior to specifying. When specifying native seeds; identify the functions and values that are desired from that species. It may be bloom period, community association or other characteristics that are desired. Once the desired characteristics are identified then select species that satisfy the characteristics that are strong growers that are available in the marketplace and that are reasonably priced. For erosion control seeding and for permanent seeding, even with wildflowers, it is not an agency goal to vegetate roadsides with rare or expensive plant species.

3.2.1.3.6 Timing of Seeding

The timing windows for seeding are provided in the Specifications in Section 01030.43. These seeding windows are arrived upon because they occur when the growing season coincides with available moisture. Often projects continue construction right up until late in the seeding window. The last day of the seeding window in Western Oregon is October 31. If seeding is late, it may get too cold for seeds to germinate and provide cover by the 45 day establishment period. 45 days from October 31 is the middle of December, so it is easy to anticipate that it will be

necessary to stabilize the soil by means that do not rely upon germination. Similarly the spring seeding window west of the Cascades ends May 15th. At that time of year the weather may allow germination but not get too hot or dry to support plant growth. Regardless of when seeding is applied, soil stabilization is required

- Apply permanent seeding on areas to be left dormant for 1 year or more.
- Apply permanent seeding when no further disturbances are planned.
- Within the seeding window, seed immediately after seedbed preparation, while the soil is loose and moist.
- Seed before applying mulch according to Section 01030.48.
- When matting is specified, apply seed before matting.
- The approved dates for seeding are provided in Section 01030.43. Seeding outside the dates shown require written authorization from Agency.
- The best time to apply seed is early in the fall seeding window. The spring seeding window carries more risk as weather can turn hot and dry even prior to the close of that window. Irrigation may be required for areas establishing during the hot summer months.
- When approved with written authorization, seed applied during the winter may take several months to develop a dense ground cover due to cold temperatures. The application and maintenance of mulch is critical for winter seeding. Additional erosion control measures that do not rely on germination need to be applied to provide temporary stabilization.
- Apply temporary seeding to stabilize disturbed soils and slopes that are not at finished grade and which will be exposed for 2 months or longer before being disturbed again.

3.2.1.3.7 Site Preparation

- Site preparation methods for seeding and for planting are listed in Section 01040.48.
- Bring the seed bed to final grade, remove all rocks and debris, and smooth surface undulations larger than 2 inches.
- Divert concentrated flows away from the seeded area.
- For optimum seeding conditions salvage and stockpile topsoil until final grades are established. Then spread topsoil over new grades.
- Conduct soil test to determine pH and nutrient content and to determine types and amounts of fertilizer and soil amendments.

- Apply soil amendments as needed to satisfy the soil test result recommendations. Incorporate these amendments into the soil.
- Roughen the soil surface by harrowing, tracking, grooving and furrowing so ridges or indents are parallel to the slope contours. Avoid compacting soils. See Section 00280.43
- Remove deep compaction in areas such as haul roads or road bed under pavement-removal. Compacted soils should be ripped or tilled to a depth of 12".
- The seedbed should be firm but not compact. The top 1 to 2 inches of soil should be loose, moist and free of large clods and stones.
- If the seedbed has been idle long enough for the soil to become compact, the topsoil should be harrowed with a disk, spring tooth drag, spike tooth drag, or other equipment designed to condition the soil for seeding.
- The topsoil surface should be in reasonably close conformity to the lines, grades and cross sections shown on the construction plans.
- Consult a Geotechnical Engineer prior to placing topsoil on slopes 1:2 or steeper. Tackifier or physical means may be required to hold the material in place.
- A compost blanket of coarse or medium compost applied at a depth of 2" and applied with tackifier has been proven to adhere on slopes of 1:2, of providing a good seed bed and of providing erosion prevention that does not rely on germination.
- Herbicide use must be approved by Project PM prior to use.
- Seed bed must be weed free prior to seeding
- Pre-Emergent herbicides form as layer on the soil surface that prevent root penetration from seeds, but have no effect on existing vegetation.



Figure 3-3 Roughened Soil Surface

3.2.1.3.8 Seeding

- Apply seed as specified in Section 01030.
- Seed to soil contact is the key to good germination. Seeding after installation of matting or straw mulch inhibits seed to soil contact and should be avoided. Compost provides a good seed bed.
- Apply seed at the rates specified using calibrated seed spreaders, cyclone seeders, mechanical drills, compost blowers with calibrated seed injection or hydroseeder so the seed is applied uniformly on the site.

- Hydroseeding should be applied from two different directions so that surface irregularities do not prevent full coverage.
- Broadcast seed should be incorporated into the soil by raking or chain dragging, and then lightly tamped to provide good seed-soil contact.



Figure 3-4 Seeding & mulch applied with Hydroseeder

- Apply mulch and tackifier or matting, as specified, over the seeded areas.
- To prevent seed from being washed away, confirm installation of erosion prevention measures.
- When hydroseeding, a mulch or dye tracer is required as a visual application aid.
- On slopes steeper than 1:2, hydroseeding requires an increased rate of tackifier to be applied.
- For additional discussion of hydroseeding, refer to subsection 3.2.1.5 in this Chapter.

3.2.1.3.9 Fertilizer

Best practice is to use no more fertilizer than is necessary. Good soils should not need much if any fertilizer. Fertilizer application should be based on recommendations provided with soil test results.

- Use soil test results to determine the exact type and quantity of fertilizer needed to prevent the over-application of fertilizer.
- Apply fertilizer as specified in Section 01030.
- When seeding is applied with compost blanket use no fertilizer.
- Use low phosphorous fertilizer when work is near water bodies and wetlands.
- Use no fertilizer within 50' of water bodies (dependent on permit conditions).
- Slow-release fertilizers remain in place and continue to function after seeds have germinated and during growth.
- The use of select topsoil (01040.14(a)) or compost can reduce the need for fertilizer and improves the overall soil quality.

- Provide project-specific application rates in Specifications, Section 01030.

3.2.1.3.10 Soil Bio-Amendments

Soil bio-amendments are not fertilizers or mineral soil enhancements. Bio amendments are living spores and food for the soil micro-biology that is integral to vital soils and healthy plant growth.

- Soil bio-amendments are described in Section 01040.17.
- Bacterial Food Amendments help support vital soil biological activity
- Fungal Food Amendments aid the support of mycorrhizal fungus which in turn provides water and nutrients to plants
- Protozoa food amendments help support another soil biological activity
- Mycorrhizal inoculants introduce a fungus into disturbed soils that develops a symbiotic relationship with plants. Mycorrhizal inoculates are not necessary in established topsoils.
- Manufactured products are available that combine multiple bio-amendments and organic mulches. They are designed to be easily and quickly applied with hydroseeding equipment. These advertise as being equal in results to compost mulch. Although they are an improvement over a no bio-amendment treatment, comparison testing conducted by ODOT indicates that seeding on compost blankets provides superior results.
- Peat in bulk or used in some manufactured bio-amendment products is a resource mined from living wetlands. Depending on extraction method, it may not be a renewable resource.

3.2.1.3.11 Mulching

- Refer to Specification Sections 00280.44 for mulch installation requirements for erosion control.
- Refer Specification Sections 01030.15 for mulch materials associated with seeding and Specification Section 01030.48 for application requirements regarding mulch with seeding.
- Hydraulically applied matting such as bonded fiber matrix, when used for seeding, may have a specified application rate that results in a thickness of mulch up to 3/16 of an inch. These products can provide erosion protection during plant germination and establishment equal to rolled erosion control products.
- Refer to Specification Sections 01040.20 for mulch materials associated with planting and Specification Section 01040.53 for application requirements regarding mulch with planting.
- Refer to Section 3.2.1.4 of this Chapter.
- Straw mulch in loose conditions is preferred for temporary seeding during the wet season on slopes 1:2 or flatter.



Figure 3-5 Straw Mulch being blown on site

- Soil exposure limitations are described in Section 00280.42. Generally, exposed soils, not under active construction must be covered within 14 days and at least one day prior to anticipated rain events. Other limitations apply. Mulch may be required during the dry season if:
 - Vegetative cover is not expected to meet success criteria within the 45 day establishment period;
 - Work prevented seeding during the spring seeding window.
 - Temporary soil cover is required that does not rely on germination;
 - There is a water body or other sensitive area close to the disturbed area; or
 - Significant precipitation is anticipated before the grass will provide effective cover.
- Apply mulch on top of the seed or, in some situations as specified or approved, apply mulch with the seed during hydroseeding. The application rate of seed should be increased if seed and mulch are applied in a single application.

3.2.1.3.12 Compost Mulch

Compost mulch is highly regarded for seeding and erosion control as is discussed below in this manual's section 3.2.1.4. Application of compost blanket is specified in Section 00280.44(f). Seeding the by hydroseeding on top of an installed compost blanket as described in Specification Section 01030.48(b)(2) provides good results. Other means of seeding compost can be performed using a metered seed injector with the compost blower. When properly installed with tackifier, a compost blanket will adhere to cut slopes of 1V:2H which are often the most difficult areas on which to get vegetation established.

3.2.1.3.13 Compost

- Compost mulch shall conform to criteria shown in Section 03020.

- Construct compost blanket as shown in [Standard Detail DET6017](#)
- Coarse or medium compost are the only material textures permitted for erosion control. Blend tackifier with compost during installation. (Fine textured compost may be used as soil conditioner or as mulch with planting.)
- Install compost with tackifier at thickness of 2 inches as shown in standard detail DET6017.
- Applying compost too thick can bury seed too deep, or hold seed too far from soil.
- Applying compost too thick on slopes can result in material slipping off slope if it becomes saturated.
- Applying compost of too fine a texture on slopes can result in material not draining and slipping off slope if it becomes saturated.
- Apply compost on surfaces that have been roughened by track walking or loosened in shallow furrows similar method.
- Compost can be applied at any time to provide erosion prevention, and it will provide a good seed bed when the seeding window opens for seeding with hydroseeder.
- Compost can dry out more quickly than soil.

3.2.1.3.14 Maintenance

- Newly seeded areas need to be inspected frequently to ensure the grass is growing and area is kept weed free.
- If the seeded area is damaged due to runoff, additional storm water management measures may be needed. Repair erosion damaged areas and re-seed and mulch damaged areas.
- Spot seeding can be done on small areas to fill bare spots where grass did not grow properly.
- If spot seeding is ineffective, use an alternate method, such as sodding or matting.
- Re-seed and protect with mulch any areas affected by erosion. If the erosion is caused by concentrated runoff, fix the runoff problem and then re-seed and mulch the area.
- Contractor is responsible to provide the vegetation coverage specified in Section 01030.60.

3.2.1.3.15 Common Failures

The most common problems with seeding are failure of the seed to grow and for this there could be multiple reasons and they are:

- Failure to properly prepare the seed bed, such as loosening soils on cut slopes per 01040.48(d).
- Erosion of seedbed soils before plants becomes established because soils were not stabilized prior to germination.
- Seeding outside of the optimum growing season. Seeding late in either the spring or fall seeding window may result in poor seed growing conditions.
- Improper selection of seed, using the wrong seeding method for the site.
- Inadequate application of seed or insufficient coverage of mulch and tackifier.

- Substitution of seed variety without prior approval by the Agency
- Erosion of seeded areas without immediate repair.

3.2.1.4 Mulch

Mulching is the application of a protective layer of suitable mulch material to the soil surface. Straw mulch, compost mulch and/or hydromulch or Bonded Fiber Matrix (BFM) are also used in conjunction with seeding of critical areas for the establishment of vegetation. Mulching soils provides immediate protection from erosion. Mulch also enhances plant establishment by conserving moisture, holding fertilizer, seed, and topsoil in place, and moderating soil temperatures. For multi-year projects temporary mulch is a valuable resource for stabilizing soils during seasonally suspended work.

3.2.1.4.1 Applications

- Seed cover (as discussed in previous section).
- Dust control
- Soil cover on areas that can't be seeded or are otherwise unfavorable for plant growth.
- As temporary stabilization on bare soils exposed by construction activities. Refer to Section 00280, for specific requirements.
- On slope greater than 1V:2H, or where the mulch is susceptible to movement by wind or water, the mulch (straw, compost or other) should be fixed in place with hydraulically applied tackifier or mulch could be anchored mechanically.

3.2.1.4.2 Advantages

- Provides rapid protection.
- Conserves moisture.
- Allows vegetation growth through the mulch.
- Protects seeding from heat, moisture loss and transport due to runoff.
- Straw mulch is inexpensive and easy to install (even by hand).
- Straw mulch is an excellent emergency material.
- Compost mulch's dark color captures heat, aiding germination.
- Compost mulch adds nutrients and soil biology
- Compost mulch will provide erosion prevention during dry season and remain a good seed bed for permanent seeding when seeding window opens.
- Compost mulch removes material from "waste stream".

3.2.1.4.3 Disadvantages

- Thick mulches can delay germination.
- Can be blown or washed away if not adequately tackified.
- Temporary mulches must be removed prior to applying fill material.
- Straw mulch may introduce a road hazard if cattle or wildlife graze on straw mulch applied to roadsides.

- Straw mulch will contain seeds of parent crop which may be undesirable with permanent seeding.
- Straw mulch when used as temporary mulch must be removed prior to application of permanent seeding.

Design Criteria

- Divert concentrated runoff from mulched areas.
- Specific material and application criteria are included in Section 00280 and 01030.
- Refer to Appendix D for Mulch Application Rate Worksheet.

3.2.1.4.4 Organic Mulches

- Straw mulch provides immediate temporary protection lasting approximately three months. Straw can be spread mechanically or by hand and may require anchoring for wind protection. Correct application of straw mulch will leave no exposed soils. Common anchoring methods include crimping, disking, rolling; spraying with a tackifier; or keeping it moist. The combination straw mulch and tackifier is well suited to provide temporary stabilization on steep slopes, critical areas and severe climate conditions. Because straw mulch will contain seeds of its parent crop, straw mulch is not recommended for use with permanent seeding. If used for temporary cover it is recommended that straw mulch be removed prior to seeding
- Use no straw that is moldy, caked, decayed or of otherwise low quality. Submit verification from the supplier that the straw is free of noxious weeds. Acceptable documentation submitted shall show either (1) that the straw is from an "Oregon Certified Seed" field or (2) the seed lab results of the seed harvested from the straw meet minimum Oregon Certified Seed quality for weed seed content (refer to Appendix D). The minimum requirements of Oregon Certified Seed are as published in the current year's [Oregon Certified Seed Handbook](#), and lists of farms with certified fields that sell to the public are available from County Extension Offices or Oregon State University.
- Paper fiber hydromulch products are generally little more than a carrier for hydraulically applied seed. These should not be relied upon to provide any erosion protection prior to seeded plant establishment. Paper fiber mulch is for seed application on relatively flat



Figure 3-6 Good cover with straw mulch

sites that are not located near sensitive areas. Paper fiber mulch should be free of printing ink or any component harmful to plant growth.

- Wood cellulose, straw cellulose and other natural fiber hydromulch products are commonly combined with tracer dye and tackifier and applied hydraulically. They provide limited soil protection for a short duration and are weakened when wet and provide no protection against flowing water.
- Bonded Fiber Matrix and High Performance Growth Media are robust mulches that provide stabilization that does not rely on seed germination to provide protection. The installed product has loft, pore space and the ability to hold moisture, all features that contribute to seed germination. These mulches are manufactured so the fibers interlink and form a hydraulically applied matting. They have heavier application rates and provide a longer period of protection to exposed soils than other hydraulically applied mulches. These hydraulically applied mattings do resist sheet flow runoff but are not able to provide protection against concentrated flows. These products are usually pre-packaged to include tracer dye and tackifier.
- Wood chips and bark are suitable mulches soil covers for areas that will not be mowed and areas around ornamental plantings. Chips decompose slowly and require nitrogen application to prevent nutrient deficiency in plantings. Both wood and bark chips float and will wash down slopes when subjected to flowing water.
- Corn stalks, may be used with Engineer's approval for temporary soil cover.
- Manure mulches have applications in planting and as fertilizer, but are not recommended for use in erosion control applications.
- Compost mulch or compost blanket is commonly used both as erosion protection and as a growing media for seeding. Use coarse or medium compost conforming to the criteria described in Section 03020. Compost is specified in Specification 00280. Seeding on compost is specified in Section 01030. Compost mulch described in Section 01040 regards its use during planting. It is important to use the compost texture (particle size) specified. Compost that is too fine retains water and is shown to slip off slopes when heavy and lubricated with water. The benefits of using compost for mulch are many:
 - Construct compost blanket as shown in [Standard Detail DET6017](#)
 - Compost blanket dissipate rain splash energy, protecting the soil.
 - Compost retains water, diminishing runoff volume.
 - Compost slows runoff velocity and facilitates infiltration into the soil which further diminishes the volume of runoff.
 - Compost's dark color captures heat which aids germination and helps extend growing season into the autumn.
 - Compost helps soil retain moisture.
 - Seed, tackifier and bio-amendments can be applied concurrently with application of compost using metering material mixer with compost blower.
 - Compost provides nutrients for plants and jump-starts soil biology in soils.
 - Compost is a repurposed waste product that removes material from the waste stream.
 - Compost with tackifier can adhere to slopes 1V:2H that are too steep to receive soil preparation.

- Compost blanket can be installed at any time to cover soil to prevent erosion (conditions permitting). Seeding can be applied to previously applied compost with good success once the seeding window opens.

3.2.1.4.5 Maintenance of Mulches

- Maintain the thickness of the cover in all areas.
- Inspect mulched areas after installation and periodically inspect thereafter as required by NPDES permit
- Specification Subsection 00280.61 requires any areas that experience erosion be repaired to reestablish effective functioning of BMPs. If the erosion problem is drainage related, fix the drainage problem and re-mulch the eroded area.
- If sheet flow or other erosion damages mulch cover, then cause of erosion must be addressed then repair of mulch treatments is necessary.
- If mulch was applied without seed for erosion and dust control, the material must remain effective for the length of time the soil will remain without vegetation.
- Mulched and seeded areas that fail to establish vegetative cover adequate to prevent erosion shall be re-mulched as soon as such areas are identified, or other BMP used to address issue.
- Mulch does not protect against flowing water. If mulched areas are damaged by concentrated runoff, then prompt implementation of additional practices and BMP's to address the source of erosion are necessary.

3.2.1.4.6 Common Failures

The most common problems with mulches are:

- Inadequate coverage
- Poor installation and maintenance
- Improper selection of mulch and tackifier
- Deterioration from wind
- Removal by water without replacement.

3.2.1.5 Hydraulic Application

Hydraulic application is an efficient, fast and a proven method of application for certain mulches. Hydroseeding is a standard method for the application of seed and mulch. Hydroseeders can be used to uniformly apply materials such as mulch, tackifier, dust control chemicals, soil amendments, and others onto slopes. Mulches used for hydroseeding are commonly packaged to include tracer/dye and tackifier with the mulch fiber. Bonded Fiber Matrix mulch or other robust hydromulches are expensive. Considering this, contractors may benefit if they apply the mulches at less than the specified application rate. When hydromulch is installed the correct application is to spray from two different directions so that surface irregularities do not block the complete coverage of the soil.



Figure 3-7 Thin hydromulch application

3.2.1.5.1 Applications

- For applying seed, fertilizer, mulch, tackifier, soil amendments, bonded fiber matrix, and chemical stabilization.
- Slopes steeper than 1:3 that cannot receive adequate seedbed preparation.
- On sites where the application of a hydraulically applied bonded fiber matrix or high performance growth media systems are desirable.
- On sites where other soil stabilization, seeding, and mulching practices would result in unacceptable levels of ground disturbance.
- Where site conditions, such as irregular soil surfaces, existing vegetation, and shallow soils preclude the installation of erosion blankets and mats.
- On sites where straw mulch has been applied and the straw needs to be anchored (tacked) with tackifiers or hydraulic mulches.
- On sites where dust control is desired.
- For seed application over compost blanket.
- Refer to Appendix D for the [Hydroseeding Mixture Worksheet](#).

3.2.1.5.2 Advantages

- Provides rapid installation.
- Less expensive than broadcast or seed drilling operations.
- Requires less seedbed preparation.

- Uniformly distributes seed and mulch material when applied correctly.
- Increases favorable conditions for quick germination and growth.
- Can be used effectively on steep slopes and other areas where access is limited.

3.2.1.5.3 Disadvantages

- Requires mobilization and use of specialized equipment.
- Thick mulch applications can delay germination.
- Thin mulch applications do not provide adequate soil protection. If seed is included in hydromulch, that seeding application rate may not meet specifications.
- Can be blown or washed away if not adequately tackified.
- Know the distance that a hydroseeding gun can spray. Slopes may be longer than that equipment can reach (see photo above). Phased hydroseeding during construction can allow equipment access before slopes get larger than the capability of the hydroseeder.
- It may be necessary to apply in phases with applications installed prior to work areas becoming inaccessible.
- Required application rates can vary significantly dependent type of mulch used, site conditions, methods of preparation and slope.

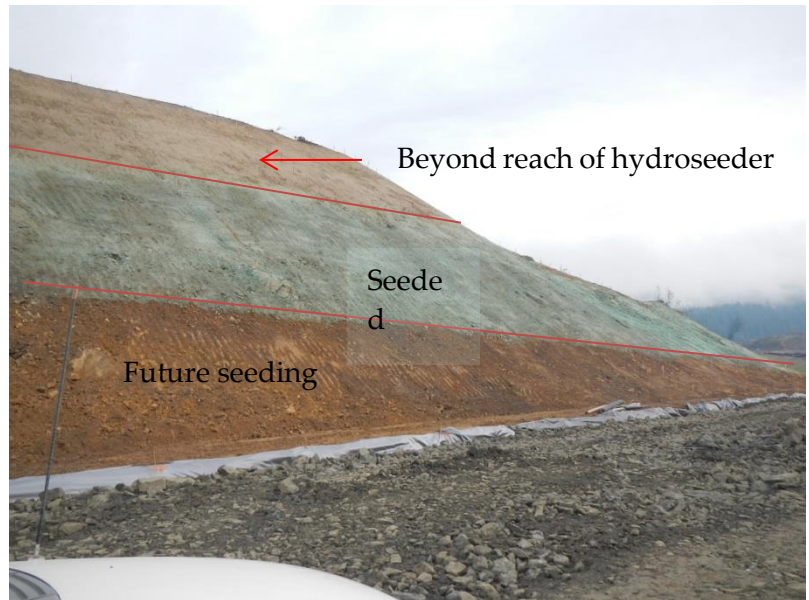


Figure 3-8 Plan for seeding/mulching long slopes

3.2.1.6 Sod

Establishes permanent vegetation for immediate erosion protection and stabilizes drainage ways. Sod is usually comprised of turf grass, however contract-grown sod, for specific purposes, can contain plants for wetlands, bio-swales, wildflower meadows or other types of immediate vegetative cover. Turfgrass installed as sod is a premium product that is used in high visibility areas or where immediate grass coverage is necessary.



Figure 3-9 Installation of wetland sod

3.2.1.6.1 Applications

- Disturbed areas requiring short-term or long-term cover.
- Areas that require immediate permanent turf grass cover.
- Disturbed areas requiring immediate vegetative cover.
- Waterways carrying intermittent flow (except biofiltration swales) and requiring immediate stabilization or aesthetic mitigation.
- When used around field or ditch inlets, sod will slow runoff and settle out sediment. For Sod Protection see [Standard Drawing RD1010](#) located on the ODOT web page on the Engineering Standards page in the [Roadway Section](#).

3.2.1.6.2 Advantages

- Provides immediate, effective protection, and is aesthetically pleasing.
- Provides high-density vegetation, which is superior to a recently seeded area.
- Density of sod vegetation prevents weed seeds from contacting soil, discouraging weed infestations. Areas with permits that require coverage with native plants, may find contract grown native plant sod to be the best option.
- Placement can occur any time that soil moisture is adequate and the ground is not frozen.

3.2.1.6.3 Disadvantages

- Expensive.
- Maintenance intensive.
- Availability is seasonal.
- Rarely integral to permanent landscape treatment and may require removal.
- Irrigation may be required if installed in summer.
- Difficult to mow if installed on slopes steeper than 1:3.
- Installation in grassed waterways may roll up if not anchored or drained properly.
- Requires good site preparation.
- Time necessary for root establishment may be lengthy.

3.2.1.6.4 Design Criteria

- Use sod that is weed free, has uniform thickness (approximately 1 in. thick) and dense root mat for mechanical strength.
- Turf sod is inappropriate for bioswales. Sod can be used for lining ditches to prevent erosion, but will provide limited water quality benefit during the wet season.
- The following steps are general recommendations for sod installation. Refer to Specification Section 01040 for specific installation criteria.
 - Shape and smooth the surface to final grade in accordance with the approved grading plan.
 - Fertilize, amend and condition soil per soil test recommendations. Use only non-phosphorous fertilizer near water bodies and wetlands.
 - Lay sod strips perpendicular to the direction of water flow, beginning at the lowest area to be sodded. Wedge strips securely into place and square the ends of each strip to provide for a close, tight fit. Stagger joints at least 1 ft. Staple sod onto 1:3 and steeper slopes.
 - Roll the sodded area with a water filled roller and irrigate.
 - When sodding is carried out in alternating strips or other patterns, seed the areas between the sod immediately after sodding.

3.2.1.6.5 Maintenance

- Inspect sodded area frequently for soil moisture content and root establishment. Drying sod will have a dull appearance and not spring back when stepped upon.
- Re-tack, re-sod, or re-seed as necessary.
- If it is impossible to establish a healthy ground cover due to frequent saturation, instability, or some other cause; remove the sod, seed the area with an appropriate mix, and protect with matting.

3.2.1.6.6 Common Failures

The most common problems with this BMP are:

- Poor site preparation
- Insufficient watering
- Poor soil contact
- Improper selection of sod type
- Poor soil fertility.

3.2.1.7 Matting



Figure 3-10 fully biodegradable slope protection matting

Numerous rolled erosion control products (RECPs) are available that use the names matting, blankets, fabric and nets. In ODOT they are all called matting. A wide range of materials and combination of materials are used to produce matting including, but not limited to: straw, jute, wood fiber, coir (coconut fiber), plastic netting, geosynthetic matrixes. Bonded Fiber Matrix and high performance growth media are hydraulically applied products that satisfy the requirements of matting. ODOT has recently revised our specification requirements to make products the first 5 (lightest duty) categories fully biodegradable.

This revision eliminates matting types that are constructed in layers with random natural fibers stitched between two layers of plastic netting. The monofilament plastic netting was ensnaring small animals and not breaking down in the landscape.

Equivalent products that are fully biodegradable are readily available at similar cost. Some use natural fiber netting to sandwich the fiber scrim. Others make a single layer matting of woven construction using biodegradable fibers. There are an abundance of biodegradable products to satisfy almost every level of protection.

Matting provides robust slope protection. Slope matting is engineered to allow vegetation to grow through it. Matting provides slope protection during the time needed to establish vegetation. Matting includes also a family of products called Turf Reinforcement Mats. These are high strength geosynthetic (plastic) products that provide permanent reinforcement of soil against flowing water and allow plants to grow through the material. This results in armored slopes/channels that blend with the appearance of the surrounding landscape.



Figure 3-11 Plastic netting at 5 years

The type of matting used for a site can make a significant difference in the effectiveness of the BMP. ODOT accepts matting materials that have been tested and approved by the Texas DOT/TTI Hydraulics and Erosion Control Laboratory meeting performance criteria for the following categories as listed in Section 00280.14(e):

- Type A – Fully biodegradable slope protection mat for slopes 1:3 or flatter – clay soils.
- Type B – Fully biodegradable slope protection mat for slopes 1:3 or flatter – sandy soils.
- Type C – Fully biodegradable slope protection mat for slopes steeper than 1:3 – clay soils.
- Type D – Fully biodegradable slope protection mat for slopes steeper than 1:3 – clay soils.
- Type E – Fully biodegradable flexible channel liner for shear stress from 0-2 pounds per square foot.
- Type F – Flexible channel liner for shear stress from 0-4 pounds per square foot.
- Type G – Flexible channel liner for shear stress from 0-6 pounds per square foot.
- Type H – Flexible channel liner for shear stress from 0-8 pounds per square foot.
- The current [Qualified Products List](#) includes approved matting materials and other erosion control materials that have been vetted as appropriate.
- Install matting according to Standard Drawing [RD 1055](#).

3.2.1.7.1 Applications

- On disturbed areas that require cover for more than 30 days.
- For robust and long term (up to 2 years) stabilization of slopes 1V:2H or steeper and with long slope lengths to provide vegetation to become fully established.
- For permanent reinforcement of turf to protect drainage ways during high flows.
- For permanent stabilization of channels, possibly providing a cost-effective, environmentally preferable alternative to riprap.
- For drainage ditches and swales. The appropriate netting or blanket used in drainage ditches and swales can protect bare soil while vegetation is being established.
- On steep slopes and in channels to prevent erosion and hold seed and mulch in place.

3.2.1.7.2 Advantages

- Immediate cushioning against splash erosion from raindrop impact.
- Slows runoff velocity.
- Retains moisture – reducing runoff
- Provides temporary slope protection during seeding establishment.
- Captures sediment in its open, porous structure.
- Vegetation can grow through products
- Usually easy to install.
- Products can be cost effective

3.2.1.7.3 Disadvantages

- Soil surface must be graded smooth to provide complete contact between soil and matting.
- Correct installation is critical to the effectiveness of these products. Good ground contact prevents runoff from rilling under the matting. Check slots, designed to check rills, are difficult to construct.
- Products can be expensive.
- When used as flexible channel liner the right material must be selected. Flowing water can strip fibers from between netting on lighter duty netting.

3.2.1.7.4 Design Criteria

- Apply seed and fertilizer prior to matting
- Apply matting according to Section 00280.44(e) and [Standard Drawing RD1055](#). This requires removal of all debris and undulations larger than 2 in. in any dimension and smoothing of soil surface.
- When selecting matting consider the following questions:
 - How long will the matting be required to provide protection?
 - How steep is the slope?
 - What is the soil type?

- What is the anticipated shear stress of concentrated flows of water?
- Add check slots on long slopes to prevent rilling under matting. A double band of staples, staggered, 4 inches apart across the slope will also prevent rilling underneath the matting.
- Natural fiber matting materials (excelsior, jute, burlap, cotton and coir) are biodegradable and provide stabilization for up to two years. Jute and straw when used in sandwich type matting have relatively short functional lives. Excelsior lasts longer and coir products can remain functionally effective for two years or more. Natural fiber matting provides all the functions of synthetic blend matting but also retains moisture and provides organic matter to the soil.
 - Jute netting can be used in conjunction with mulch in order to prevent erosion that could result from the net's open structure.
 - Excelsior (aspen wood fiber), straw, and coir (coconut fiber) blankets may be installed without mulch because they provide complete surface protection.
 - Strong protection is provided by woven coir matting which is available in multiple levels of strength and protection.
 - Synthetic mats are made from non-biodegradable material. Use purely synthetic blankets for long-term stabilization of waterways where permanent reinforcement of the channel vegetation is required.
 - Turf Reinforcement Mats (TRM) are made from geosynthetics formed into a 3-dimensional mat. TRM's protect seeds to facilitate germination and also intertwine with the plant's root structure; giving the turf higher strength.
 - Hybrid products exist of TRM that is pinned to the soil surface using steel cables and dart type earth anchors. This system prevents shallow planar slides.
 - Erosion Control and Revegetation Mats (ECRM) are commonly used in slope protection. They are composed of random scrim of natural fibers stitched between netting, also made from natural fibers. ECRM acts as mulch, protecting the soil and holding seeds in place. ODOT's specification Section 00280.14(e) require ECRMs to be fully biodegradable.
 - Channel Liner Matting or swale applications ([Standard Drawing RD1055](#)):
 - Seed prior to installation of matting (install live plants through installed matting where specified)
 - Lengthwise overlap: Min. 12" shingle type overlap starting at bottom of channel. Crosswise overlap: Min. 6 in.
 - Staple all matting edges at 12" O.C. Staple matting field in triangle pattern at 24" O.C.
 - Anchor upstream end of mat in anchor trench.
 - Do not join material in center of ditch or swale.
 - Slope application ([Standard Drawing RD1055](#)):
 - Seed prior to installation of matting.
 - Lengthwise overlap: Min. 2 ft.
 - Crosswise overlap: Min. 6 in.
 - At top of slope, entrench material in an anchor trench per the Standard Drawing RD1055.

- At bottom of slope, extend mat 2 ft. beyond the toe of the slope, turn material under 4 in.
- Staple all matting edges at 12" O.C. Staple matting field in triangle pattern at 24" O.C.
- On slopes flatter than 1:3, rolls can be placed in horizontal strips.
- Install matting so it has intimate contact with the soil surface.

3.2.1.7.5 Maintenance

- Inspect periodically, especially following severe storms.
- Repair any damaged areas of the net or blanket and staple into the ground any areas not in close contact with the ground surface.
- If erosion occurs, repair and protect the eroded area.

3.2.1.7.6 Common Failures

The most common problems are:

- Poor site preparation
- Leaving irregularities that prop matting above the soil surface (tenting)
- Poor installation, not following the manufacturer specifications
- Insufficient maintenance
- Improper blanket selection
- Improper placement of soil staples
- Concentrated flows under matting (rills)
- Subsurface flows (seeps) causing erosion under matting.
- Bonded fiber matrix (hydraulically applied matting) may fail if installed during wet weather.

3.2.1.8 Compost Blankets

Compost Blanket is a layer of medium or coarse compost installed to a thickness of 2 inches on exposed soil. This soil cover is installed as an erosion prevention material, but it is also a good seeding bed and it introduces soil biology into the poor soils that are common on roadsides. It is important to use the texture of compost specified in Section 00280.14(f) as compost that is too fine in texture will not be free draining and can slough off slopes when saturated. It is important also to install compost blankets with a tackifier. Properly installed a compost blanket will adhere to slopes as steep as 1V:2H and provide a good seed bed while protecting the slope.

3.2.1.8.1 Applications:

- On disturbed areas that require cover for more than 30 days.
- For robust stabilization of slopes 1V:2H and with long slope lengths to provide vegetation to become fully established.
- On long slopes, can be installed in conjunction with fiber rolls.

- On sterile mineral soil slopes to jump-start soil biology.
- For a fertile seed bed for permanent seeding.
- Instead of matting where no flowing water is anticipated.
- On steep slopes or flat areas to prevent erosion.

3.2.1.8.2 Advantages

- Immediate cushioning against splash erosion from raindrop impact.
- Slows runoff velocity.
- Retains moisture, reducing runoff volume
- Provides temporary slope protection during seeding establishment.
- Compost provides soil stabilization during seed germination and establishment.
- Captures sediment in its open, porous structure.
- Provides soil nutrients. Fertilizer not necessary when using compost blanket
- Vegetation germinates readily and sends roots easily into compost
- Dark color captures heat which aids in germination during cooler months
- Easy to install using pneumatic blower or high speed conveyor.
- Sequesters carbon
- Product is repurposed waste material, removing volume from the waste stream.

3.2.1.8.3 Disadvantages

- Correct texture of compost may not be in stock in materials yards (Suppliers will screen correct texture lots when asked).
- Can slough off slopes if fine texture is used, or if compost is not installed with tackifier.
- Requires specialized equipment to install.
- Does not offer protection against flowing water.
- Aroma during installation not considered pleasant.

3.2.1.8.4 Design Criteria

- Apply compost blanket after loosening surface soils. Compacted soils must be loosened to allow seed root penetration prior to installation of compost blanket and roughened surface diminishes slip plane between materials.
- Apply seed concurrently with compost installation or after using hydroseeder.
- Apply compost blanket according to Section 00280.44(f) and [Standard Detail 6017](#). When used with seeding reference the 01030 Section. Install Compost Blankets on roughened soil surfaces as described in 00280.43.
- When selecting compost blankets consider the following questions:
 - How steep is the slope?
 - How long is the slope?
 - What is the soil type?

- Will composted area be receiving stormwater runoff as well as rainfall?

3.2.1.8.5 Maintenance

- Inspect periodically, especially following severe storms.
- Install new compost and seed in areas damaged by flowing water or other damage.
- If erosion occurs, repair and protect the eroded area.

3.2.1.8.6 Common Failures

The most common problems are:

- Wrong compost texture used.
- Tackifier not used. Compost slides off slope.
- Stormwater runoff not sufficiently controlled upslope of compost blanket
- Compacted soils underneath compost did not allow root penetration.
- Smooth soil underneath compost forms slip plane that allows compost to slide off slope.



Figure 3-12 Compost blankets provides erosion prevention

3.2.1.9 Insufficient maintenance Plastic Sheeting

Plastic sheeting provides immediate, short-term protection to slopes and disturbed areas that cannot be mulched. Plastic sheeting has been known to transfer erosion problems because water will sheet flow off the plastic at high velocity, requiring BMPs at the bottom of plastic covered slopes. Plastic sheeting is an excellent material to have on site as an emergency material. For general erosion prevention, use alternatives to plastic sheeting whenever possible.

- Refer to [Standard Detail: DET 6001](#) Plastic Sheeting, located on the ODOT web page on the Engineering Standards page in the [Roadway Section](#).

3.2.1.9.1 Applications

- On disturbed areas that require cover for less than 30 days.
- On cut and fill slopes and stockpiles.
- To construct a flume to convey concentrated flow down slope. Requires energy dissipater at toe of slope.
- Use when vegetation cannot be established to protect soil during rainy season on small areas. For larger areas consider matting (Section 3.1.1.7 of this Chapter).

- Can be used alone or in conjunction with sediment fences, and/or diversion dikes.
- As emergency material to stabilize pop-out failures, rilling or other erosion issues.
- Plastic sheeting can be used in conjunction with flocculent sediment treatment in channels.
- Plastic sheeting can be used to isolate trench drains or blanket drains from surface water flows that carry potentially sediment laden water.
- When using straw bales as the structure, plastic sheeting can line structure to be water tight concrete washout basin



Figure 3-13 Plastic sheeting runoff control on slope matting

3.2.1.9.2 Advantages

- Provides immediate, short-term erosion protection to slopes and disturbed areas.
- Fairly quick and easy to install.
- Plastic sheeting is inexpensive.

3.2.1.9.3 Disadvantages

- Plastic sheeting may concentrate sunrays and burn the vegetation beneath it.
- Material generates high velocity runoff.
- Plastic breaks down quickly and becomes more fragile when exposed to ultraviolet radiation.
- Plastic, when it is not completely removed, can clog drainage system inlets and outlets.
- If not properly anchored, wind may shred plastic and litter the landscape, perhaps onto roadways, creating traffic hazard.
- Plastic never fully degrades but degenerate into smaller pieces. Small particles can enter the food chain where they are harmful. In the best case plastic enters the waste stream and is disposed of according to Section 00290.20.

3.2.1.9.4 Design Criteria

- Install plastic sheeting as shown in [Standard Detail DET6001](#)
- Do not use plastic covering upslope of areas such as steep and/or unstable slopes that might be adversely affected by concentrated runoff.

- When used, construct perimeter control or energy dissipation at the bottom of slopes that are covered with plastic sheeting.
- When possible, install an inceptor dike at the top of the plastic to divert flows away from the plastic.
- Anchor top of the sheeting in a 6 in. x 6 in. trench backfilled with compacted native material.
- Weight the plastic sheeting in place using sandbags or other suitable tethered anchoring system spaced not less than on a 10 ft. grid spacing.
- Overlap seams 1 ft. to 2 ft.; tape, roll and staple the seams and then weigh down the entire length.

3.2.1.9.5 Maintenance

- Replace torn sheets and repair open seams.
- Completely remove and replace plastic when it begins to deteriorate.
- Completely remove all plastic once it is no longer needed.
- Check anchoring system and repair or add anchors.
- Verify effective functioning of BMP at toe of slope

3.2.1.9.6 Common Failures

The most common problems with plastic sheeting are:

- Improper plastic sheeting selection
- Failure to anchor plastic sheeting into place
- Failure to place of suitable protection at the slope toe.
- Wind or UV radiation damage plastic sheeting.

3.2.1.10 Shorten Slope Length

Flowing water on slopes grows more erosive over distance. The runoff combines with water on already saturated ground and with the additional moisture of falling rain gains volume. As the water flows downslope it picks up more abrasive sediment and its velocity increases, making it more erosive. To address these forces sediment barriers are installed on the face of slopes parallel to contours at prescribed intervals. The sediment barriers intercept flowing water, checking its velocity and stop rills from forming. Among the sediment barriers that are used to shorten slope length are: fiber rolls, sediment fences, compost socks and compost berms. They are listed in the Section of this Manual dealing with sediment control – 3.4.4. Sediment barriers that impound water on slopes can over-saturate soils and contribute to the development of shallow planar slides.

3.2.1.11 Dust Control

Preventative measures to minimize the wind transport of soil. Dust clouds are a nuisance, they can affect the health of persons with breathing problems and dust commonly results in

complaints from the public. Some of the worst dust issues result from on-site haul routes or worse, dirt tracked onto pavement and churned into dust by construction traffic. ODOT strives to be a good neighbor so prevention of fugitive dust is important.

3.2.1.11.1 Applications

- On construction routes and other disturbed areas subject to surface dust movement and where off-site damage may occur if dust is not controlled.

3.2.1.11.2 Advantages

- Reduces movement of soil to offsite areas.
- Increases visibility.

3.2.1.11.3 Disadvantages

- Over watering may cause erosion.
- Most methods require immediate reapplication if disturbed.

3.2.1.11.4 Design Criteria

- Minimizing the area of exposed soil reduces the potential source of dust.
- Dust control is covered in Sections 00280, 00340 and 01030 of the ODOT Specifications; the designer can provide project-specific dust control Special Provisions for the contractor to apply. Measures include:
 - Seeding – Dust season (usually summer) rarely coincides with the seeding window. Seeding with mulch and tackifier will provide some dust control during the time it takes for vegetation to become established but watering (and PM's approval) is necessary to establish seeded vegetation during dry and dusty weather.
 - Mulching – Straw tacked or crimped in place will provide dust control. Straw must be removed prior to seeding. Compost blankets tacked in place provide dust control and can be seeded directly when seeding window arrives.
 - Matting – Matting can be expensive, but is excellent dust abatement.
 - Rocking Access Roads – Dirt roads will generate less dust if surfaced with aggregate.
 - Water – Common dust abatement measure. Needs repeated applications. Water delivery systems are difficult on slopes. Watering access roads is a successful BMP.
 - Tackifier – Chemical tackifier; polyacrylamide, can be applied with hydroseeding equipment or on roads, water truck.
 - Chemical Soil Stabilizers or Liquid Stabilized Emulsions – see [ODOT Qualified Product List](#). In some areas, these must be approved prior to use. Some of these products form crust on soil that must be broken prior to seeding.
 - Installation construction entrances and stabilizing construction haul roads with crushed rock.
 - Removal of dust generating material from pavement using vacuum sweeper.

- Schedule construction operations so that the least amount of project area is disturbed at one time.

Install temporary or permanent dust abatement measures immediately after completing land grading. Soil exposure limitations are described in Specifications Section 00280.42. Stabilize soils disturbed by construction within 7 days if within 100' of water and within 14 days otherwise. East of the Cascades, during summer, Project Manager can waive soil exposure requirements if conditions warrant.

3.2.1.11.5 Maintenance

- Maintain dust control measures through dry weather periods until all disturbed areas have been stabilized.
- Re-stabilize areas disturbed by contractor's operations or other activities (wind, water, vandalism, etc.) within 2 days of disturbance.

3.2.1.11.6 Common Failures

The most common problem occurs when using water to control dust:

- Over watering which may cause erosion
- Failure to re-apply dust control measures after initial application is disturbed
- Failure to vacuum sweep dirty pavement

3.3 Runoff Control Practices

The erosive potential of flowing water and its ability to carry sediment is increased on the exposed soils of construction sites. High volume and velocity flows easily move sediment and other pollutants into streams, wetlands, and lakes. Stormwater flowing through a project could originate off site or on site. Controlling stormwater runoff that flows through a site, regardless of its origin can be accomplished through basic strategies. These are controlling the location of stormwater runoff and decreasing runoff velocities.

Controlling the location of stormwater will occur during earthwork, whether it is planned or not. Grading will determine the catchment area of on-site watersheds, the direction of stormwater flow and the volume and velocity of runoff. Earthwork conducted with purposeful shaping of the land, considering runoff control, can simplify erosion control and diminish risk.

Runoff control BMP's that control the location of runoff include pipe slope drains and diversion swales. During construction, planning the shaping of the land to control of runoff can make the implementation of runoff control BMP's more successful. Runoff control BMP's that reduce runoff velocities include check dams and sediment traps.

Best Management Practices

1. Temporary Slope Drain

2. Lined Channel
3. Outlet Protection
4. Surface Roughening
5. Check Dam
6. Interceptor Dike and Interceptor Swale
7. Stormwater Control

3.3.1 Temporary Slope Drain



Figure 3-14 Temporary Slope Drains

To control the location of stormwater runoff, temporary Slope Drains are pipes extending from the top to the bottom of a slope and discharging into an energy dissipater or scour hole that is strengthened to withstand erosion. The pipe slope drain carries concentrated runoff down steep slopes without causing erosion, or saturation of slide-prone soils. Another method to convey runoff down a steep slope is to construct a flume with plastic sheeting.



Figure 3-15 Plastic sheeting used as Temporary Slope Drains

- Refer to details: [RD1045](#) Temporary Slope Drain, located on the ODOT web page on the Engineering Standards page in the [Roadway Section](#).

Applications

- On any slope where a large amount of flow must be collected and conveyed to avoid erosion.
- Areas where clean water should be kept separate from sediment-laden water. If a permanent measure is needed, it should be designed as part of the roadway drainage facilities.

Advantages

- Effective method of conveying water down steep slopes.
- Reduces or eliminates erosion.
- Easy installation and little maintenance.

Disadvantages

- Drain can be under-designed or incorrectly located.
- Area cleared for drain installation requires stabilization to prevent erosion occurring under the pipe.
- Outfall systems constructed of pipe segments, which are banded and/or gasketed together, could develop leaks causing erosion and failure of the system. Failures on erodible or steep slopes can cause downstream sedimentation or even mudflows.
- Adjustment of pipe lengths is necessary as cut and fill slopes are extended.

Design Criteria

- Size and space pipe slope drains to convey the peak flow from a 2-year design storm using the rational method found in [ODOT Hydraulics Manual](#). Estimate pipe diameter from the following table.

Table 3-2 Slope drain sizes

Contributing Drainage Area (Maximum)	Pipe Diameter
½ acre	12 in.
1 ½ acre	18 in.
3 ½ acre	24 in.

- Consider using continuously fused, welded or flange-bolted mechanical joint systems with proper anchoring or HDPP (high-density polyethylene pipe) for outfalls on steep slopes.
- Stabilize the area sloping toward the pipe inlet.
- At the inlet, show interceptor dikes that are at least 1 ft. higher at all points than the top of the inlet pipe and placed to direct water into the pipe.
- If the pipe slope drain will convey sediment-laden runoff, direct the runoff to a sediment basin/trap facility.
- In the runoff is not from a disturbed area or is conveyed from a sediment trap or pond, convey the runoff to a stabilized discharge point.
- Energy Dissipation – Outlet Protection consisting of Scour holes or riprap-lined stilling basins prevent most scour problems at outfalls (refer to Section 3.3.2 of this chapter).
- Consider site conditions to determine if a more complex energy dissipater may be required. Consult the [ODOT Hydraulics Manual](#).
- The special provisions and typical notes should include the following installation directions:
 - Minimize disturbance during installation. In some circumstances this requires HDPP installed by hand.
 - Slope anchor details.
 - Immediately stabilize any area disturbed during installation or maintenance.
 - Securely connect the standard flared end section at the entrance to the slope drain, using watertight connecting bands.
- Pipe should be staked securely to prevent movement.
 - Securely fasten together the slope drain sections with gasketed watertight fittings, and securely anchor the sections into the soil.
 - Stabilize the area below the outlet following the energy dissipater.

Maintenance

- Adjust lengths of pipe when cut and fill slopes are extended.
- Regularly check the inlet and outlet points, especially following heavy rains. If there are signs of undercutting or water is going around the point of entry, reinforce the head wall with compacted earth or sand bags.
- Regularly check connection points for signs of erosion. Tighten fittings and repair erosion as needed.
- Immediately repair and install appropriate protection if erosion occurs at the outlet.

Common Failures

Common problems occur when:

- Connections are not watertight
- Stabilization along the slope at the inlet or outlet was incorrectly installed
- When pipes that are undersized
- When pipes are incorrectly located for flow actually occurring onsite.

3.3.2 Outlet Protection

Culvert, drain pipe, and other stormwater conveyance discharge locations require energy dissipaters to diminish the erosive force of the water exiting the pipes. A scour basin constructed from riprap (or other durable materials) at the discharge point of the pipe will reduce the speed of concentrated flow and prevent scour erosion at the conveyance outlets. By dissipating energy, the temporary scour basin lowers the potential for downstream erosion.

- Refer to Standard Drawing [RD1050](#) Temporary Scour Basin / Energy Dissipater, located on the ODOT web page on the Engineering Standards page in the [Roadway Section](#).

Applications

- At the outlets of ponds, pipe slope drains, ditches, or other conveyances, and where runoff is conveyed to a natural or man-made drainage feature such as a stream, wetland, lake, or ditch.

Advantages

- Many techniques are effective, relatively inexpensive, and easy to install.
- Reduces velocity and erosive energy.

Disadvantages

- May be difficult to remove sediment without removing and replacing the structure itself.
- Rock outlets with high velocity flows may require frequent maintenance.

Design Criteria

- Use the standard drawing [RD1050](#) for outlet protection as a minimum. Consider site conditions to determine if a larger or more complex energy dissipater may be required.
- Water from outlet protection should discharge into a stabilized channel or over a level spreader to eliminate the concentrated flow.
- Refer to the [ODOT Hydraulics Manual](#) for specific criteria.

Maintenance

- If there is scour at the outlet, repair and revise by increasing the size of the energy dissipater facility.
- Remove accumulated sediment frequently.

Common Failures

The most common problem with outlet protection is:

- Underdesign
- Failure to remove accumulated sediment
- Rock that is too small and/or is not angular enough for the runoff velocities (river run or rounded rock is not adequate).



Figure 3-16 Energy Dissipater (permanent installation)

3.3.3 Surface Roughening

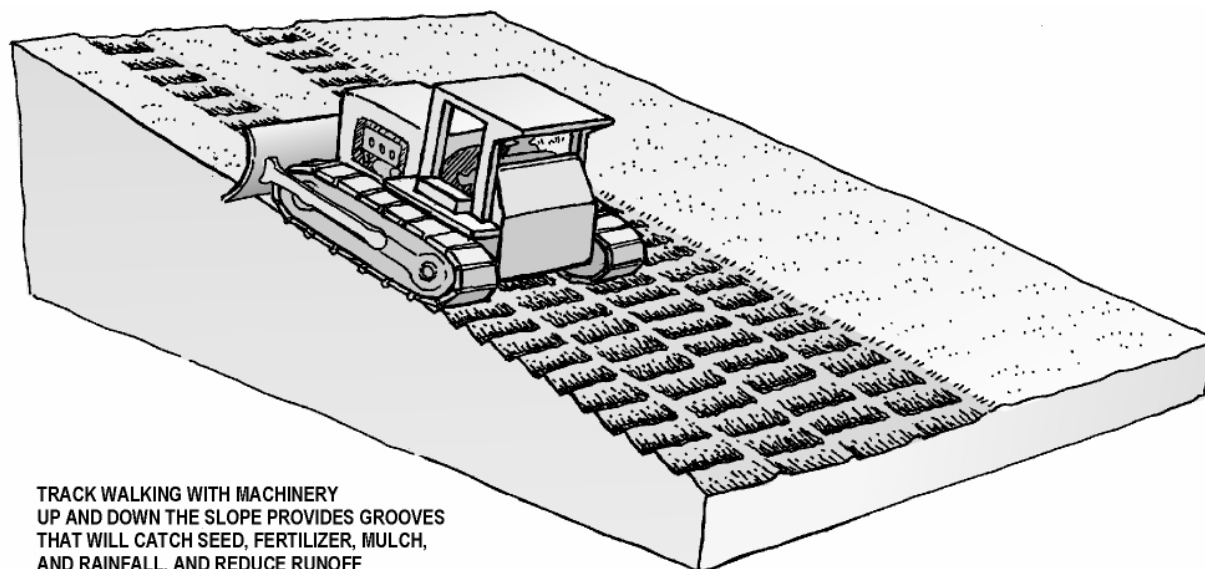


Figure 3-17 Surface Roughening

Leaving the slopes in a roughened condition after clearing or creating a rough soil surface with horizontal depressions or grooves will trap seed and reduce runoff velocity. Depressions or grooves must be parallel to contours. The most convenient method of surface roughening is 'track walking' slopes with tracked equipment. This does however compact the soil to a degree and may inhibit root penetration by vegetation. Other roughening methods use a serrated wing blade attached to the side of a bulldozer, or by other agricultural equipment capable of loosening the soil to a depth between 3 and 6 inches. This activity is a site preparation prior to seeding and is not to be considered a finished or temporary treatment. Surface roughening provides no protection against flowing water.

Surface roughening is not to be confused with soil compaction. Use tracked equipment when surface roughening that is small and light enough that it will not appreciably compact the soil. Compaction of the soil will limit seed germination and growth. Do not roughen surface of areas that are to be stabilized with matting. Matting must be applied to smooth surfaces.

Applications

- All embankment slopes to be seeded.
- On cut slopes 1V:1.5H or flatter (01040.48(d))
- Prior to installation of compost blanket
- All slopes steeper than 1:3 having a vertical rise of 5 ft. or greater.

Advantages

- Grooves trap seed.

- Increased vegetation establishment.
- Reduces runoff velocity, increases infiltration.
- Traps soil eroded from the slopes above.

Disadvantages

- Vegetated slopes cannot always be easily maintained by mowing.
- Tracking with a bulldozer or tracked equipment may compact the soil.
- Do not rely upon as means of erosion control.

Design Criteria

- Slope roughening is required as site preparation in Standard Specifications sections 00280.43 and 01040.48 for areas to be seeded for both temporary and permanent seeding
- Immediately seed and mulch roughened areas to obtain optimum seed germination and growth.
- Texture surface using track grousers not less than 1 3/8 in. or greater.
- Track walking should be accomplished by driving equipment up and down slope to create depression parallel to contours.

Cut Slope Roughening

- Stair-step grade or groove the cut slopes that are steeper than 1:3
- Use stair-step grading on erodible material soft enough to be ripped with a bulldozer. Slopes consisting of soft, uniform texture, rock particularly suited to stair-step grading.
- Make the vertical cut distance less than the horizontal distance, and slightly slope the horizontal position of the "step" in toward the vertical wall.
- Do not make individual vertical cuts more than 2 ft. high in soft materials or more than 3 ft. in rocky materials.
- On cut slopes 1V:1.5H or flatter, roughen the surface with furrows parallel with slope contours and loosen the soil to a depth between 3 inches and 6 inches (01040.48(d)).
- Install compost blanket with tackifier.
- Hydroseed using bonded fiber matrix as mulch.

Fill Slope Roughening

- Place fill slopes with a gradient steeper than 1:3 in lifts not to exceed 8 in., and make sure each lift is properly compacted.
- Ensure that the face of the slope consists of loose, uncompacted fill 4 to 6 in. deep. Use horizontal grooving along the contour or tracking to roughen the face of the slopes, if necessary.
- Install compost blanket with tackifier to slope using pneumatic blower or high speed bulk material conveyor.
- Hydroseed using bonded fiber matrix as mulch.

Cuts, Fills, and Graded Areas

- Use Special Provision subsection 00330.42(c)(3) requiring that the outer 12 inches of embankments are constructed with material suitable for the establishment of seeded vegetation.
- Make slopes intended to be mowed no steeper than 1V:3H.
- Roughen these areas to shallow grooves by normal tilling, disking, harrowing, or use a cultipacker-seeder. Make the final pass of any such tillage on the contour.
- Make grooves formed by such implements close together, 12 in. maximum spacing, and not less than 1 in. deep.
- Excessive roughness is undesirable where mowing is planned.
- Compost blanket with seeding provides a smooth surface that can be mown once grass and vegetation have established.

Maintenance

- Periodically inspect the seeded slopes for rills and wash outs. Fill these areas slightly above the original grade, then re-seed and mulch as soon as possible.

Common Failures

The most common problem with surface roughening:

- Excessive soil compaction
- Inadequate vegetation establishment
- High velocity runoff causing rill or gully erosion
- Tracking in wrong direction.

3.3.4 Check Dam



Effective functioning check dams with sediment impounded behind each dam.

Figure 3-18 Check Dam

Small dams constructed across a swale or ditch to check the velocities of concentrated flows. Check dams prevent erosion in the channel where they are installed by preventing erosive flow velocities. Check dams reduce sediment leaving the site by allowing sediment to fall out of suspension in the slower water. Note that check dams using straw bales are not approved for use.

- Check Dams can be constructed from a variety of materials.
 - Type 1 – Aggregate: Aggregate material.
 - Type 2 – Straw Wattle or Fiber Roll staked ground (with or without a sediment catchment sump).
 - Type 3 – Bio-filter Bags: Bio-filter bags staked to the ground.
 - Type 4 – Sand Bags: Sand bags with or without an aggregate weir.
 - Type 5 – Pre-fabricated Check Dam System: A manufactured system specifically designed to slow water so that suspended particles settle out. Also, Pre-fabricated systems may be designed to filter stormwater, retaining sediment and allowing treated water to pass. Field-fabricated systems are not allowed.
 - Type 6 – Compost Filter Sock staked to ground (with or without a sediment catchment sump).
- Refer to Standard Details [RD1005](#) and [RD1006](#) - located on the ODOT web page on the Engineering Standards page in the [Roadway Section](#).

Applications

- In temporary or permanent channels not yet vegetated.
- In small open channels that drain 10 acres or less.
- Install temporary check dams in Water Quality Treatment Swales and maintain until vegetation fully stabilizes facility.
- Do not place check dams in streams or rivers.
- Types 2, 3, 4 and 5 are suitable for use as emergency materials

Advantages

- Prevent gully erosion and promote settling of sediment in runoff.
- When thoughtfully located and correctly constructed, check dams may function as permanent installations.
- Inexpensive and easy to install.
- May aerate water as it passes the check dams.
- Aggregate can be spread into ditch and used as a channel lining when the check dam is no longer necessary.
- Some pre-fabricated check dams are reusable.

Disadvantages

- Measures may be unsightly.
- Removal may be costly for some types of check dams.
- Suitable only for a limited drainage area.
- May reduce hydraulic capacity of the channel.
- May create turbulence downstream, causing erosion of the channel banks if incorrectly installed.
- Effective functioning check dams require maintenance to remove captured sediment.
- Ponded water or accumulated sediment may kill grass in grass-lined channels.
- May be an obstruction to construction equipment.

Design Criteria

- Check dams are spaced so that the bottom of an upslope check dam is at the same elevation as the top of the next downslope check dam. This results in slow water pools behind each check dam where sediment can fall out of suspension. Space check dams according to the following table.

Table 3-3 Spacing for check dams

Ditch Grade	H=8"	H=12"	H=18"	H=24"
Maximum Check Dam Spacing "L"				
10%	**	**	15'	20'
9%	**	**	16'	22'
8%	**	**	18'	25'
7%	**	**	21'	28'
6%	**	16'	25'	33'
5%	**	20'	30'	40'
4%	16'	25'	37'	50'
3%	22'	33'	50'	66'
2%	33'	50'	75'	100'

** Not Allowed

- Construct rock check dams of angular, durable aggregate sized to stay in place given the expected design flow velocity, typically 1 in. to 4 in. diameter as described in Section 00280.15(a). Place rock or aggregate by hand or by mechanical means rather than dumping the rock.
- Completely cross the ditch or swale width and ensure the center of the dam is 6 inches lower than the wings of the dam to prevent side-cutting erosion and keep flows centered in the channel.
- Remove check dams from grass-lined ditches and swales once the grass is established.
- Seed and mulch the area where the check dams were located immediately following removal.

Maintenance

- Periodically inspect check dams for performance and sediment accumulation.
- Remove sediment once it reaches one-third the depth of the check dam. Place removed sediment where it will not reenter the channel

Common Failures

Common problems with check dam performance are:

- Incorrect spacing and installation
- Inadequate rock size or angularity

- Low point of check dam not centered
- Inadequate maintenance - sediment removal
- Sidecutting around the wings of the check dam
- Compost sock material made of biodegradable fabric may be insufficiently strong to be moved/removed intact.
- Not maintaining check dam integrity.

3.3.5 Diversion Dike/Diversion Swale

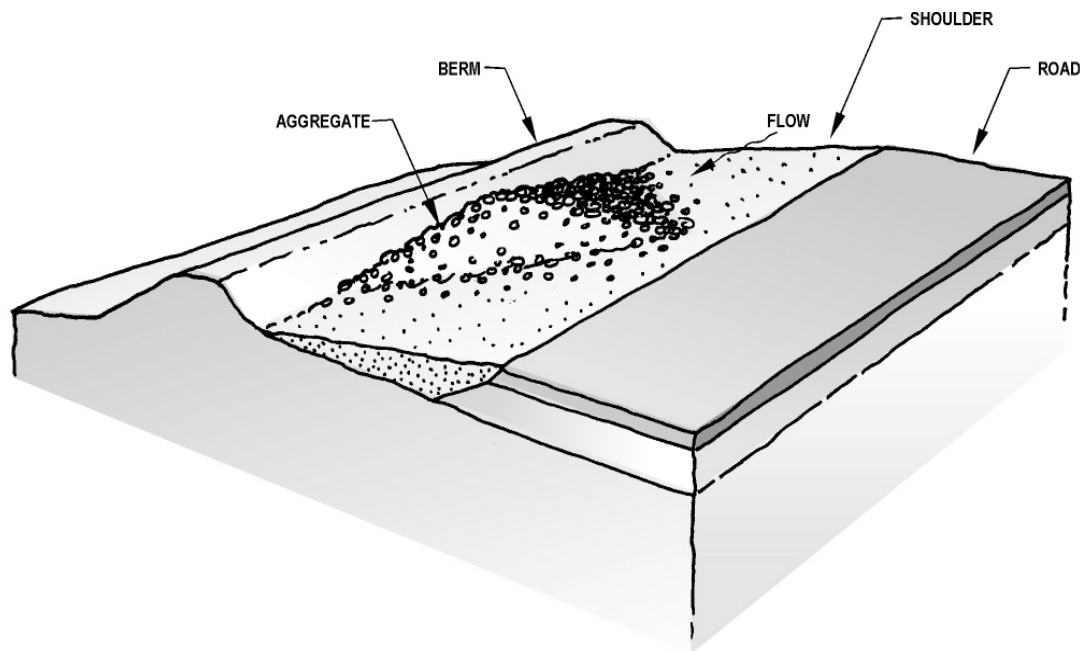


Figure 3-19 Interceptor Dike/Interceptor Swale

A ridge of compacted soil or a stabilized swale located at the top, base or somewhere along a sloping disturbed area. The dike or swale intercepts and conveys smaller flows along low-gradient drainage ways to larger conveyances such as ditches or pipe slope drains or to a stabilized outlet. Dikes and swales may be used alone or in combination with each other.

Refer to details:

- [DET 6007 Temporary Interceptor Dike Type 1,](#)
- [DET 6008 Temporary Interceptor Dike Type 2,](#)
- [DET 6009 Temporary Interceptor Dike Type 3,](#)
- [DET 6010 Temporary Interceptor Swale Type 1,](#)
- [DET 6011 Temporary Interceptor Dike/Swale Type 3,](#)

Details are located on the ODOT web page on the Engineering Standards page in the [Roadway Section](#).

Applications

- Install above a disturbed slope to intercept runoff and reduce runoff volume on the disturbed area.
- Install below a disturbed area to divert runoff to a sediment-trapping device.
- Install across a disturbed slope to reduce runoff velocity.

Advantages

- Provides a practical, inexpensive method to divert runoff.
- Can handle flows from large drainage areas.
- Use onsite material and equipment to construct.

Disadvantages

- If improperly constructed, can contribute to erosion caused by concentrating the flow.
- High flow velocity can damage vegetation.

Design Criteria

- Refer to Table [3-4](#) Dike Design Criteria and Table [3-5](#) Swale Design Criteria.
- Install the dike and/or swale horizontally at intervals across a disturbed slope.
- Space horizontal interceptor dikes and swales according to Tables 3-4 and 3-5.
- For slopes of erodible soils, steeper than 1:2 with more than 10 ft. of vertical relief, construct benches or shorten distance between dikes and swales.
- If the dike or swale intercepts runoff from disturbed areas, discharge the runoff to a stable conveyance that routes the runoff to a sediment trap or basin.
- If the dike or swale intercepts runoff that originates from undisturbed areas, discharge the runoff to a stable conveyance that will route the runoff downslope of any disturbed areas and release the water at a stabilized outlet.
- Do not use sediment fence to divert flows.
- Pipe collected flow under roads.

Table 3-4 Interceptor Dike/Interceptor Swale

Top Width	24 in. minimum
Height	20 in. minimum Measured from upslope toe and at a 90% standard proctor compaction ASTM D698.
Side Slopes	1:2 or flatter

Grade	Topography Dependent	
Dike Grade	Between 0.5-1%	
Slope of Disturbed Area vs. Horizontal Spacing	<5%	300 ft.
	5-10%	200 ft.
	10-25%	100 ft.
	25-50%	50 ft.
Slope Stabilization	<5%	
	Seed and mulch within 5 days of dike of disturbed construction	
Outlet	Upslope side of dike provides positive drainage to the outlet. Provide energy dissipation as necessary to prevent erosion. Release sediment-laden runoff to a sediment trapping facility.	

Table 3-5 Interceptor swale design criteria

Bottom Width	24 in. minimum. The bottom should be level across the swale.	
Depth	12 in.	
Side Slopes	1:2 or flatter	
Grade	Maximum 5% with positive drainage to a suitable outlet.	
Slope of Disturbed Area vs. Horizontal Spacing	<5%	300 ft.
	5-10%	200 ft.
	10-25%	100 ft.
	25-50%	50 ft.
Slope Stabilization	Temporarily seed, line with matting or line with riprap 12 in. thick and press into the bank approximately 3 in. to 4 in.	
Outlet	Level spreader or riprap to stabilize outlet/sedimentation pond.	

Table 3-6 Interceptor swale spacing design criteria

Slope	Swale Spacing
3 – 5%	300 ft.
5 – 10%	200 ft.
10 – 25%	100 ft.
25 – 50%	50 ft.

Maintenance

- Immediately repair damage resulting from runoff or construction activity.
- If the dike or swale regularly overflows, increase the capacity and/or frequency of the dikes/swales.
- Inspect and repair as necessary after every major storm.
- Minimize construction traffic over temporary dikes and swales.
- Clean out clogged pipes (as part of the swale system) under roads.

Common Failures

The most common problems with interceptor dikes and swales result from:

- Inadequate stabilization causing erosion along the base of a dike or the bottom of a swale
- Undersized construction for flows actually occurring onsite.

3.3.6 Stormwater Control:

- Ponds
- Water Quality Bio-Filtration Swale
- Water Quality Bio-Slope
- Water Quality Filter Strip

These four features are designed permanent features to treat stormwater runoff to remove pollutants from finished projects. These are not erosion or sediment control BMPs, but the overlap in their functions with the intent of this manual rightly includes them in the list. The purposes of these features is to use vegetation, infiltration and the action of microbes in the soil to treat pollutants in the stormwater runoff from pavement. The need for these features is prompted by the endangered species act and the presence of federally listed salmon species in waters of the Pacific Northwest. Each of these features is a unique design fitted to the project conditions by a hydraulic engineer.

Appreciate that these features receive stormwater runoff that is sometimes high volume and velocity. When used on project plans work with hydraulic engineer to ensure that suitable erosion control measures are in place to protect these features.

The Stormwater Control Pond is over excavated, then (usually) fitted with an underdrain and brought to finished grade with a highly organic, well-drained Water Quality Soil Mixture. The surface is armored with open cell pervious pavers and the cells are infilled with more soil mixture. A stabilized outfall prevents erosion from water leaving these ponds. The soil is then planted or seeded. The Boilerplate Special Provision for Stormwater Control Ponds is [Section 01011](#).

The Stormwater Control Bio-Filtration Swale is over excavated, then (usually) fitted with an underdrain and brought to finished grade with highly organic, well drained Water Quality Soil Mixture. The surface is armored with open cell pervious pavers and the cells are infilled with

more soil mixture. Weirs may be used to control flow velocity in the swale. A stabilized swale outfall prevents scour from water leaving these swales. The soil in the open cell pavers is then planted or seeded. The Boilerplate Special Provision for Stormwater Control Ponds is [Section 01012](#).

The Stormwater Control Bio-Slope is over excavated, then (usually) fitted with an underdrain and brought to finished grade with a mineral Ecology Mix "soil". Bio-Slopes are built into surfaces down slope from pavement and treat sheet flow from the pavement. The Boilerplate Special Provision for Stormwater Bio-Slopes is [Section 01013](#).

The Stormwater Control Filter Strip is over excavated, brought to finished grade with a highly organic, well-drained Water Quality Soil Mixture. Filter Strips are built into surfaces down slope from pavement and use infiltration, vegetation and microbial activity to treat sheet flow from the pavement. The Boilerplate Special Provision for Stormwater Filter Strips is [Section 01014](#).

Three of these four features is over excavated and backfilled with a well-drained soil mixture. This soil mixture is lightweight, porous and very erodible. The mineral "Ecology Mix" is likewise fine textured and erodible. Permanent stabilization is provided by vegetation, either seeded or planted, but there is always a strong likelihood that significant volumes and high-energy velocities of stormwater runoff will be routed into these facilities prior to vegetative stabilization. These features require erosion prevention that does not rely on plant establishment. ODOT has recently introduced salt as a means to address ice on roads. It is unknown how road salt effects water quality facilities or the plants that help provide treatment. Coordinate Erosion Control design with hydraulic engineer. Stormwater control design can be made more durable against erosion with the use of Turf Reinforcement Mats (TRM), which are among the high performance matting types, Types F, G and H.

Applications

- Areas where concentrated runoff contain pollutants from pavement and have the potential to cause damage from erosion or flooding.
- Areas where sheet flow runoff contain pollutants from pavement and have the potential flow untreated into waterways
- Areas where volumes of stormwater runoff containing pollutants from pavement have the potential to exceed the volumes of runoff of pre-construction conditions.

Advantages

- Features can moderate high velocity runoff.
- Vegetation (once established) provides channel protection and treats pollutants
- Captures sediment due to the filtering effect of vegetation.
- Aquatic ecosystems benefit from diminished pollution.
- Permit requirements are satisfied by implementation.

Disadvantages

- Rain events that occur prior to vegetation establishment can result in erosion damage strong enough to dismantle feature.
- May require temporary irrigation to establish vegetation.
- May require channel liner matting and/or check dams during vegetation establishment
- Vegetation may become buried in sediment if upslope watershed does not have sufficient erosion prevention in place.
- Unless reinforced with matting, cannot be used until vegetation is established.
- Features require ongoing maintenance

Maintenance

- Maintenance and operations manual should be provided by designer.
- During the initial establishment, damaged vegetation should be repaired and re-established if necessary.
- After vegetation has become established, the feature should be checked periodically to verify effective functioning and stability of feature.
- Check the feature for debris, scour, or erosion and immediately make repairs. It is particularly important to check the feature outfall for evidence of piping or scour holes and make repairs immediately.
- Remove all significant sediment accumulations to maintain the designed carrying capacity.
- Keep the vegetation in a healthy, vigorous condition at all times, since it is the primary erosion protection for the channel.
- Permanent vegetated waterways should be seasonally maintained by mowing and/or irrigating, depending on the type of vegetation selected.
- Newly seeded areas need to be inspected frequently to ensure the vegetation is growing.
- If the seeded area is damaged due to runoff, additional storm water measures such as check dams or matting may be needed.
- Spot seeding can be done on small areas to fill in bare spots where grass did not grow properly.

Common Failures

- Improper seed selection with species selection either being too water loving or too drought tolerant for site conditions.
- Vegetation not adequately established to provide erosion prevention prior to the introduction of stormwater
- Inadequate site preparation
- Unmet maintenance increases and risk of failure.

3.4 Sediment Control Practices

Once soil erosion occurs, sediment trapping or removal techniques can reduce the amount of sediment that leaves the site. Sediment is pollution so its removal protects receiving rivers, wetlands, and lakes. Sediment controls are usually placed around the perimeter of a disturbed area and where concentrated water leaves the site. Sediment control BMP's should be in place before land clearing and grading begins. It is important to note that sediment controls, if poorly maintained, can become sources of sediment and other pollutants during larger storms.

Best Management Practices

- 1) Construction Entrance
- 2) Tire Wash Facility
- 3) Road/Staging Area Stabilization
- 4) Sediment Barrier / Perimeter Control
 - a) Biofilter Bags
 - b) Straw Rolls (Wattles)
 - c) Compost Socks
 - d) Compost Berm
 - e) Sand Bags
 - f) Brush Barrier
 - g) Filter Berm
 - h) Pre-fabricated Barrier System
- 5) Sediment Fence / Perimeter Control
- 6) Flocculent treatment
- 7) Inlet Protection
- 8) Sediment Trap
- 9) Sediment Basin

3.4.1 Construction Entrance

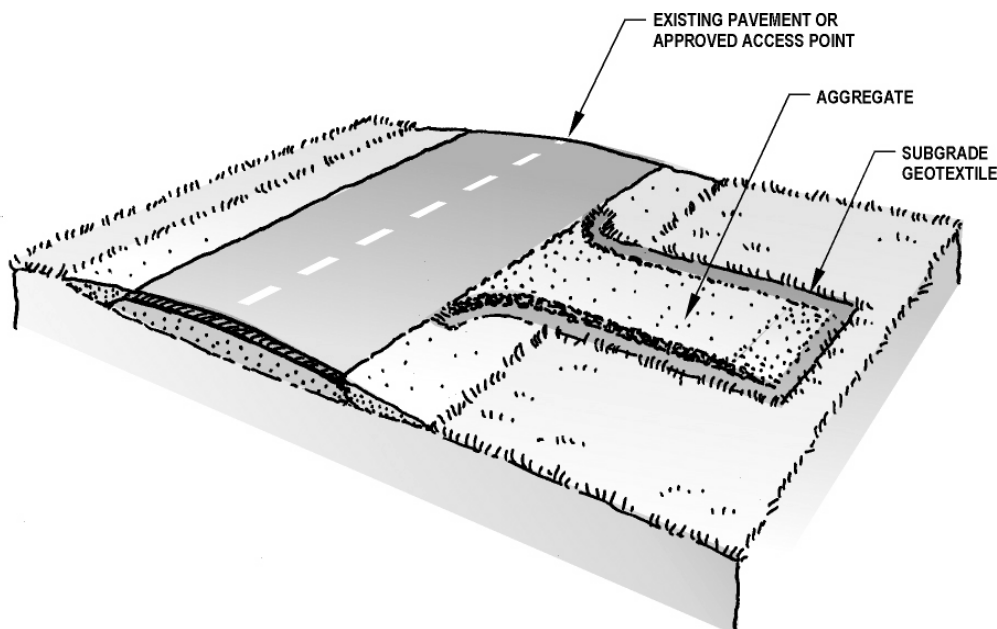


Figure 3-20 Construction Entrance

A stabilized aggregate pad, placed at construction site ingress/egress locations. Construction entrances reduce the amount of sediment transported onto paved roads by vehicles. Manufactured or custom-built rumble strips or shaker plates can function as construction entrances. Pre-fabricated construction entrance panels are available that are manufactured from bright yellow, high-molecular-weight polyethylene. These panels are reusable, recyclable, will not become clogged with sediment and are easily cleaned.

- Refer to detail: [RD1000 Construction Entrance Temporary](#), located on the ODOT web page on the Engineering Standards page in the [Roadway Section](#).

Applications

- Wherever traffic will be leaving a construction site at a rate of at least 25 trips per day and traveling on paved roads or other paved areas located within 100 ft. of the site.
- The 1200-CA Permit (Schedule A, Subsection 3.c.i) requires that each site shall have graveled, paved or constructed entrances, exits and parking areas to reduce the tracking of sediments onto public or private roads.

Advantages

- Reduces traffic hazards caused by debris on public roadways.
- Reduces sediment on roadways that can wash into the storm sewer system.
- Reduces public nuisance and misperceptions regarding Agency “housekeeping”.

Disadvantages

- Only effective if erosion and sediment control employed elsewhere onsite.
- Only works if installed at every location where significant construction traffic leaves the site.
- Fills with sediment quickly and requires frequent maintenance and/or replacement of rock.

Design Criteria

- Length:
 - 20 ft. for drainage areas having less than 0.25 acre of exposed soil.
 - 50 ft. for drainage areas having between 0.25 and 1 acre of exposed soil.
 - 100 ft. for drainage areas having more than 1 acre of exposed soil
- Minimum width: 20 ft.
- Minimum Aggregate Depth: 8 in.
- Coarse, open graded, durable aggregate sized as described in Section 00280.16(a)
- Install at construction entrances before beginning grading.
- Whenever possible, construct the pad on a firm, compacted subgrade.
- Place a geotextile under the aggregate when fine sediment under the pad could “pump” up and into the pad.
- Do not install aggregate on paved surfaces.
- Install fencing as necessary to restrict construction vehicle traffic to the construction entrance.
- Include a tire wash if the entrance does not prove effective in retaining sediment onsite.

Maintenance

- When aggregate becomes clogged with sediment perform maintenance by replacing rock, topping construction entrance with new, clean rock or by “stirring” the construction entrance aggregates with bladed equipment to reopen voids between the rocks and to maintain the effective functioning of the construction entrance
- Immediately sweep up and remove any sediment that is tracked onto pavement. Vacuum sweeper trucks can perform this task.
- If the sediment poses a threat to public safety and street sweeping proves ineffective, consider washing the street and collecting the water in a sediment pond or sump before it leaves the site. Never wash sediment into stormwater systems or into ditches or waterways.
- Add aggregate, replace aggregate or with a bladed piece of equipment “stir” the aggregate to renew void space as needed to maintain the specified dimensions and.
- Immediately remove any aggregate, which gets carried from the pad to the roadway.
- Maintain fencing installed as traffic control.

Common Failures

- The most common problem with this BMP is the failure to provide correct type of rock and adequate depth and length of rock entrance.
- Failure to perform maintenance to keep construction entrance effective functioning.
- Failure of truck operators to correctly use construction entrance.

3.4.2 Tire Wash Facility

Washing equipment tires not only prevents mud from tracking onto pavement, this practice can prevent the spread of noxious weeds that might have seeds stuck in the soil on tires. Two types of tire wash facilities are shown as Standard Drawings that can be used based on the severity of sediment tracking and the size of the project. Type 1 is a stabilized aggregate pad similar to a stabilized construction entrance that is graded or otherwise constructed to collect wash water and convey it to a sediment trap, basin, or other suitable treatment facility. The Type 1 facility includes a steel rumble strip or cattle guard structure to shake sediment from tires and a water supply and hose with which to wash vehicle tires. Type 2 consists of a shallow water-holding basin partially filled with water, through which exiting vehicles drive. Prefabricated tire wash facilities or purpose built tire wash facilities that include pumps, and water spray directed to truck or equipment tires can provide superior tire wash results. Prefabricated tire wash facilities are available for rent or purchase. For purpose built facilities, provide shop drawings for approval prior to installation.

- Refer to [Standard Drawing RD1060](#) Tire Wash Facility, located on the ODOT web page on the Engineering Standards page in the [Roadway Section](#).

Applications

- Wherever traffic will be leaving a construction site and traveling on paved roads or other paved areas located within 100 ft. of the site. Where sediment removal on a stabilized construction entrance alone is inadequate to prevent tracking.

Advantages

- Reduces traffic hazards caused by debris on public roadways.
- Reduces sediment on roadways, which can wash into the storm sewer system.
- Type 1 is easy to construct and is relatively inexpensive.
- Type 2 is useful for high traffic volumes or large projects of long duration.

Disadvantages

- Only works if installed at every location where construction traffic leaves the site.
- Fills with sediment quickly and requires frequent maintenance.
- Requires a source of wash water.

- Requires a turnout or doublewide exit to avoid entering vehicles having to drive through wash area.
- Type 1 requires labor to wash the tires of all vehicles exiting the site.
- Type 2 is costly to construct.
- Type 2 will generate large volumes of sediment-laden water, requiring treatment elsewhere on site.

Design Criteria

- Type 1
 - Minimum length: 81 ft.
 - Minimum width: 10 ft.
 - Minimum Aggregate Depth: 12 in.
 - Fit with cattle guard as rumble strip
 - Place subgrade geotextile under the aggregate.
 - Provide with water supply and hose.
 - Install fencing as necessary to restrict existing construction vehicle traffic to the tire wash.
 - Grade the pad to drain to suitable collection and treatment facility.
- Type 2
 - Basin dimensions 41 ft. long by 15 ft. wide with sloping ingress and egress, and 50 ft. long impervious runoff area at egress, which drains into basin.
 - Line bottom of basin with geotextile and 1 ft. of open graded aggregate.
 - Provide water supply.
 - Provide outlet for sediment-laden water discharge to treatment facility or provide pumps and tanks for water treatment.

Maintenance

- Type 1
 - Wash pad when sediment clogs aggregate.
 - Add or re-grade aggregate as needed.
 - Immediately remove any aggregate that gets carried from the pad to the roadway.
 - Ensure that wash water drainage, collection and treatment system is functioning.
- Type 2
 - Remove/discharge wash water as needed.
 - Remove accumulated sediment from bottom of basin.
 - Ensure that wash water collection and treatment system is functioning.

Common Failures

- The most common problem with this BMP is failure to use or maintain the facility.
- Failure to control turbid wash water that drains off vehicle leaving the tire wash.

3.4.3 Construction Road/Parking Area Stabilization

Stabilized parking areas and onsite vehicle transportation routes reduce erosion caused by construction traffic or runoff.

Applications

Permanent or temporary roads or parking areas used by construction traffic.

- The 1200-CA Permit requires that all unpaved roads located onsite shall be graveled. Other effective erosion and sediment control measures either on the road or down gradient may be used in place of gravel.



Figure 3-21 Stabilized Haul Road

Advantages

- Reduces onsite erosion, dust, and offsite tracking of soils.
- Can speed and enhance efficiency of onsite work.

Disadvantages

- Temporarily stabilized construction roads can be expensive to install and maintain.
- At the end of their use, temporary haul routes must be tilled to eliminate compaction prior to seeding.

Design Criteria

- Road and parking area stabilization may not be necessary during the dry season (unless dust is a concern) or if the site is underlain by coarse-grained soils.
- ODOT usually leaves temporary road locations and construction criteria to the contractor's discretion. The following is general information regarding road and parking stabilization:
 - Stabilize roads and parking areas immediately after initial grading.
 - Whenever possible, construction roads and parking areas should be placed on firm, compacted subgrade.
 - Engineers designing haul roads should work to keep road grades as flat as is practicable. Erosion control designers are not qualified to design haul roads.

- Where on-site roads are cut into slope faces, construct water bars or diversion ditches to move water down slope at sufficiently frequent intervals so that concentrated flows are avoided.
- Grade roadways to encourage sheet flow runoff to a roadside ditch or to a heavily vegetated area. Do not direct runoff into vegetated wetlands or landscaped areas. Discharge runoff through at least 50 ft. of vegetation to treat the sheet flow runoff. Treating sheet flow runoff from temporary roads is preferred to using a sediment pond or trap.

Maintenance

- Immediately following grading, apply crushed rock, gravel base or crushed surfacing base course. A course of asphalt-treated base (ATB) or cement may also be used.
- Install fencing, if necessary, to limit vehicle access to stabilized roads and parking areas.
- Add crushed rock, gravel base, as required to maintain a stable driving surface and to stabilize any eroded areas.

Common Failures

- The most common problem with this BMP is the failure to include adequate depth and length of rock, failure to maintain the rock depth for supporting heavy vehicles, and poor installation. Unpaved routes that function with no issues in dry weather can become soft and generate sediment pollution when weather becomes wet.
- Another common failure occurs after construction is completed. This failure is to abandon the haul route without loosening the soil or eliminating the compaction caused by heavy vehicle traffic. Compacted soils resist infiltration, increasing runoff and roots of plants cannot penetrate compacted soils and often die from not being able to access resources.

3.4.5 Sediment Barrier

Sediment barriers can be constructed from a variety of materials. Sediment barriers are most frequently used as perimeter control, as the last line of protection to keep sediment from leaving project sites. Sediment barriers are also used as intermediate protection and as the erosion prevention measure to shorten slope length. Sediment barriers function by stopping the downslope flow of sediment-laden water, allowing the suspended solids to settle out. Some sediment barriers function by impounding water so sediment can fall out of suspension. Other sediment barriers function by filtering out sediment. A listing of barrier types according to ODOT specifications and drawings follows:

- Type 1 – Straw Bales are not approved for use as sediment barriers.
- Type 2 – Biofilter Bags: Embedded biofilter bags staked to the ground.
- Type 3 – Fiber Rolls (Wattles): Embedded fiber rolls staked to the ground.
- Type 4 – Sand bags: Bags filled with sand or gravel.
- Type 5 – Brush Barrier: Entrenched and mounded woody materials or strippings.

- Type 6 – Aggregate Berm: Entrenched aggregate, mounded.
- Type 7 – Pre-fabricated Barrier System: A manufactured system specifically designed for temporary sediment control applications. Field fabricated systems are not allowed.
- Type 8 – Compost Filter Sock: Netting sleeve filled on-site with coarse compost.
- Type 9 – Compost Filter Berm: Low berm formed on-site using coarse compost. Wood chips may be substituted for compost with Agency approval

Table 3-7 Barrier spacing for general application

INSTALL PARALLEL ALONG CONTOURS AS FOLLOWS		
% SLOPE	SLOPE (V:H)	MAXIMUM SPACING ON SLOPE
< 10%	< 1:10	300 ft.
10 > % ≥ 15	1:10 > X ≥ 1:7.5	150 ft.
15 > % ≥ 20	1:7.5 > X ≥ 1:5	100 ft.
20 > % ≥ 30	1:5 > X ≥ 1:3	50 ft.
>30%	> 1:3	25 ft.

3.4.5.1 Straw Bale – Sediment Barrier Type 1

Not Approved for use as Sediment Barrier

3.4.5.2 Biofilter Bags – Sediment Barrier Type 2

Biofilter bags are manufactured from 100% recycled wood-product waste placed in plastic mesh bags. They are typically 30 in. long by 18 in. wide and weigh approximately 45 lb. Biofilter bags are very pervious and are most effective in settling out larger particle size sediments.

- Refer to detail: [RD1030](#) Sediment Barrier – Type 3 (and Type 2 & 4 Biofilter or Sandbags), located on the ODOT web page on the Engineering Standards page in the [Roadway Section](#).

3.4.5.2.1 Applications

- To capture and retain sediment on slopes.
- To capture sediment around drain inlets (see Inlet Protection, Type 4).
- To capture sediment and reduce water velocity on paved streets.
- To capture sediment and reduce water velocity in unlined and lined channels, swales or ditches.
- Can be staked in developing rills or gullies to capture sediment and reduce water velocity.

3.4.5.2.2 Advantages

- Relatively low cost.
- Installation is simple, can be transported and installed by hand.
- Bags are easy to move, replace and reuse on paved surfaces.
- Are good short-term solution in situations where concentrated flows are causing erosion (can be stuffed or staked in developing rills).
- Good BMP to store as emergency materials.
- Wood material can be dispersed on site so only the mesh needs disposal.

3.4.5.2.3 Disadvantages

- Provides minimal sediment control
- Generally effective for only a few months.
- Can be easily damaged or displaced by construction equipment or by traffic in paved areas.
- Can become clogged with sediment and cease to filter runoff.
- If not properly staked, will fail on slope applications.
- If improperly installed can allow undercutting or end-flow.
- Not effective where water velocities or volumes are high.
- Lightweight results in higher buoyancy if not properly installed.
- Low sediment retention capacity may require frequent maintenance.

3.4.5.2.4 Design Criteria

- On slope applications should be installed on contour.
- See Table 3-7 Barrier spacing for general application.
- Ends of bags must be tightly abutted and overlapped to direct flow away from bag joints.
- Install two stakes per bag when installed on soil.
- In paved areas weight in-place using sand bags (staking not feasible).

3.4.5.2.5 Maintenance

- Inspect biofilter bag installations after storms. Check that stakes are secure and ends of bags are tightly abutted. Check that undercutting or end-flow is not occurring.
- Check that flow is not becoming channeled behind bags (parallel to row of bags).
- Check that bags are not displaced.
- Inspect plastic mesh bags for tears.
- Remove sediment when 1/3 height of bag has accumulated.
- Replace damaged bags as needed. Remove wood chips spilled from damaged bags.

3.4.5.2.6 Common Failures

Failures most commonly result from biofilter bags not being tightly abutted together, which allows sediment-laden flow between or under the bags. This also occurs when bags are not properly staked. Another common failure is caused when the bags are not installed on contour

and water flow becomes channeled behind the bags. Bags are easily displaced when used on pavement and are easily broken when driven over.

3.4.5.3 Fiber Rolls (Wattles) – Sediment Barrier Type 3

Fiber rolls are manufactured from straw or other fibers that is wrapped in tubular netting. Specifications (00280.15(a)) require the enclosing netting be fully biodegradable. They are approximately 8 in. in diameter by 25 ft. to 30 ft. long. Fiber rolls are placed in shallow trenches and staked along the contour of newly constructed or disturbed slopes.

- Refer to detail: [RD 1030](#) Sediment Barrier (Type 3).



Figure 3-22 Fiber Rolls (Wattles) – Sediment Barrier Type 3

Applications

- To capture and retain sediment on slopes
- To shorten slope length
- To temporarily stabilize slopes by reducing soil creep and sheet and rill erosion until permanent vegetation is established.
- As perimeter control to prevent turbid water from leaving project site, entering waterways or paved areas.
- Suitable as emergency material
- Fully biodegradable fiber rolls do not need to be removed

Fiber rolls installed correctly:

- Installed on contour
- Shallow embedment
- End turned up-slope to prevent channeling runoff from flowing downslope (in this photo, turned up more than necessary)

3.4.5.3.1 Advantages

- Easier to deploy than sediment fences on steep slopes.
- Fiber rolls are a short-term solution to help establish native vegetation.
- Fiber rolls store moisture for vegetation planted immediately downslope.
- All natural fiber rolls may be left in place to biodegrade.

- Straw becomes incorporated into the soil with time, adding organic material to the soil and retaining moisture for vegetation.
- Reduces runoff velocity and shortens slope length (erosion prevention).
- Requires minimal ground disturbance to install.
- Lightweight and easy to install.
- Rocks rolling down slope usually do not damage straw wattles.
- Good BMP to keep on-site as emergency material.

3.4.5.3.2 Disadvantages

- Rolls only function for one or two seasons.
- Shallow trenching for the installation of fiber roll may be difficult on rocky ground.
- If not installed properly with sufficient trench, water may undercut roll.
- Fiber rolls may require maintenance to ensure that the stakes are holding and the rolls are still in contact with the soil. This is especially true on steep slopes in sandy soil.
- Low sediment retaining capacity may require frequent maintenance.
- Fiber rolls constructed with plastic netting to enclose the fiber must be removed and disposed of. Photodegradable netting still takes many years to break down.

3.4.5.3.3 Design Criteria

- Prepare the slope before the wattle installation is started.
- The use of fiber rolls constructed with fully biodegradable netting to enclose the straw is recommended because it does not require removal and disposal. Leaving biodegradable product on site adds organic matter to soil and does not add to waste stream.
- Surface irregularities should be smoothed as work progresses.
- Dig small trenches across the slope on contour to place rolls in. Space trenches in accordance with the Table 3-7 Barrier spacing for general application. The trench should be deep enough to accommodate one-third the thickness of the roll.
- Start building trenches and install rolls from the bottom of the slope and work up.
- Install rolls perpendicular to water movement, parallel to the slope contour.
- Lay the roll along the trenches fitting it snugly against the soil. Make sure no gaps exist between the soil and the straw wattle.
- Overlap roll ends 12" to ensure no gaps in protection
- When plant cuttings (live stakes) are used, install during the planting season described in Sections 01040.41 (west of the Cascades – September 1 through May 15) or 01040.42 (east of the Cascades – October 15 through November 30)
- When plant cuttings are specified, do not delay installation of fiber rolls by waiting for planting season. Stake fiber rolls with wooden (dead) stakes then, during the planting season, supplement the wood stake with plant cuttings.
- Use a straight bar to drive holes through the wattle and into the soil for the plant cuttings or wooden stakes.

- Drive the stake through prepared hole into soil. Drive a minimum of 12 in. into undisturbed material. When plant cutting is used, avoid damaging this living plant material to the greatest extent practicable.
- Install stakes not less than every 4 ft. apart through the wattle. Additional stakes may be driven on the downslope side of the trenches on highly erosive or very steep slopes.

3.4.5.3.4 Maintenance

- Inspect the fiber rolls and the slopes after significant storms. Make sure the rolls are in contact with the soil.
- Remove accumulated sediment when it is 1/3 the capacity of the fiber roll.
- Repair any rills or gullies promptly.
- Re-seed or replant vegetation if necessary until the slope is stabilized.

3.4.5.3.5 Common Failures

- Failures most commonly result from straw rolls not being installed with correct overlapping, allowing water to easily pass between the rolls, resulting in rilling.
- Water can scour beneath the rolls if they are not properly entrenched.
- Fiber rolls with plastic netting that are not removed become plastic litter and eyesores.

3.4.5.4 Compost Socks – Sediment Barrier Type 8

Compost socks are usually field fabricated sediment barriers made by blowing coarse compost into a mesh sleeve. Some distributors have available compost socks pre-filled in short lengths. The flexible nature of the sleeve combined with the weight of the compost causes the compost sock to conform to surface irregularities of the ground. Embedding compost socks is not necessary. The sock material can be plastic netting or (preferably) biodegradable netting made of burlap, cotton or other natural fiber. The sock material is available in diameters of 9, 12, 18 and 24 inches. The sock length is determined in the field.

- Refer to detail: [RD 1032](#) Sediment Barrier (Type 8).

3.4.5.4.1 Applications

- To capture and retain sediment on slopes.
- To shorten slope length, check runoff velocity on slopes and interrupt sheet and rill erosion (erosion prevention).
- As perimeter control to prevent turbid water from leaving project site.

3.4.5.4.2 Advantages

- Difficult to install incorrectly. Does not need to be embedded into soil.
- Compost is waste material repurposed as useful product.
- Sequesters carbon
- Removal of plastic compost sock mesh consists of cutting sock fabric and spilling compost out of fabric and disposing of the fabric only. Fully biodegradable compost socks do not need removal.
- Even as fully biodegradable sock material in contact with soil is decomposing, the BMP will continue to function.
- Compost Socks store moisture for vegetation planted immediately down slope.
- Compost becomes incorporated into the soil with time, adding organic material to the soil and retaining moisture for vegetation.
- Requires minimal ground disturbance to install.
- Rocks rolling down slope usually do not damage compost socks.



Figure 3-23 Compost Sock – Sediment Barrier Type 8

3.4.5.4.3 Disadvantages

- Requires specialized equipment to install. Not well suited to be specified as emergency material
- The required coarse compost may not always be stocked in material yards.
- Low sediment retaining capacity (depending on compost sock diameter) may require frequent maintenance.
- Removal of plastic netting from compost sock is required and can be difficult due to the weight of wetted compost.
- Biodegradable netting may not be sufficiently robust to be moved without rupturing if phased work required adjusting BMP locations.

3.4.5.4.4 Design Criteria

- Prepare the installation location by removing rocks, roots, branches and surface irregularities larger than 3" before the compost sock installation is started.
- The use of compost socks constructed with fully biodegradable netting is recommended where the BMP will not be moved because it does not require removal or material disposal.
- Install compost socks perpendicular to water movement, parallel to the slope contour.
- Overlap roll ends 12" to ensure no gaps in protection

- Use a straight bar to drive holes through the compost sock and into the soil for plant cuttings here specified.
- Install stakes not less than every 4 ft. apart through the compost sock. Additional stakes may be driven on the downslope side of the trenches on highly erosive or very steep slopes.
- Use 8" diameter compost socks on slopes. Larger diameter (heavier) compost socks are appropriate as perimeter control or on slopes 1V:4H or flatter.

3.4.5.4.5 Maintenance

- Inspect the compost socks and the slopes after significant storms. Make sure the socks are in contact with the soil.
- Repair any rills or gullies promptly.
- Re-seed or replant vegetation if necessary until the slope is stabilized.

3.4.5.4.6 Common Failures

- Failures most commonly result from compost socks not being installed with correct overlapping, allowing water to easily pass between the sock sections, resulting in rilling.

3.4.5.5 Compost Berms – Sediment Barrier Type 8

Compost berms are field fabricated linear mounds made by blowing coarse compost through a rolling mold or by placing compost along contour line with equipment. The weight and unconstrained nature of the compost causes the compost berm to conform to surface irregularities of the ground. Embedding compost berms is not necessary. Wood chips can be substituted for compost with Agency approval. Wood chips can be chipped from debris obtained from site clearing.

- Refer to detail: [RD 1033](#) Sediment Barrier (Type 9).

3.4.5.5.1 Applications

- To capture and retain sediment on slopes.
- To temporarily stabilize slopes by reducing soil creep and sheet and rill erosion until permanent vegetation is established.
- As perimeter control to prevent turbid water from leaving project site, entering waterways or paved areas.
- Fully biodegradable compost or wood chip berms do not need to be removed.

3.4.5.5.2 Advantages

- Difficult to install incorrectly. Does not need to be embedded into soil.
- Easy to repair with hand tools if damaged.
- Compost is waste material repurposed as useful product.

- Sequesters carbon
- Compost berm continues to function even as it is being incorporated into the surrounding landscape.
- Compost berms store moisture for vegetation.
- Reduces runoff velocity and shortens slope length (erosion prevention).
- Requires minimal ground disturbance to install.

3.4.5.5.3 Disadvantages

- The use of rolling mold and blower equipment to install compost makes installation quick with minimal labor.
- Construction of compost or wood chip berm with equipment such as backhoe can be time intensive.
- The required coarse compost may not always be stocked in material yards (Will be provided by suppliers when they are given adequate lead-time.)
- Compost berms only function for one or two seasons.
- Compost berm is not a robust sediment barrier. It may fail out in big weather events or where water becomes impounded behind berm. Rolling rocks or damage caused by construction equipment can render BMP ineffective.
- Not appropriate for specifying as emergency material

3.4.5.5.4 Design Criteria

- Prepare the installation area before the compost berm installation is started.
- Install compost berms perpendicular to water movement, parallel to the slope contour.
- Coarse compost must be used.

3.4.5.5.5 Maintenance

- Inspect the compost berms and the slopes after significant storms.
- Repair any rills or gullies promptly.
- Re-seed or replant vegetation if necessary until the slope is stabilized.

3.4.5.5.6 Common Failures

- Failures most commonly result from compost berms being installed on too steep a slope with too large a water catchment area.
- Failures can occur if too fine a compost texture is used.

3.4.5.6 Sand Bags – Sediment Barrier Type 4

Sandbags are manufactured from durable, weather resistant tightly woven material sufficient to prohibit leakage of the filler material. The bags should measure 24 in. by 12 in. by 6 in. and be filled with firmly packed PCC 3/8"-0 aggregate or round 3/8" – 3/16" pea gravel and weigh at least 75 lb.

- Refer to detail: [RD1030](#) Sediment Barrier, located on the ODOT web page on the Engineering Standards page in the [Roadway Section](#).
- (Type 2 & 4) Biofilter or Sandbags (sand bag and biofilter bag installation similar).

3.4.5.6.1 Applications

- To capture and retain sediment on slopes.
- To capture sediment around drain inlets.
- To capture sediment and reduce water velocity on paved streets.
- To capture sediment and reduce water velocity in unlined and lined channels swales or ditches.
- Can be placed in developing rills or gullies to capture sediment and reduce water velocity.
- Can be placed in streams for isolating work areas.
- Appropriate as emergency materials

3.4.5.6.2 Advantages

- Relatively low cost.
- Installation is simple, can be done by hand.
- Bags are easy to move, replace and reuse on paved surfaces.
- Are good short-term solution in situations where concentrated flows are causing erosion (can be placed in developing rills).
- Can be used to divert and slow velocity of small flows.
- Can be used in concrete lined ditches capture sediment and reduce water velocity (check dam, Type 4).

3.4.5.6.3 Disadvantages

- Generally effective for only a few months.
- Can be easily damaged by construction equipment.
- Can contribute sediment to runoff if bags rupture.
- Cannot be staked and are not appropriate on steep slope applications.
- Not effective in steep swales, channels or ditches.
- If improperly installed can allow undercutting or end-flow.
- If used on active streets, sand bags on pavement could cause motorcyclists or bicyclist to crash.
- Not effective where water velocities or volumes are high, can get dislodged.

3.4.5.6.4 Design Criteria

- On slope applications should be installed on contour.
- Are appropriate for emergency materials
- See Table 3-7 Barrier spacing for general application.
- Ends of bags must be tightly abutted and overlapped to direct flow away from bag joints.

3.4.5.6.5 Maintenance

- Inspect sandbag installations after storms. Check that ends of bags are tightly abutted. Check that undercutting or end-flow is not occurring.
- Check that flow is not becoming channeled behind bags (parallel to row of bags).
- Remove sediment accumulated behind bags when sediment reaches one-third of the barrier height.
- Replace damaged bags as needed.

3.4.5.6.6 Common Failures

- Not being tightly abutted together, which allows flow between or under the bags causing rilling.
- Another common failure is caused when the bags are not installed on contour and water flow becomes channeled behind the bags.
- Sanbags are sometimes not removed after site is stabilized.
- Sandbags can also be dislodged when placed in high velocity flows, or when struck by construction equipment or other vehicles.

3.4.5.7 Brush Barrier – Sediment Barrier Type 5

A brush barrier is a rarely used temporary sediment barrier constructed at the perimeter of a disturbed area using materials available from clearing and grubbing of the site. The barrier intercepts and retains sediments that are washed from disturbed areas. Brush Barrier detail is provided in Standard drawing [RD1031](#).

Applications

- On gently sloped areas.
- Disturbed areas draining less than $\frac{1}{4}$ acre, where runoff is primarily sheet and rill erosion.
- Residual materials are available onsite for barrier construction.



Figure 3-24 Novel brush barrier (brush wattles) Installation in Germany

3.4.5.7.1 Advantages

- Saves material costs by utilizing materials onsite, but labor intensive to build.
- Reduces velocity and quantity of runoff.
- Fully biodegradable and can remain in place unless geotextile is used.

3.4.5.7.2 Disadvantages

- Only effective if erosion and sediment are controlled elsewhere onsite.
- Suitable for only a limited drainage area.
- Has limited life span.
- Labor cost to assemble brush barriers is more than with purchased BMPs.

3.4.5.7.3 Design Criteria

- The height as shown in Std Drg is shown as being between 3-3/4 – 5 ft. Functional brush barriers can vary in size.
- See Table 3-7 Barrier spacing for general application.
- The width as shown in Std Drg is shown as being between 5 ft. – 15 ft.
- Filter fabric anchored over the barrier can enhance the filtration capacity and effectiveness of the barrier.
- Fill barrier with 6 in. maximum diameter woody debris or topsoil strippings.

3.4.5.7.4 Maintenance

- Generally require little maintenance.
- Heavy buildup of sediment on the upslope side of the barrier should be removed when sediment reaches one-third of the barrier height.
- The barrier fabric (if used) should be inspected occasionally for tears and repaired as necessary.
- When the barrier is no longer needed, the fabric must be removed to allow natural establishment of vegetation within the barrier.

3.4.5.7.5 Common Failures

Failures most commonly result from loose construction, allowing water to easily pass through the vegetation. Improperly installed filter fabric can also be a problem.

3.4.5.8 Aggregate Sediment Barrier Type 6

Aggregate barrier is an infrequently used temporary sediment barrier. The barrier intercepts and retains sediments that are washed from disturbed areas.

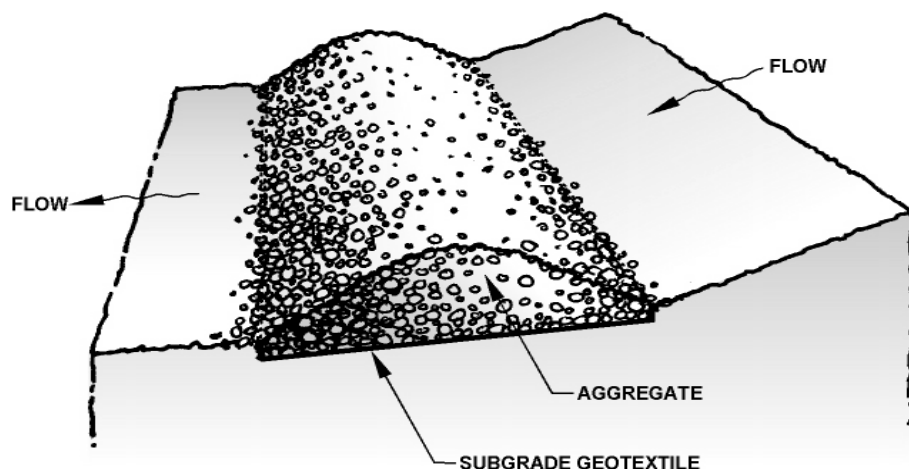


Figure 3-25 Aggregate Barrier Type 6 Retains sediment in aggregate berm.

- Refer to detail: [RD1031](#) Sediment Barrier (Type 6), located on the ODOT web page on the Engineering Standards page in the [Roadway Section](#).

3.4.5.8.1 Applications

- In traffic areas on construction sites.
- On gently sloped areas.
- At staging areas, stockpile sites or disposal sites.
- Along roadway edges to dissipate sheet flow.

3.4.5.8.2 Advantages

- Very efficient method for sediment removal.
- Reduces runoff velocity.
- Uses common material
- Long lasting BMP

3.4.5.8.3 Disadvantages

- More expensive than some other measures because it requires clean gravel or crushed rock rather than materials found onsite.
- Clogging from mud and soil may make maintenance difficult.

3.4.5.8.4 Design Criteria

- Use 2 in. maximum washed and well-graded aggregate 4"-1" with less than 5% fines.
 - Height and side slopes: 2 ft. high with 1:3 side slopes.
 - See Table 3-7 Barrier spacing for general application.

3.4.5.8.5 Maintenance

- Remove and replace gravel when filtering capacity is reduced by half to maintain performance.
- Removed sediment accumulation when it reaches one-third of the barrier height.

3.4.5.9 Pre-Fabricated Barrier System – Sediment Barrier Type 7

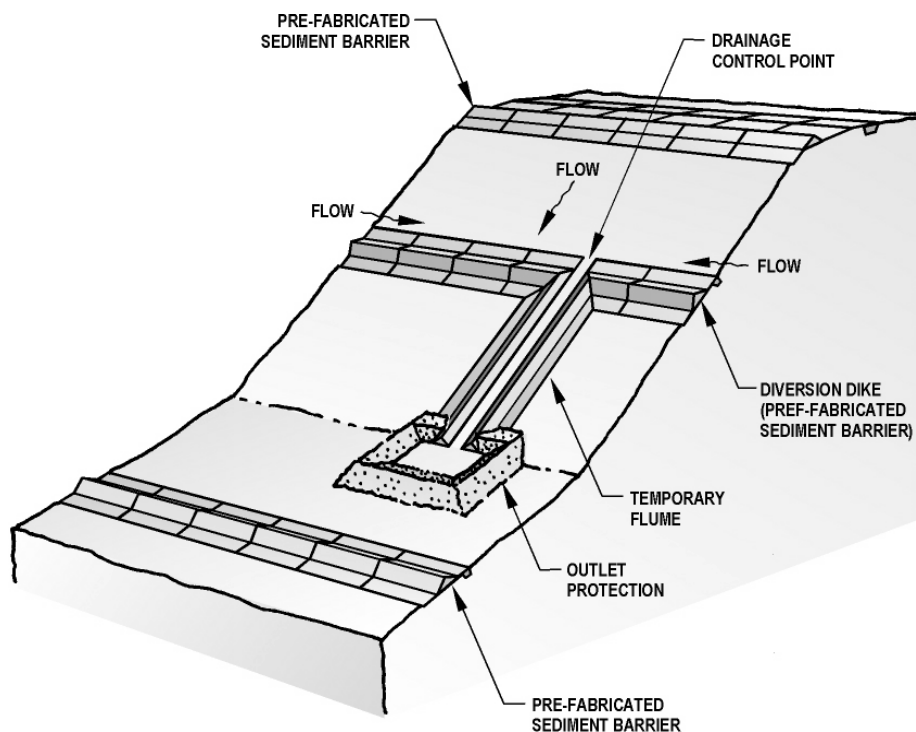


Figure 3-26 Pre-fabricated Barrier System – Sediment Barrier Type 7

Pre-fabricated barrier systems typically consist geotextile fabric surrounding a flexible material usually foam or other flexible, lightweight material. The geotextile extends from the bottom of the barrier to provide flaps or aprons on the upslope and downslope sides of the product. The prefabricated system is anchored by and stapling the aprons, or when used on pavement weighting the aprons down with sand bags. Barrier materials, section lengths and weights vary among manufacturers.

- If using a pre-fabricated barrier system, install in strict compliance with manufacturer's recommendations

3.4.5.9.1 Applications

- To capture and retain sediment on slopes.
- To shorten slope length

- To capture runoff from top of slopes or at intermediate locations on slopes and direct water to a suitable conveyance or exit point.
- As sediment barrier on pavement or to direct surface drainage on pavement.
- Diversion dike.
- Check dam.
- Emergency Material

3.4.5.9.2 Advantages

- Lightweight.
- Installation is relatively simple.
- Can be used to divert and slow velocities of small flows.
- Conforms to curves and rough terrain.
- Durable and some products are capable of being driven over by light vehicles
- Reusable.

3.4.5.9.3 Disadvantages

- Effective for unknown period of time (depends on material properties).
- Not effective in steep swales, channels or ditches.
- If improperly installed can allow undercutting or end-flow.
- Not effective where water velocities or volumes are high.
- Installation must be done exactly as specified by manufacturer.
- May be difficult to install on steep slopes.
- Can be damaged during sediment removal operations.

3.4.5.9.4 Design Criteria

- On slope applications should be installed on contour.
- Install in accordance with plans, special provisions and manufacturer's recommendations.
- See Table 3-7 Barrier spacing for general application.

3.4.5.9.5 Maintenance

- Inspect pre-fabricated barriers after storms. Check that undercutting or end-flow is not occurring.
- Check that barrier is not otherwise damaged.
- Check that aprons are securely anchored.
- Check that flow is not becoming channeled behind barrier (parallel to barrier).
- Remove sediment accumulation behind barrier when sediment reaches one-third the barrier height.
- Replace damaged sections as needed.

3.4.5.9.6 Common Failures

- Failures most commonly result from:
- Improper installation (not anchoring the aprons correctly) which allows flow under or around the barrier.
- Physical damage or displacement resulting from being run over by vehicles or equipment

3.4.6 Sediment Fence



Figure 3-27 Sediment fence is trenched in correctly

Temporary sediment barrier consisting of geotextile fabric stretched across and attached to supporting posts. Sediment fences are adequate to treat flow depths consistent with overland or sheet flow. Correctly installed sediment fences can retain large volumes of sediment and are robust BMPs. Sediment fence is generally not the correct material for boundary delineation. Orange colored sediment fence may serve as boundary delineation where a sediment barrier is appropriate, where the boundary is level, and the BMP to be installed on contour as specified for the sediment control BMP. Sediment fence is not the correct BMP to divert surface flow from above disturbed ground.

Sediment fence fabric must comply with Section 02320-3. Refer to Section 00280 for more specific information.

When planning for the use of sediment barriers, consider that many products are effective sediment barriers that do not have the disadvantages of sediment fence.

- Refer to detail: [RD1040](#) Sediment Fence located on the ODOT web page on the Engineering Standards page in the [Roadway Section](#).

Applications

- Sediment fences can be used as the sole treatment when the area draining to the fence is less than $\frac{3}{4}$ acre per 300 ft. of sediment fence and the average slope (perpendicular to the fence) is 1:3 or flatter. Otherwise, use sediment fence in conjunction with other measures such as erosion prevention.
- Sediment fence is viable perimeter control downslope of disturbed ground. Use in conjunction with other BMPs such as erosion prevention and runoff control.
- Sediment fence can be used on slopes flatter than 1V:2H.
- Install downslope of disturbed areas and prior to upslope clearing and grading.
- Do not use sediment fences in v-ditches or streams.
- Sediment fence can be configured as inlet protection around field inlets

Advantages

- Reduces runoff velocity.
- Generally a robust sediment control measure
- Can retain large volume of sediment
- Relatively inexpensive.
- Familiar BMP that is readily available

Disadvantages

- Applicable to small drainage areas and overland flow; not applicable to concentrated flows.
- Incorrect installation renders BMP ineffective.
- Difficult to embed on compacted or rocky ground.
- Requires frequent maintenance and inspection.
- Easily damaged if struck by rolling rocks during embankment construction
- Must be removed (but often is not) once vegetative stabilization is achieved.
- Removal of sediment fence causes minor soil disturbance that must be addressed.
- Removal of sediment fence can compromise vegetative stabilization.
- Must be disposed of after single use, adding to the waste stream



Figure 3-28 Sediment fence should be removed once vegetation is established

Design Criteria

- The height of a sediment fence should not exceed 3 ft. Storage height and ponding height should never exceed 20 in.
- Sediment fence is typically supplied with marks on the fabric to provide guidance on the correct depth of embedment.
- Sediment fence without sewn in sleeves are installed with supporting posts down slope of fabric.
- Sediment fence with sewn in sleeves are correctly installed with sleeves upslope (putting the post on the down slope side of the fabric).
- Design and install sediment fence level and along ground contours.
- When sediment fence approaches a ditch or swale, end the fence on each side of the ditch or swale and install a check dam in the ditch or swale.
- If possible, the filter fabric should be cut from a continuous roll to avoid the use of joints. When joints are necessary, filter cloth should be spliced only at a support post, with a minimum 4 ft. overlap and both ends securely fastened to the post, or join the two end stakes by wrapping the two ends at least one and one-half turns and driving the joined stakes into the ground together.
- Posts should be spaced a maximum of 6 ft. apart and driven securely into the ground (minimum of 10 in.).
- Turn the ends of the sediment fence uphill.
- A trench should be excavated approximately 6 in. deep along the line of the posts and upslope from the barrier in which to embed the fabric.
- To facilitate installation on rocky ground bottom flap can be folded upslope and covered with 12 inches of aggregate or soil to prevent water from piping under fabric
- The filter fabric shall be stapled or wired to the posts if not pre-fitted with sleeves, and the bottom 6 in. of the fabric should extend into the trench.
- The trench should be backfilled and the soil compacted over the bottom flap of the filter fabric. Sediment fences placed at the toe of a slope should be set at least 6 ft. from the grade break in order to increase ponding volume.

Maintenance

- Inspect fences weekly and after each storm event. Immediately repair any damage.
- Remove accumulated sediment once it has reached 1/3 the height of the sediment fence or 1 ft. maximum.

- Inspect for channel formation parallel to the fence, which indicates the sediment fence is not installed on contour or it is acting as a flow barrier.
- Replace deteriorated or clogged geotextile.
- Check for undercutting or piping under fence.
- At base of embankment slope, replace or repair sediment fence that has been damaged by rocks rolling down slope



Figure 3-29 Sediment fence maintenance failure

Common Failures

Common problems with sediment fence are:

- Inadequate installation such as;
 - Fence posts are not driven deep enough
 - Fabric is not trenched in at least 6 in
 - Poor compaction of backfill material in trench
 - Sediment fence is installed in areas where concentrated flow occurs
 - When not installed along contour.
 - When ends of fence runs are not turned upslope.
 - When used in flood prone areas sediment fence can become fish trap
- When used at top of slope to divert off-site runoff flow can cut channels against geotextile fabric. (use interceptor dike/swale)
- Wrong material to use as boundary delineation
- When used at bottom of slope, rocks rolling down slope will damage sediment fence.
- When used as an intermediate sediment barrier, mid-slope, low permeability of the geotextile fabric results in impounded water that can over-saturate soil causing a shallow planar slide.



Figure 3-30 Sediment fence not embedded in ground

- Commonly not removed as required in Section 00280.70

3.4.7 Inlet Protection

Generally, inlet protection prevents coarse sediment from entering storm drainage systems by filtering runoff and retaining sediment before it reaches a drainage inlet or storm sewer system. There are many options and variations of inlet protection available. The marketplace is frequently introducing new inlet protection products to industry to address the multiple configurations of inlets. Designers should be familiar with new products and the best current thinking.

- Refer to detail: [RD1010](#) which shows 6 types of Inlet Protection
 - Type 2 – Geotextile/Wire Mesh & Aggregate
 - Type 3 – Prefabricated filter insert
 - Type 6 – Sod protection
 - Type 7 – Compost filter sock
 - Type 10 – Curb inlet sediment dam
 - Type 11 – Wattle barrier with filter insert.
- Refer to detail: [RD1015](#) Inlet Protection (Type 4) Biofilter bags.

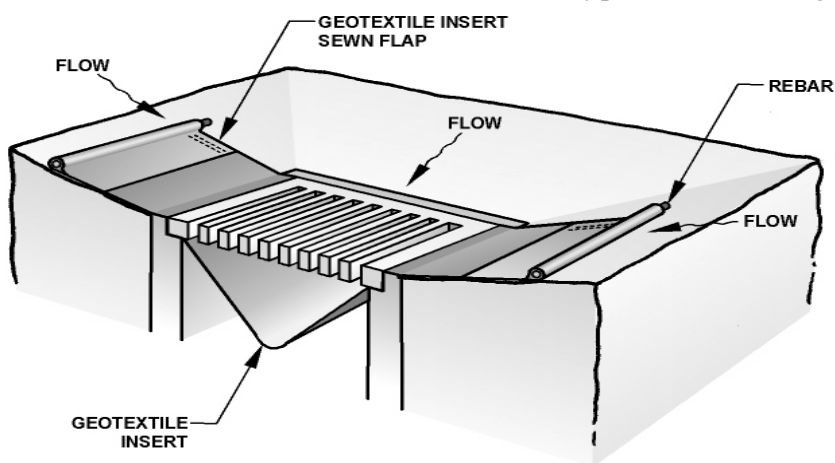


Figure 3-31 Inlet Protection – Geotextile Filter Fabric Insert (Type 3)

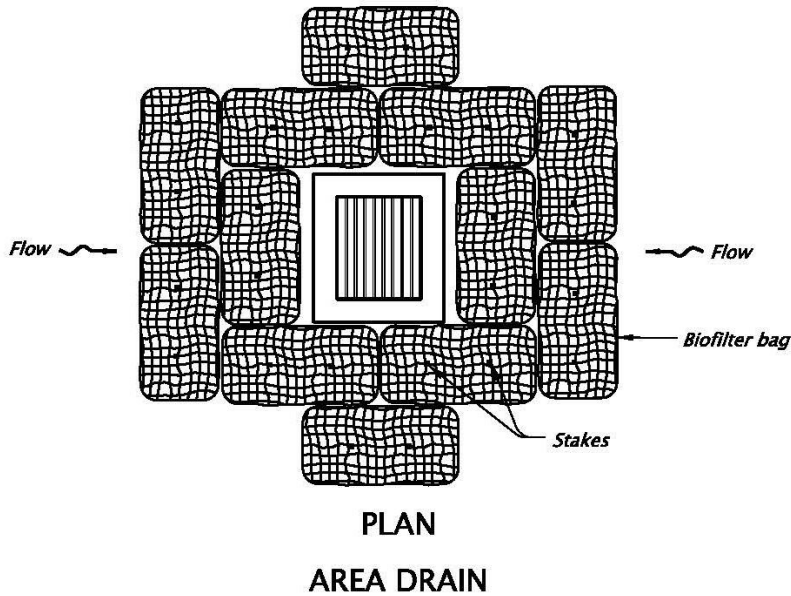


Figure 3-32 Inlet Protection – Biofilter Bags (Type 4)

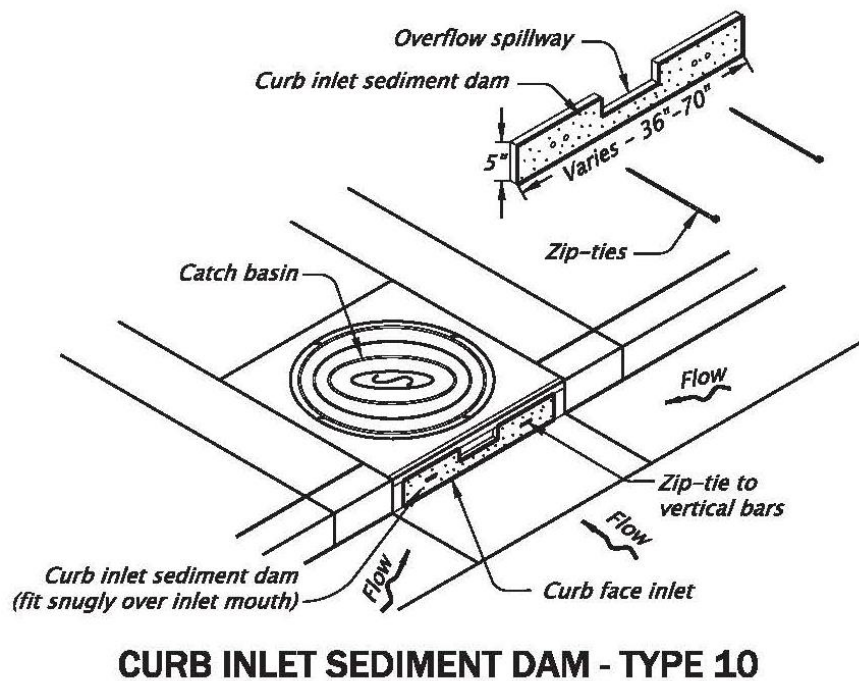


Figure 3-33 Inlet Protection – Curb Inlet Sediment Dam (Type 10)

Applications

- All inlets which are capable of receiving stormwater runoff off of exposed soil or areas adjacent to construction sites where potential of sediment-laden water exists.

- At storm drain inlets downslope and within 500 ft. of a disturbed area or construction entrance.
- As a secondary measure downstream from erosion prevention and sediment trapping measures.

Advantages

- Prevents sediment from entering the storm drain system.
- Reduces amount of sediment leaving the site.

Disadvantages

- May result in ponding of water above the catch basin. Ponding that extends to active roadways must not be allowed to occur.
- Sediment removal may be difficult under high-flow conditions. Perform maintenance as ongoing procedure and before anticipated rain events.
- If struck by vehicle compost socks (Type 7) or biofilter bags (Type 4) are easily dislodged or damaged, rendering them ineffective and requiring maintenance. Surface mounted inlet protections, such as compost socks (Type 7) or biofilter bags (Type 4) can be a traffic hazard that can cause injury if struck by bicyclist or motorcyclist.
- Short-circuiting of flow may occur if not properly installed.
- Improper installation, maintenance or removal may introduce sediment into the storm drain system.

Design Criteria

- When protecting area drains, place inlet protection in areas where water can pond, and where ponding will not have adverse impacts.
- Inlet protection must allow for overflow in a severe storm event.
- Inlet protection types include:
 - Type 2 Geotextile with Aggregate Filter – Functional but rarely used
 - Type 3 Catch Basin Insert – easy to install & remove. No impediment to traffic. Usually constructed with high flow overflow. This BMP is installed under inlet grates and is easily overlooked during inspections, maintenance and when they are supposed to be removed.
 - Type 4 Biofilter Bags – This BMP is appropriate for use around field inlets and area drains. When installed on pavement per the standard drawing, there is a likelihood that biofilter bags will be struck by vehicle and dislodged and/or broken, spilling contents. An accident can result if a bicyclist or motorcyclist strikes a biofilter bag used as inlet protection on active pavement.
 - Type 6 Sod – This BMP slows velocity and filters sediment out of runoff.
 - Type 7 – Compost Filter Sock or Wattle – This type of inlet protection is most appropriate for field inlet or area drain applications surrounded by soil. Compost sock has significant mass and will conform to ground with no embedment. When used on

inlets in active pavement there is a high likelihood they may be struck by vehicles and dislodged or broken. An accident can result if a bicyclist or motorcyclist strikes a compost sock or a straw wattle used as inlet protection on active pavement.

- Type 10 – Curb Inlet Sediment Dam – This inlet protection consists of filter material that is fixed to the opening of inlets with the opening in the curb face. By themselves, these are not effective for inlets that combine horizontal grates with the curb face inlets and may need Type 3 inlet protection as well (similar to standard drawing for Type 11).
- Type 11 – Wattle Barrier combined with Type 3 Filter Insert. – Inlets that combine curb face inlets with horizontal grates require hybrid or combination inlet protection.
- Inlet protection types have recently been introduced that consist of different types of prefabricated filters suitable for different types of inlets. These are made to protect configurations including area drains, trench drains and curb face inlets. These newer products can be less labor intensive than more familiar BMPs and they may be approved for use by Construction PM or technical expert.
- Sediment Fence – Using field fabrication, sediment fence can be used to protect area drains surrounded by soil. Note that sediment fence fabric has low permeability and will impound water. This type of inlet protection is not supported by a standard drawing
- Masonry & Aggregate – This inlet protection BMP is labor intensive to install, difficult to maintain and is not supported by standard drawings and not recommended for use.
- * Where inlets combine curb face and grate inlets, these inlet protections are used in combination

The industries that make products for erosion and sediment control are constantly coming up with new products. These products might be improvements on existing designs or designs that address inlet types that are not otherwise addressed. ODOT is generous in granting conditional approval on a project-by-project basis for products that are not on the Qualified Products List (QPL). It is desirable for ODOT to use the most appropriate BMPs on its projects, so designers should stay informed and be aware of products that best address a project's need.

INLET TYPE & SITE CONDITIONS		Area drain - soil	Area drain - Pavement	Ditch Inlet - soil	Ditch Inlet - Pavement	Grate Inlet Along Curb - Soil	Grate Inlet along Curb - Pavement	Curb Opening Inlet - Pavement	Curb Opening & Grate Inlet - Pavement
I N L F	2	Y	Y	N	N	Y	Y	N	N

INLET TYPE & SITE CONDITIONS			Area drain - soil	Area drain - Pavement	Ditch Inlet - soil	Ditch Inlet - Pavement	Grate Inlet Along Curb - Soil	Grate Inlet along Curb - Pavement	Curb Opening Inlet - Pavement	Curb Opening & Grate Inlet - Pavement
	3		Y	Y	N	N	Y	Y	N	Y*
4		Y	Y	Y	Y	Y	Y	Y	Y	
6		Y	N	Y	N	Y	N	N	N	
7		Y	Y	Y	Y	Y	Y	Y	Y*	
10		N	N	N	N	N	N	Y	Y*	
11		N	N	N	N	N	N	N	Y	

*Where inlets combine curb face and grate inlets, these inlet protections are used in combination

Table 3-8 Inlet protection selection based on site conditions

Maintenance

- Inspect each inlet protection during routine monitoring and after each rain event of 1/2 inch or more.
- Replacement of Type 3 inlet inserts may be more efficient than removing captured sediment
- If the Type 2 aggregate becomes clogged with sediment, it must be carefully removed from the inlet and either cleaned or replaced.
- Assess the impacts of allowing water to pond at the inlet (not acceptable on active roadways) and provide an overflow weir or some other type of relief.
- If Type 4 or Type 7 inlet protection is damaged or displaced (by vehicles or equipment), repair or replace that inlet protection.
- Consider the effect of placing obstructions at inlets on grade may have on their hydraulic efficiency. Refer to the ODOT Hydraulics Manual or contact the Geo-Environmental Unit when placing protection at several inlets on grade along a roadway section.
- Do not use water to clean inlet and do not flush sediment into inlet.
- Remove sediment from inlet protection when it has reached 50% of its capacity.
- Repair or replace materials as needed to ensure proper functioning.

Common Failures

- The most common problems with this BMP include:
- Torn geotextile material
- Improperly sealed gaps between inlet protection and the inlet structure
- Maintenance not conducted.
- Vehicle strikes on biofilter bags, wattles or compost socks that displace the BMP or break open the BMP spilling contents
- On active roadways, motorcycle or bicycle strikes on biofilter bags, wattles or compost socks that may cause rider to fall.
- Inlet protection not removed after site is stabilized.

3.4.8 Sediment Trap

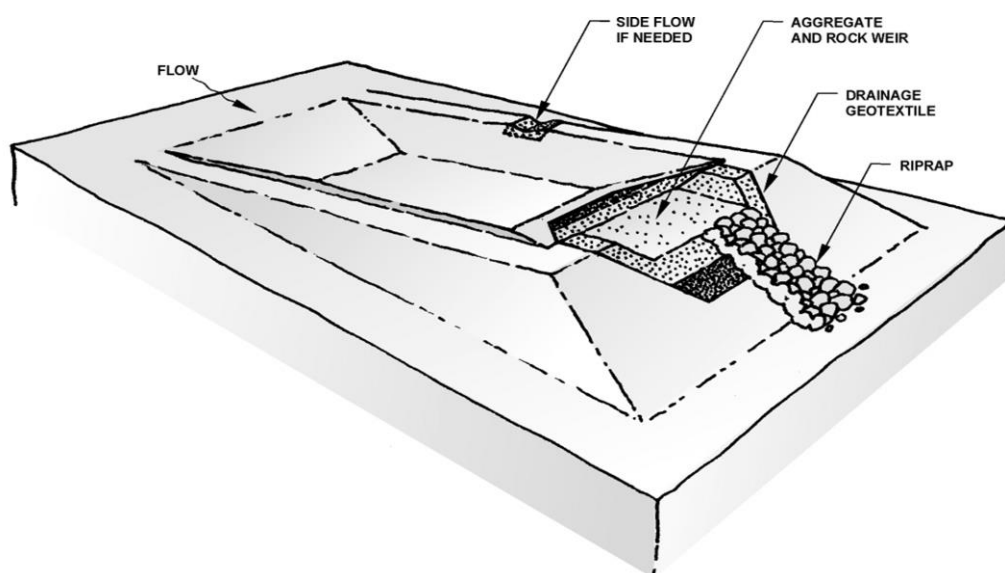


Figure 3-34 Sediment Trap

A sediment trap consists of a small, temporary ponding area, any appropriately sized basin with stabilized outlet can function as a sediment trap. The sediment trap serves drainage areas 5 acres and smaller and has a design life of approximately six months. Sediment traps must be designed for a 2 year/24 hour storm event or in conjunction with other BMPs to provide equivalent detention and treatment as a sediment trap designed for a 2 year/24 hour storm. Calculations for sediment trap sizing must be provided when requested by regulatory Agency.

- Refer to the Standard Detail: [RD1065](#) Sediment Trap, located at the end of this section. Also, refer to Sediment Trap Sizing.

Applications

- Drainage areas that are 5 acres and smaller.
- Sites in proximity to salmonid streams, wetlands, or phosphorus-sensitive water bodies.
- Sites where major clearing and grading is likely to occur during the wet season.
- Sites with downstream erosion or sedimentation problems.
- Downslope of disturbed areas.
- To capture runoff from areas where soils are amended with cementaceous material.

Combining with Permanent Drainage Facilities

- If a project includes a permanent storm water retention/detention pond, the rough-graded or final-graded facility could function as a trap during construction. Design features of the permanent structure, such as surface area, retention time and outlet control, should meet the design requirements of the temporary facility. Completion of the permanent facility should occur only when all upstream control structures are in place and permanent vegetative stabilization of contributing drainage areas is complete.
- If a project includes a permanent detention/infiltration facility, the roughly excavated facility could be used as a trap or basin providing the facility provides the surface area and retention time required by the trap or basin. When temporary facility is converted to permanent use, excavate the sides and bottom of the facility to a minimum of 2 ft. below final grade to remove settled fine sediment with a backhoe working at “arm’s length” to minimize disturbance and compaction of the infiltration surface. Install free draining soil or blended treatment media to bring basin to finish grades.
- Additionally, any required pretreatment facilities should be fully constructed prior to any release of sediment-laden water to the facility. Pretreatment and shallow excavations are intended to prevent the clogging of soil with fines.

Advantages

- Protect downstream riparian areas from sediment deposits.
- Prevent reduced downstream capacity due to sediment deposition in a stream channel.
- Prevents clogging of downstream facilities.
- Removes particles up to medium silt size (0.02 mm).
- Surface water conveyances can be connected to the facility as site development proceeds. The designer may want to route surface water collected from disturbed areas of the site through a sediment trap prior to release from the site.

Disadvantages

- May become an attractive nuisance. Care must be taken to adhere to all safety practices.
- Maintenance and sediment removal is essential for adequate performance.

- Serves limited areas.
- Does not reduce turbidity resulting from fine silts and clays in runoff. Traps are more effective when used in conjunction with other measures such as flocculent treatment. Erosion prevention such as seeding and mulching reduces the turbidity of water entering the trap.

Design Criteria

- Sediment trap design drawings must be stamped and signed by licensed engineer.
- Design sediment trap to detain runoff from 2 year 24 hour storm of 3600 Cu. Ft.
- Undersize sediment traps are allowed when used in combination with other BMPs.
- Drainage of sediment must be drawn from water's surface.
- Construct prior to any upslope clearing and grading.
- Locate in a low area where the trap will intercept all or most of the runoff from the disturbed area before it enters a waterway, considering safety in case structure fails.
- Locate the trap so that it is readily accessible for maintenance.
- Provide for diversion dikes and ditches, as needed, to collect and divert water toward the trap.
- Design the trap with a level bottom, 1:3 or flatter side slopes and a L:W ratio of 3. Because sediment traps are temporary, the sizing is less important to proper functioning than is constant maintenance.
- Construct the trap as the first step in the clearing and grading of the site.
- Form the trap by excavation or by construction of compacted embankment. If the trap is formed by embankment, the designer should note that dam safety regulation may apply to heights exceeding 5 ft. The embankment should be stabilized using a cover method such as seeding, mulching, plastic sheeting or erosion control matting.
- Use floating skimmer drain inlets to remove least turbid water from surface water of sediment trap.
- Do not drain traps directly into a stream, lake or other waterway. Water temperature in the trap may be too high for direct release. Always moderate the water temperature before it drains into a lake, stream, wetland or waterway. Whenever possible, release the trap discharge onsite onto a relatively level, densely grassed area at least 60 ft. from a waterway or wetland.
- Evaluate the release areas on a site-by-site basis in order to determine appropriate locations for and methods of releasing runoff. Do not use vegetated wetlands for this purpose. Refer to the [ODOT Hydraulics Manual](#) for design guidance on culverts and channels.

Maintenance

- Constant maintenance is essential for proper functioning.
- Remove sediment from the trap when it reaches one-third the storage capacity.
- Repair any damage to the trap, the embankments or the slopes.

Common Failures

Most sediment trap failures are related to poor location, incorrect sizing, and poor maintenance. If sediment is not removed from the trap on a regular basis, the sediment trap may become a source of sediment pollution during large rain events.

3.4.9 Flocculent Treatment



Passive Water Quality Treatment Swale:

Chitosan sleeve is installed in upstream cell of chambered treatment swale. Flocculent binds suspended sediments into larger aggregates that can be filtered or fall out of suspension in the still-water chambers.

Figure 3-35 Passive Water Quality Treatment Swale

When used in sediment control a flocculent is a clarifying agent. Flocculants as approved for use on ODOT projects is naturally occurring long chain polymers that consist of crushed crab and shrimp shells called chitosan. The flocculent is enclosed in a pervious sleeve and when turbid water is processed through the sleeve the sediments in liquid suspension aggregate together and gain size and mass so that they can fall out of suspension or be filtered. Flocculants can be used in passive treatment facilities that depend on gravity to move water over flocculent treatment and through filters or basins to remove or settle out sediment, such as the treatment swales shown in photos. After turbid water flows over/through the flocculent sock the water must be provided with settling pools, check dam arrays or filters to address the aggregated sediment.

Flocculants can also be used in active treatment facilities, like Baker Tanks, where pumps are used to move the water and filters capture the aggregated sediments. When active treatment systems are used, the system design must be stamped and signed by professional engineer and assurances provided that system will have no negative impact on receiving waters or aquatic organisms. Turn-key system providers will have signing engineers. Active treatment systems must have

settlement or filtration provided for the flocculent treatment to function. When treatment systems using tanks, pumps and filters, comply with system manufacturer's recommendations for operation and monitoring of system. Operators of flocculent treatment systems are required to be qualified in their use and operation.

3.4.10 Temporary Settling Tanks

Temporary settling tanks are commonly known as Baker tanks or Rain For Rent tanks. These are active treatment facilities that detain, treat and release treated water.



Array of Baker Tanks provide treatment to settle out the sediment, storage and filtration to ensure discharged water is clear.

Figure 3-36 Array of Baker Tanks

Applications

- Projects with little available land on which to provide other treatments.
- In Temporary Settling Tanks where treatment is accelerated with the use of pumps and filters.
- Sites in proximity to salmonid streams, wetlands,
- Sites where major clearing and grading is likely to occur during the wet season.
- Sites with downstream sedimentation problems.

Advantages

- Because pumps are used, tanks do not need to be located at project low points.
- Protect downstream riparian properties from sediment deposits.
- Prevents clogging of downstream facilities.
- Remove particles up to medium silt size (0.02 mm).
- Treatment can address different types of water pollutants
- Surface water conveyances can be connected to the facility as site development proceeds.

- Proven and predictable results.

Disadvantages

- Require power source to operate pumps.
- A relatively expensive BMP
- Maintenance and sediment removal are essential for adequate performance.
- Must be operated by experienced technician.
- Treatment media gets used up over time and must be replaced.

Design Criteria

- Active system is assembled at project site. Tanks, pumps and plumbing are sized as project criteria require.
- Active systems using pumps, tanks and filters are calibrated to meter the flocculent accurately. Use all components in the system per manufacturer's recommendations
- Active treatment systems must be stamped and signed by professional engineer
- Active systems must be operated by qualified personnel.
- Outfall must discharge into a scour hole or energy dissipater.

Maintenance

- Inspect weekly and after each rain.
- Replace treatment media as necessary.
- Remove sediment when the sediment storage capacity is half-full.

Common Failures

Most failures with flocculent treatment are:

- Electricity outage
- Inadequate maintenance
- Depleted filter media are not replaced.

Chapter 4 - POLLUTION CONTROL MEASURES AND BMP'S

4.1 Management of Other Construction Site Pollutants

There are numerous potential pollutants other than sediment associated with construction activities. Potential pollutants include those associated with the use of concrete and other cement-related mortars. Standard Drawing RD1070 in the catalog of erosion and sediment control BMPs includes a simple concrete washout. Other concerns and pollutants are the handling, application, and disposal of construction products and chemicals such as paints, adhesives, and solvents. The improper use and handling of construction materials can result in wash water, spills or wastes being left on the ground. These chemicals can infiltrate into soils causing groundwater contamination or wash off to surface waters during storms. Proper handling of these materials is included in the permit requirements making violations punishable by law.

The ESCP designer is required to provide an Environmental Management Plan (EMP) with the ESCP for projects that potentially contain, use or expose contaminants or pollution sources. The EMP describes the control of contaminated material. The EMP must be provided to Oregon Department of Environmental Quality (DEQ) with fee, prior to beginning construction. The requirements for the EMP are provided with the [1200-CA Appendix A](#).



Figure 4-1 Petroleum products are a common pollutant

The contractor is required to develop a Pollution Control Plan (PCP) on all projects as required by Standard Specification Section 00290.30. Although this manual is not intended to address all aspects of construction site pollution control, some issues overlap with erosion and sediment control and must be taken into account in the overall planning process. At a minimum, the contractor should provide pollution prevention for 1) off-site tracking of soils, 2) material management, 3) waste management, and 4) vehicle and equipment management. Also, [Technical Advisory GE12-01\(A\)](#) provides guidance allowing diminished reliance on the 00280 Section of the Specifications for small projects. For those projects that qualify for the simplified (or eliminated) Erosion and Sediment Control Section, 00280, the Environmental Protection required in the 00290 Section becomes more important. The PCP should also include erosion

and sediment control for contractor activities that are not addressed in the ESCP, including in-water work activities and on-site or off-site activities related to the project.

Each construction project is unique, and understanding the pollution risks for each construction activity is essential to successfully selecting and implementing pollution control BMP's. Defining these risks requires careful review of the site characteristics and the nature of the construction project. Once risks are defined, BMP objectives can be developed and pollution control BMP's selected. In general, the pollution control BMP objectives for construction projects are as follows:

- Practice Good Housekeeping – Perform activities in a manner which keeps potential pollutants from either draining or being transported off-site by managing pollutant sources and modifying construction activities.
- Contain Waste – Dispose of all construction waste in designated areas and keep storm water from flowing on or off of these areas.

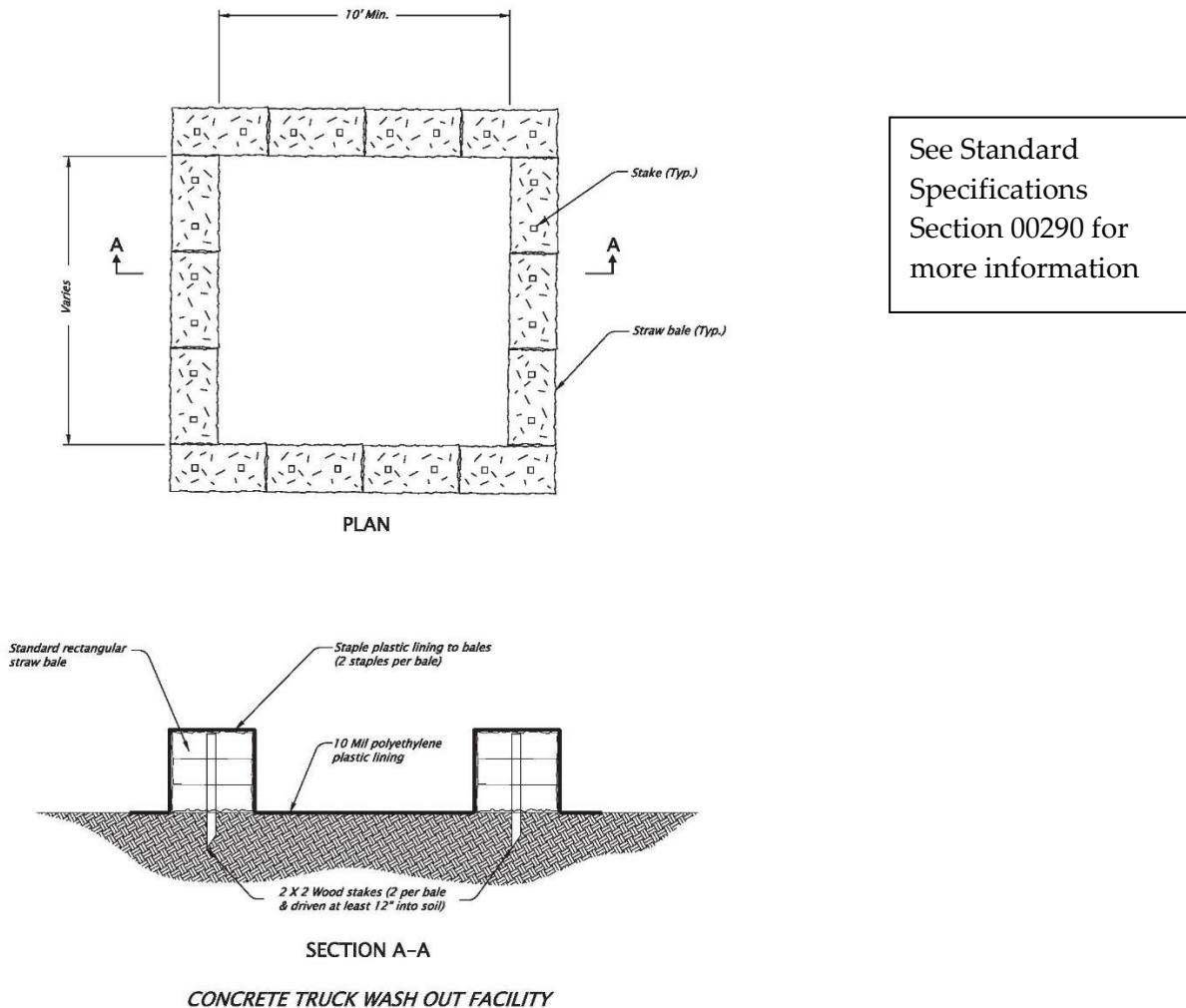


Figure 4-2 Concrete Washout - Standard Drawing RD01070

4.2 ENVIRONMENTAL MANAGEMENT PLAN

The 2022 1200-CA Permit update requires Erosion and Sediment Control Plans include an Environmental Management Plan (EMP) for projects that will or have the potential of encountering contaminated soils, contaminated groundwater, or hazardous materials during construction, or that use an active chemical treatment system.

A detailed Contaminated Media Management Plan (CMMP) describing the concentration, location and depth of contamination will need to be provided as it is described in the [1200-CA Permit's Appendix A](#). Also Best Management Practices on pollution prevention and treatment proposed to control the discharge of stormwater that has been impacted by contaminated soil, groundwater or hazardous materials must be provided.

Chapter 5 - EROSION and SEDIMENT CONTROL PLANNING

The purpose of erosion and sediment control planning is to predict areas that are at risk of erosion, to predict where stormwater runoff will flow and to predict locations where erosion and sediment control can be most effective. This planning should establish clearly which control measures are likely to be most successful to prevent erosion and off-site sedimentation during construction. The Erosion and Sediment Control Plan (ESCP) serves as a blueprint for the location, installation, and maintenance of practices to control erosion and prevent sediment from leaving the site during construction.

Sections 1 and 2 of this chapter discuss planning issues relevant to designers, contractors and inspectors, including:

- Site information
- Data collection
- Types of construction
- Erosion prevention vs. sediment control
- Assessing the project site
- 5 basic rules
- Project scheduling
- Site characteristics

Chapter 6 discusses the ODOT ESCP design process. Chapter 6 will be of interest primarily to designers, however, much of the information included is useful to persons involved in ESCP implementation.

5.1 Site Information

An erosion and sediment control plan must contain sufficient information to describe the site development and the system of multiple BMPs intended to control erosion and prevent permit violations and off-site damage from sedimentation. The [1200-CA permit](#) (provided in this document's Appendix A) lists information that is required to be on the ESCP. Required with the ESCP is an ESCP Cover Sheet where much of the site information will be displayed. Cover sheet information is formatted to provide DEQ, the regulatory agency, an overview of the project with details relevant to their oversight. ODOT provides a [Cover Sheet template](#) on the Erosion and Sediment Control web site, under Guidance Materials. That information is categorized under the following headings:

- Site Description – As many as 40 types of site information are required.
- Site Map – Provide on Project coversheet and ESCP Cover Sheet
- Required Control Practices – Shown on ESCP and noted on ESCP Cover Sheet and detailed in Special Provisions.

- Additional Control Practices – Shown on ESCP and detailed in Special Provisions

5.2 Data Collection

The base map for the Agency ESCP is prepared from a detailed topographic map, usually developed by Agency surveyors and included in the directory of project files. A soils map should be obtained from the local office at the USDA [Natural Resource Conservation Service](#). Transferring soil survey information to the topographic map is helpful for site evaluation, however listing soil types on ESCP Cover Sheet is acceptable.

The design engineer, landscape architect or erosion and sediment control specialist responsible for the plan should inspect the site to verify the base map with respect to natural drainage patterns, drainage areas, general soil characteristics, and off-site factors. The base map should reflect such characteristics as:

- Soil types.
- Existing drainage patterns.
- Proposed drainage patterns.
- Water bodies with Ordinary High Water Elevations (OHWE).
- Watershed areas.
- Existing vegetation, noting special vegetative considerations such as high value habitats.
- Regulated areas such as wetlands, water bodies, or riparian corridors.
- Areas that are critical habitat for regulated or listed plant or animal species. Areas directly adjacent to critical habitat for regulated or listed plant or animal species.
- Critical areas such as steep slopes, eroding areas, rock outcroppings, and seepage zones.
- Critical or highly erodible soils that should be left undisturbed.
- In the analysis of these data, identify:
 - Buffer zones.
 - Suitable stream crossing areas.
 - Borrow and waste disposal areas.
 - Stockpile and staging areas.
 - Access routes for construction and maintenance of erosion and sediment control devices.
 - The most practicable sites for control practices.

5.3 Types of Construction

ODOT construction projects may include new roadway alignments, shoulders, lanes, drainage improvements, bridges, culverts, retaining walls and soundwalls, structure widening, paving and pavement replacement. Other activities may include the reconstruction of interchanges, retrofitting of bridges, culverts, channel improvements, landslide stabilization, and the protection of environmentally sensitive areas. ODOT also constructs wetlands, uplands, grasslands, stream channels, riparian corridors and other landscapes as replacement or mitigation for impacts of transportation related construction. Typical activities that result in soil disturbance include clearing and grubbing existing vegetation, construction of staging areas, excavation and

embankment work, construction of drainage facilities, grading of slopes, and preparation for final seeding, planting and soil stabilization. Other related construction activities generate wastewater directly, such as wet sawing of concrete or directional boring. The type of construction activities greatly affects the amount and type of BMP's which may be required.

5.4 Erosion Prevention vs. Sediment Control

It is more effective to provide erosion prevention measures rather than sediment control. Although every ESCP will have elements of both, it is more cost effective and practical to emphasize erosion prevention. Erosion prevention measures are designed to prevent exposed soil particles from becoming dislodged by rain or wind. Erosion control measures are described in Chapter 3 -.

Sediment control involves the capture and retention of dislodged sediment from runoff. Sediment control measures are described in chapter 3. The benefit of erosion prevention is that it seeks to prevent the problem before it starts. It is also impractical to clarify large amounts of sediment-laden water. One half inch of rain on one acre is 67 cubic yards, so the volumes become unwieldy quickly. On projects where the predominant soil particle size is very small (fine silts and clays), the amount of time required to allow for settling of solids can reach days or even weeks. It is also generally true that erosion control measures are more reliable, whereas sediment control measures require frequent maintenance that becomes expensive. Because successful erosion control requires minimizing disturbed areas, the ESCP should emphasize scheduling and phasing. Project scheduling and phasing is often driven by factors other than erosion control. Because of this, contingency planning is essential.

After the Pre-Construction meeting, the ESCP is the responsibility of the Contractor who knows best the scheduling and the construction means and methods. During the course of construction, the ESCP is expected to be a dynamic plan that is adapted to address changes in the project.

5.5 Assessing the Project Site

The erosion and sediment control plan should seek to protect the soil surface from erosion, control the volume and velocity of runoff, and capture all sediment on-site during each phase of the construction project.

When assessing erosion control needs for the project, the designer should note any of the following conditions:

5.5.1 Regulatory Requirements

1. Conditions and requirements of the NPDES 1200-CA permit, including potential penalties for violations or non-compliance.
2. Conditions are requirements associated with the Army Corps of Engineers 404 permit and associated 401 certification.
3. Particular requirements from local permitting agency, municipality or county.

4. Special requirements by the Oregon Department of Fish and Wildlife, Department of Environmental Quality or other agencies.
5. Recommendations and considerations, including endangered species, mentioned in the Federal Aid Highway Programmatic (FAHP), E.A., EIS, Environmental Technical Report and any other project related documents.

5.5.2 Existing Conditions

1. Type and condition of existing vegetation.
2. Soil types expected.
3. Runoff flowing onto the construction site.
4. Swales or streams which run through the site and their watershed areas.
5. Runoff which concentrates in drainage swales or ditches.
6. Streams that could rise during high water flow.
7. Storm drain system with inlets, which might receive sediment-laden water.
8. Outlets at culverts and other storm water conveyances.
9. Permanent landscaping.

5.5.3 Construction Conditions

1. Contract requirements as defined in erosion and sediment control plans, 00280 specifications and 00280 special provisions.
2. Construction traffic crossing a drainage swale or stream. (Do not allow driving through water. Temporary culverts and crossings are simple BMPs)
3. Runoff flowing onto the construction site.
4. Runoff that will flow onto disturbed areas having slopes 1:4 or steeper.
5. Cut or fill slopes 1:3 or steeper and higher than 6 ft.
6. Runoff leaving the disturbed areas as sheet flow.
7. Runoff leaving disturbed areas as concentrated flow.
8. Runoff from paved or other impervious areas, especially prior to completion of storm drainage system.
9. Exposed soils within 100 ft. of a waterway or wetland.
10. Disturbed areas of more than 5 acres that drain to a common location.
11. Disturbed areas of less than 5 acres that drain to a common location.
12. Staging and stockpile areas
13. Identifying and controlling pollution or contamination found on site
14. Temporary alignments for traffic bypass of work area
15. On-site haul routes
16. Storm drain system with inlets that might receive sediment-laden water.
17. Outlets at culverts and other storm water conveyances.
18. Permanent landscaping

5.6 Five Basic Rules

Attention to the following five basic rules at the planning stage will help develop a successful program:

1. **Timing** – Schedule work to minimize overall impacts.
2. **Stage Work** – Identify and process critical areas first, look at new drainage patterns created through phases of construction. Provide erosion and sediment control fitted to conditions during each phase of construction.
3. **Minimize Disturbances** – Create buffers and reduce mass grading.
4. **Pre-construction Planning** – Identify construction sequences and lay out erosion control measures.
5. **Documentation** – Photograph/video/record existing conditions and throughout construction. Use the monitoring form [734-2361](#). Monitoring of ESCP and documentation of that monitoring is required during construction by both the 1200-CA permit and in the Specifications.

As the ownership of the ESCP moves from design to the contractor, it should be developed according to the following general principles of erosion and sedimentation (as discussed in Chapter 2).

1. Fit grading to the surrounding terrain.
2. Time grading operations to minimize soil disturbance.
3. Emphasize erosion control measures to stabilize disturbed areas.
4. Retain existing vegetation wherever possible.
5. Direct runoff away from disturbed areas.
6. Minimize the length and steepness of slopes.
7. Use energy dissipation devices to reduce runoff velocities.
8. Install permanent storm drainage facilities as soon as possible.
9. Manage clean water to prevent it from coming into contact with exposed soil.

Erosion and Sediment Control is contracted work that the contractor has agreed, in the contract, to provide. That work includes all of the items listed above plus monitoring and ESCP revisions. Unmentioned, but implicit is that contractors think about this work, that they are proactive and anticipate issues and responses rather than being reactive and addressing problems.

5.7 Project Scheduling

Following a specified work schedule that coordinates the timing of land disturbing activities and the installation of control measures is perhaps the most cost-effective way of controlling erosion during construction. The removal of ground cover leaves a site vulnerable to accelerated erosion. Construction procedures that limit land clearing, provide the timely installation of erosion control and sedimentation controls, and restore protective cover quickly can significantly reduce the erosion potential of a site.

Construction projects should be sequenced to reduce the amount and duration of soil exposure to erosion by wind, rain, runoff, and vehicle tracking. The Contractor's ESCP uses the construction schedule to list all major land disturbing activities that will be used to identify the erosion and sedimentation control measures needed for a project. This type of schedule guides the contractor on work sequencing so that serious erosion and sedimentation problems can be avoided.

The Contractor's ESCP must indicate in each phase of the scheduled work, including how the proposed erosion/sediment control measures will divert flows, store flows, limit runoff from exposed areas, stabilize exposed soil and filter sediment for each phase of work. The following activities should be included in the schedule, if applicable:

- Clearing and grubbing for perimeter controls.
- Installation of perimeter controls.
- Construction phasing.
- Clearing and grubbing, grading and trenching for activities other than perimeter control.
- Grading (including off-site activities) related to the project.
- Final grading, landscaping, and stabilization.
- Work on or at bridges and other watercourse structures.
- Utility installation and removal.
- Work required in any wetland.
- Monitoring of rainfall.
- Inspection of controls.
- Installation and maintenance of permanent controls.
- Installation, maintenance, and removal of temporary controls.
- Disposal of waste materials generated on-site.

Note that the construction activities listed above do not usually occur in a specified linear sequence, and schedules will vary due to weather and other unpredictable factors.

Schedules for temporary and permanent erosion control work and the multiple components of the contracted work, must be submitted for review by the Agency. Plans for erosion control on haul roads and borrow pits and plans for disposal of waste materials should also be submitted. It is uncommon that the ESCP in the project's plans will have the details of the Contractor's schedule, personnel, or means and methods. The contractor may submit the ESCP from the project plans if it is correct for the proposed stage of construction. It is usually necessary for the Contractor to prepare a modified version of the Agency's ESCP, proposing using their insight regarding construction methods and site conditions at the time of construction to create a more accurate ESCP. Each modified ESCP must be submitted to DEQ to keep their files current.

5.8 Site Characteristics

Projects should be designed to integrate existing land contours. This practice diminishes the area of exposed soil. The existing site terrain and vegetation should be inventoried and evaluated. Decisions must be made on the steepness of cut and fill slopes, how they will be protected from runoff, how they will be stabilized, and how they will be maintained. Whenever possible, slopes should be inclined 1V:2H or flatter to reduce erosion potential and increase slope stability. Steeper slopes are unstable and may increase maintenance issues.

5.9 Grading Plan

The grading plan should be utilized to establish drainage areas, drainage patterns, and runoff velocities. The plan should identify disturbed areas, cuts, fills, and finished project elevations. The proposed grades define the proposed flow of water and the locations where erosion risks will be introduced. The Contractor's ESCP must provide means for controlling erosion on the graded site and preventing sedimentation downstream for all phases of construction. These BMPs may be temporary or permanent; depending upon the need after construction is completed

Chapter 6 - EROSION AND SEDIMENT CONTROL PLAN (ESCP) DESIGN

6.1 Background

The purpose of erosion and sediment control planning is to clearly establish which control measures are appropriate to prevent erosion and control sedimentation during construction. The Erosion and Sediment Control Plan (ESCP) provided in the Project Plans (Agency ESCP) should serve as a guide for the location and installation of measures to control erosion and prevent sediment from leaving the site during construction. An example an Agency ESCP with explanatory notes is included in Appendix C.

The planning and design for the Agency ESCP is included in Contract Plans. Once the contract is awarded, the ESCP is “owned” by the contractor who dictates the details of the project construction. Even though the contractor is the lead on erosion and sediment control during construction, ODOT is the permittee and ultimately responsible for effective functioning of the ESCP and compliance with regulatory requirements.

The Agency ESCP also identifies measures to control volume, velocity and peak flow rates of storm water runoff so to keep the quantity and velocity of runoff leaving the site similar to conditions that existed prior to construction. Permanent storm water management facilities such as curbs, inlets, gutters, etc. may be incorporated as elements of the Contractor’s ESCP for use during construction. It is worth noting that plans must also address the stormwater runoff before these facilities are built.

In order to prevent pollution related to its construction, ODOT requires a Pollution Control Plan (PCP). On projects where pollutants or contaminated materials are known to be present, where they will be used during construction or that the project could potentially expose pollutants or contaminated material an Environmental Management Plan (EMP) must be provided as part of the project’s ESCP. Details of the EMP’s requirements are provided in the [1200-CA’s Attachment A](#). For projects with minimal soil disturbance ODOT may specify that the contractor develop both the PCP and the ESCP. Otherwise, ODOT develops the ESCP and the contractor modifies it to fit the construction scenario. The contractor develops the PCP.

An approved ESCP is the primary document addressing erosion and sedimentation. The ESCP is reviewed and approved by ODOT prior to beginning construction. The ESCP will also be submitted to DEQ prior to beginning of construction with project greater than 5 acres being provided to the public for a public review period. ODOT has 1200-CA permits for each Region and local jurisdiction permits are required if regulations for a local agency are more stringent than that described in the 1200-CA. The Agency ESCP consists of plans, details, and Specifications 00280, 00290, and 01030 in the contract documents. The Contractor’s ESCP must be available on the construction site for review.

Typically, internal review of the Agency ESCP occur at the preliminary, advanced and final stages of the project along with other sections of the contract plans. The Agency ESCP should be developed and included in the distribution of the preliminary plans. A more complete Agency ESCP, including details, specifications bid list and cost estimate, should be developed for inclusion in the advanced plans. Once the plan is developed and before the plan goes to final approval, the designer should request review of the plan, special provisions and details by an erosion control designer in the Geo-Environmental Section.

6.1.1 Designer Responsibilities

A designer puts the Agency ESCP together in the office based upon information provided from the surveyors, the roadway plans and field site visits. The ESCP for ODOT projects must be stamped and signed by a professional with one of the following credentials:

- Oregon Registered Professional Engineer.
- Oregon Registered Landscape Architect.
- Oregon Certified Engineering Geologist.

An ESCP must include a variety of BMP's on the plan order to provide a variety of tools in sufficient quantity to address erosion, control runoff, sedimentation and protect the project site through all phases of construction. The ESCP should include also emergency BMP materials that can be quickly deployed in the event of severe weather events. The Agency ESCP provides enforceable contract requirements to hold contractors accountable.

The contractor bids on the work outlined in the Agency plans, not more and not less. After the Agency ESCP is created in the office, the reality of construction and Mother Nature will change site conditions. Changes to the Contractor's ESCP are inevitable, and mandatory. It is important that the designer anticipate wet season work, emergency materials, schedule delays and provide sufficient erosion and sediment control measures that the contractor's scope of work is adequately defined.

Once a project is in construction, it is the responsibility of the project inspector to see that the contractor keeps the project in compliance with the NPDES Permit and the contract. If the plan does not provide adequate "enforcement pieces" (BMPs, and requirements) in the Agency Plans, Specs and Estimate, the inspector might find that compliance can be difficult to enforce. The designer must anticipate erosion and sedimentation issues that could occur during construction and provide BMPs that provide final stabilization. When potential issues are addressed with a variety of BMPs and with sufficient quantity, expensive change orders can be minimized. Change orders are common, but are costly, burdensome and best avoided. Provide a good plan and keep open lines of communication with the construction team.

6.2 Plan Preparation

Chapter 5 discusses the ODOT ESCP planning process. Chapter 6 will be of interest primarily to designers; however, much of the information included is useful to persons involved in ESCP implementation.

6.2.1 Assessing the Project Site

To develop the ESCP, a designer must, (1) Understand the project site including drainage patterns, soils, slopes, nearby waters and other sensitive areas, (2) the project including nature of and phases of construction, (3) identify potential erosion and sediment problems, (4) develop design objectives, (5) formulate and evaluate alternatives, (6) select best erosion control measures to combat potential concerns and (7) develop a plan.

The following site and project information are required to be evaluated for project design:

- Surface soil types and erodability.
- Extent and location of soil disturbance (total area).
- What kind of runoff and how much is coming onto the construction site? Clean rainwater from a stabilized site, bare ground runoff, sheet flows, channel flows, etc.?
- Where is the total runoff volume going to exit and how?
- In a major rain event, what are the worst-case scenarios upstream and downstream?
- What is the overall construction environment? Urban, rural, open fields, industrial, pristine forestland?
- When will construction take place in relation to wet season? What is the construction schedule? Will construction be phased?

The designer should note the following conditions that exist:

- Requirements of permitting and local agencies. Requirements of the 1200-CA permit are plainly written in the document.
- Special requirements by Oregon Department of Fish and Wildlife, Department of Forestry, NOAA-Fisheries, or the Department of Environmental Quality. This information is gathered at project team meetings or with the assistance of the Region Environmental Coordinator (REC) or the ODOT Environmental Section.
- Type and condition of existing vegetation. Note whether the existing vegetation has root mass that is capable of holding the soil in place and a leaf canopy that can break the velocity of overland flow. If sediment is suspended in the runoff, can it settle out before it reaches surface water? Does the topography of the site trap sediment that has been entrained? These questions will help the designer to determine whether clearing limits are required.

The designer should insist on detailed contour maps of existing and proposed conditions be provided to fully understand the nature of the topography, drainage patterns, existing vegetation and built environment. Agency developed Drainage and Utility Plans, Roadway Plans and staging plans all provide vital information during design. Cross sections and profiles can be instrumental in helping designers understand how grading varies along a projects length.

6.2.1.1 Soil Types

Knowing the type of soil found on the project site will help the designer decide upon the degree of erosion protection required. This will ensure that the ESCP is adequate to control soil movement without being overly conservative. Soil information is found in the Natural Resource Conservation Service Soil Survey, a mapped inventory by county with physical properties and characteristics described for each soil type.

One can roughly determine soil type by feeling the soil. Visit the project site and pick up a handful of soil. Rub it between your fingers. Does it feel gritty like sand or is it smooth like powder? Gritty soils may indicate a high content of sand. Clays and silts feel powdery when dry. Clay is sticky when wet. Soils that contain mostly sand will drain freely and resist erosion, but once sandy soils become saturated they are very erodible. Silts and clays absorb water slowly before becoming saturated and cause runoff of rainwater on the soil’s surface. In addition, clays and silts have smaller particles that are easily detached and carried in runoff and are slow and difficult to settle out of suspension.

The soils found on a construction site are often highly disturbed and do not resemble the native soil. Consider the depth of cut on the project and what soils are there. Consider the fill material. Will these soils be erodible? Will they sustain vegetation or be covered with rock? Will they become highly compacted? Soil particle properties, such as size, shape, and density have a direct effect on soil detachment, dispersion, transport, and eventual deposition. For example, a fine textured soil having large amounts of silt is quite susceptible to erosion from rain splash and runoff. The smaller, lighter particles (fine sand and clays) are transported by water more easily than the coarser particles: as soil particle size increases the soil’s erodibility decreases.

Table 6-1 USDA Particle size classes

USDA Particle Size Classes

<u>Particle name</u>	<u>Size, inches</u>	
Gravel	Greater than 0.0787	<i>Larger = Less Erodible</i>
Sand	0.0787-0.00394	
Very fine sand	0.00394-0.00197	
Silt	0.00197-0.0000787	
Clay	Less than 0.0000787	<i>Smaller = More Erodible</i>

6.2.1.2 Topography

From the site visit, determine the drainage patterns from the topography. Does runoff flow from offsite through the construction site? If so, measures should be taken to re-route this clean water around (under) areas that will have ground disturbance.

Will areas of soil disturbance occur on long slopes that are greater than a 2% grade? If so, the lengths of these uninterrupted flows should be broken up so that the rainfall runoff will only flow short distances thereby decreasing flow velocity and the erosive force. In flat areas, runoff is slow and soil particles are not moved far from the point of raindrop impact. If the slopes are steep and short,

surface cover may be needed to decrease runoff and promote rainfall infiltration into the soil. On steep slopes, soil movement increases dramatically. For example, on a 100 ft. long slope, doubling the gradient from 1:3 to 1:1.5 triples the soil loss. Constructing long slopes and especially, long, steep slopes, should be avoided, however on road project that is not always possible. Steep slopes that already exist should not be disturbed.

6.2.1.3 ESCP – Determine Applicable Design Elements

Once the project site has been assessed, the catch points for cuts and fills, drainage areas and drainage patterns, sensitive areas, size and location of drainage structures, and of disturbance should be located on the base map. Approximate final slope (grades) and any known problems such as highly erodible soils or unstable slopes should also be noted.

The following eight elements should be evaluated for every project. Erosion control measures should be chosen based on the elements which apply to the project and on the Best Management Practices design criteria in Chapter 4, Erosion and Sediment Control Measures and Best Management Practices.

6.2.1.4 Clearing Limit

Limiting site disturbance is an effective method for reducing erosion. Clearing limits prevent disturbance of areas not designated for clearing or grading, protect the natural environment, provide a buffer between disturbed areas and sensitive areas and reduces the need for other erosion control measures. Buffers, 50' wide of undisturbed vegetation (or BMPs providing equivalent protection) are required between project work and waterways. Clearing limits shown on the plan should be clearly marked in the field. This is not necessary outside of the project right of way.

Since clearing limits should be marked before ground disturbance occurs, the designer should show the regulated areas and sensitive areas as “no work” areas on the ESCP, even when the “no work” areas are shown elsewhere in the plans. Trees to be preserved should be delineated and no material storage or vehicles should be allowed on tree root zones. Regulated areas, sensitive areas and their buffers may require more substantial protection such as plastic or metal safety fences or stake and wire fences. Orange type sediment fence, when used correctly as a sediment barrier can double as a boundary delineator, marking sensitive areas and their buffers. However, sediment fences should only be used for this purpose if it is also needed for sediment control.

6.2.1.5 Sensitive Area Restrictions

Any project, regardless of size, that disturbs areas near or within a stream or associated buffer, a wetland or its associated buffer, or within 100 ft. of a lake has the potential to seriously damage water resources. Projects along or near waterways may have special requirements that should be incorporated into the Agency ESCP. Contact ODOT Environmental Section for specific requirements.

When dealing with sensitive areas, the following recommendations should be incorporated into the plan where appropriate:

- Before the rainy season, a sediment barrier, or redundant barriers should be constructed between the disturbed areas and the surface water in order to isolate the construction area from the water resource.
- Additional perimeter protection should be installed to prevent sediment entering the surface waters. This might include redundant sediment barriers; sediment fences in combination with sediment barriers, a berm, or application of a thick layer of mulch upslope of a sediment fence.
- Turbid runoff generated by dewatering operations should be directed through a sediment trap, a filter bag or the water released uniformly over a well-vegetated, relatively flat area. A well-vegetated area with dense grass or similar vegetation is a filter for the runoff to pass through. Since pumps are used for dewatering, it may be possible to pump the sediment-laden water away from the surface water so that vegetation can be more effectively utilized for filtration. Active treatment using Baker Tanks is an effective method of treating sediment laden discharge.

6.2.1.6 Surface Water Control (Runoff Control)

Runoff Control collects and conveys surface water to minimize erosion and may:

- Intercept runoff on and above disturbed slopes.
- Divert offsite runoff around project.
- Convey the runoff to a sediment trap, basin or stabilized outlet.
- Release the runoff downslope of any disturbed areas.

Runoff control measures include dikes, swales, ditches, pipe slope drains and level spreaders. Interceptor dikes/swales intercept runoff and take it away from disturbed ground. Ditches and pipe slope drains convey runoff through a site. Riprap or level spreaders dissipate the velocity of runoff and release it in a non-erosive manner. Vegetation-lined channels are often preferable to pipe slope drains whenever the channel gradient does not exceed 5%. Vegetation must be adequately established prior to runoff being diverted into it. Channel liner matting is a proven BMP to stabilize channels and check dams perform well to check flow velocity and remove sediment from turbid runoff. The channel must be designed with an understanding of the capabilities of maintenance and be accessible for maintenance.

The initial grading of an area should be conducted in coordination with stormwater runoff controls. Grading should direct flows to the runoff control BMPs. If the soils and topography are such that no offsite discharge of surface water is anticipated based on the 10-year design storm, surface water controls may not be needed. When using vegetation-lined channels, they should be established early in the project. Irrigation may be required to establish a thick, dense stand of vegetation. Grass may require mowing and removal of the dead plant material to maintain hydraulic function. If vegetation cannot be adequately established, the channel should be protected with matting or rock.

Of especial concern is the runoff control for newly constructed water quality swales. These are required features that usually rely on vegetation for stormwater treatment and the permanent stabilization. These swales are built with lightweight and very erodible soils and vegetation will not be established immediately upon completion of the feature. It is unfortunate but common that

stormwater will be directed through the features prior to establishment of vegetation. Runoff control for water quality (biofiltration) swales should include an appropriate channel liner matting to cover the special soil and removable check dams that will reduce flow velocity during plant establishment.

6.2.1.7 Perimeter Protection

Perimeter protection measures are so named because they are installed at the perimeter of disturbed areas. Perimeter control must be installed prior to any ground disturbing activity and installed down gradient from ground disturbing activity. These measures both reduce runoff velocity and retain sediment while allowing water to pass. Perimeter control could also collect runoff and direct it to a sediment trap or basin for treatment. Perimeter protection can be used as the primary means of sediment removal when the catchment area is very small. It may be a secondary means of sediment removal, for instance, following a sediment trap or basin. Perimeter protection measures include sediment fence and sediment barriers such as fiber rolls, compost socks, compost berms or wood chip berms. Redundant perimeter sediment barriers are sometimes needed to adequately remove sediment. Perimeter protection is a common BMP used on linear projects such as roadway work. Perimeter protection should be used in combination with other measures.

Design and construction of perimeter control must account for concentrated runoff for the work area. Conveyance of runoff from a construction site can more safely be achieved by:

- Utilizing and supplementing existing stable ditches.
- Installing storm drains with stable outlets.
- Controlling runoff velocity
- Designing and constructing stable open channels.

The plan should indicate locations for these design facilities. Perimeter protection measures should be installed prior to clearing and grubbing. Outlets for channels, diversions, slope drains, or other structures should be completed and stabilized before water is diverted to them. Impacts to existing facilities, if they are to be used for erosion control during construction, should be evaluated.

6.2.1.8 Revised Universal Soil Loss Equation (RUSLE)

In order to properly design retention and conveyance structures, a designer must be able to calculate the quantities of water and sediment that will be managed by the structure. Plans for stormwater detention facilities and sediment traps must be designed for, not less than a 2 year, 24 hour storm or with the storage volume of not less than 3600 cubic feet (smaller facilities may be acceptable if used in combination with other effective BMPs). Stormwater detention facility plans must be stamped and signed by either a licensed and qualified landscape architect or professional engineer. For smaller structures such as sediment traps, lined swales or check dams, design details can be developed using simple guidelines based on general assumptions about soil type and tributary area. This is generally acceptable because the failure of one of these BMP's would not generally be a catastrophic event. Moreover, maintenance of these BMP's is relatively simple and if sediment loads are higher than expected, they can be easily modified and maintained more frequently without loss of effectiveness. The design and construction of a sediment basin or large conveyance is more

rigorous, however, because failure of these types of structures could seriously endanger natural resources or human life. In addition, they cannot be easily maintained when in use during the rainy season. For this reason, the designer needs to be able to calculate the quantity of sediment that will be transported or retained in a structure. The design method for calculating soil loss from disturbed land presented in this manual is the Revised Universal Soil Loss Equation (RUSLE). RUSLE estimates soil loss from a slope caused by raindrop impact and overland flow (collectively referred to as “inter-rill” erosion), plus rill erosion. It does not estimate gully or stream-channel erosion. RUSLE is a tool to estimate the rate of soil loss based on site-specific environmental conditions and a guide for the selection and design of sediment and erosion-control systems for the site. RUSLE does not determine when soil loss is excessive at a site, or when erosion-control systems have failed. The RUSLE user makes such decisions based upon numerous criteria, of which soil-loss and sediment-yield estimates are one important component.

Portions of the following paragraphs describing RUSLE were excerpted from Chapter 1 of the Guidelines for the use of RUSLE – Version 1.06, with permission of Publishing Editor Joe Galetovic of the Office of Surface Mining in Denver, Colorado. For a copy of the complete guidelines and RUSLE software, please contact:

The Office of Technology Transfer Western
Regional Coordinating Center Office of Surface
Mining
1999 Broadway, Suite 3320
Denver, CO 80202-5733

The Revised Universal Soil Loss Equation (RUSLE, Renard et al., 1997) is a technology for estimating soil loss from most undisturbed lands experiencing overland flow, from lands undergoing disturbance, and from newly or established reclaimed lands. RUSLE also may be used as a part of the procedures to prepare permit applications and to assess reclamation success in support of bond release.

6.2.1.8.1 Erosion Terminology

Several terms are used in association with the removal of soil from the land surface. Although there is not complete agreement in the connotations attributed to these terms, the following definitions are employed in this report.

- Erosion includes a group of processes by which earth materials are detached, entrained and transported across a given surface.
- Soil loss is that material actually removed from the particular hillslope or hillslope segment. The soil loss may be less than erosion due to onsite deposition in micro-topographic depressions on the hillslope.

- Sediment yield from a surface is the sum of the soil losses minus deposition in macro-topographic depressions, at the toe of the hillslope, along field boundaries, or in terraces and channels sculpted into the hillslope.

RUSLE estimates soil loss from a hillslope caused by raindrop impact and overland flow (collectively referred to as “interrill” erosion), plus rill erosion. It does not estimate gully or stream-channel erosion.

6.2.1.8.2 The RUSLE Model

RUSLE is a set of mathematical equations that estimate average annual soil loss and sediment yield resulting from interrill and rill erosion. It is derived from the theory of erosion processes, more than 10,000 plot-years of data from natural rainfall plots, and numerous rainfall-simulation plots. RUSLE is an exceptionally well-validated and documented equation. A strength of RUSLE is that it was developed by a group of nationally recognized scientists and soil conservationists who had considerable experience with erosional processes (Soil and Water Conservation Society, 1993).

RUSLE retains the structure of its predecessor, the Universal Soil Loss Equation (USLE, Wischmeier and Smith, 1978), namely:

$$A = R K L S C P \quad (1)$$

Where: A = Average annual soil loss in tons per acre per year
R = Rainfall/runoff erosivity

K = Soil erodibility

LS = Hillslope length and steepness

C = Cover-management

P = Support practice

In overview, the R, K and LS values are integers that when factored in the equation increase soil loss values and the C and P values are decimal fractions that when factored in the equation decrease soil loss values.

The R factor is an expression of the erosivity of rainfall and runoff at a particular location. The value of “R” increases as the amount and intensity of rainfall increase. For user convenience, these data are contained in the CITY database file provided within the computer program. The basic program includes the files for numerous cities throughout the United States, but many more site-specific files are available within each state from the offices of the United States Department of Agriculture (USDA), Natural Resources Conservation Service (NRCS); formerly the Soil Conservation Service, (SCS).

The K factor is an expression of the inherent erodibility of the soil or surface material at a particular site under standard experimental conditions. The value of “K” is a function of the particle-size distribution, organic-matter content, structure, and permeability of the soil or surface

material. For undisturbed soils, the nomograph equations embedded within the RUSLE program are used to compute appropriate erodibility values.

The LS factor is an expression of the effect of topography, specifically hillslope length and steepness, on rates of soil loss at a particular site. The value of "LS" increases as hillslope length and steepness increase, under the assumption that runoff accumulates and accelerates in the downslope direction. This assumption is usually valid for lands experiencing overland flow but may not be valid for forest and other densely vegetated areas.

The C factor is an expression of the effects of surface covers and roughness on rates of soil loss at a particular site. The value of "C" decreases as surface cover increases, thus protecting the soil from rain splash and runoff. For user convenience in determining the "C" factor, a VEGETATION database file is contained within the computer program that characterizes numerous plant types. Likewise, the files include other types of surface treatments used as temporary covers for erosion control.

RUSLE also contains an OPERATIONS database file that characterizes the effects of various soil-disturbing activities on soil-loss rates. These operations alter the roughness, infiltration, distribution of biomass, and runoff properties of the surface. The operations usually are common tillage activities that may be used in the development of a seedbed at reclaimed sites. The files include activities specific to erosion control and disturbed-land reclamation. The effectiveness of cover-management sub-factors varies with local conditions.

Therefore, the user is strongly encouraged to calculate C values through the RUSLE equations rather than selecting values from generalized tables.

The P factor is an expression of the effects of supporting conservation practices, such as contouring, buffer strips of close-growing vegetation, and terracing, on soil loss at a particular site. The value of "P" decreases with the installation of these practices because they reduce runoff volume and velocity and encourage the deposition of sediment on the hillslope surface. The effectiveness of certain erosion-control practices varies substantially due to local conditions. For example, contouring is far more effective in low-rainfall areas than in high-rainfall areas.

Therefore, the user is strongly encouraged to calculate P values through the RUSLE equations rather than selecting values from generalized tables.

Care must be exercised to insure that all data inputs are accurate because they may affect several components of soil-loss estimation. It is often prudent to consult with qualified earth and environmental scientists to affirm the accuracy of the data inputs. Further, the soil-loss estimates produced by RUSLE rest upon the assumption that factor inputs accurately reflect field conditions. Factor adjustments are required whenever actual conditions depart from specification.

The recommendations provided herein for the use of RUSLE on mining, construction, and reclaimed land applications represent the best judgment of the Working Group. It is the user's responsibility to determine whether or not RUSLE is applicable to a particular field situation.

These guidelines provide direction for maximizing the accuracy of RUSLE soil-loss estimates on construction sites, and reclaimed lands.

RUSLE is a tool to estimate the rate of soil loss based on site-specific environmental conditions and a guide for the selection and design of sediment and erosion-control systems for the site.

RUSLE does not determine when soil loss is excessive at a site, or when erosion control systems have failed. According to 1200-CA permit which regulates ODOT construction, the determining factor for the success or failure of erosion control systems is if sediment or sediment-laden water has left the project site.

6.2.1.9 Sediment Retention

Sediment retention measures remove sediment from runoff by holding a volume of water for a length of time, allowing soil particles to settle out of liquid suspension. Sediment retention is used as a last line of defense when included in an ESCP. Other design elements must also be included in the plan to assure sediment from erosion is under control.

When sediment retention is used by itself, the potential for catastrophic failures is high. Sediment traps are a common facility used for sediment retention. When a sediment trap is required, it should be shown on the ESCP with the dimensions of each trap described on the sediment trap detail or plan sheets.

6.2.1.9.1 Sediment Trap Sizing

Sediment traps must be sized to handle the area contributing sediment-laden runoff. The following design criteria are based on a variation of the Rational Formula, allowing a relatively simple set of calculations to be used to size the traps, while accounting for rainfall patterns that occur in different hydrologic zones across the state. Facilities designed to collect contributing areas up to 5 acres can use these design criteria. Facilities designed to collect contributing areas larger than 5 acres must use more thorough design criteria and would then be considered a Sediment Basin. Refer to the Volume 1 of the ODOT Hydraulics Manual for more detailed designed guidance.

STEP 1: Calculate the Storage Volume (V), using a variation of the Rational Formula.

Determine the volume of rainfall generated by the 10-year, 6-hour rainfall event over the contributing area to the trap.

$$V = (C) \times (I) \times (A) \times (\text{Duration})$$

Constants (assumed)

C = 0.5 = runoff Coefficient assumed to represent smooth graded area with no vegetation.

Duration = T_c = Time of Concentration = 6 hrs. = **21,600 sec**

STEP 1-A: Determine area contributing sediment laden runoff to the sediment trap. Areas with existing vegetation or paved surfaces need not be included when determining this area.

A = Contributing Area (acre)

STEP 1-B: Determine hydrologic zone within which the project site is located. Refer to I-D- R Curve Zone Map in Appendix D.

Zone = Hydrologic Zone

STEP 1-C: Determine rainfall intensity generated by the 10-year, 6-hour rainfall event. Use the following table to select the appropriate intensity.

I_{10} = Intensity (in/hr)

Zone	1	2	3	4	5	6	7	8	9	10	11	12	13
I_{10} (in/hr)	0.4	0.4	0.3	0.3	0.3	0.3	0.2	0.2	0.2	0.1	0.1	0.1	0.1
	5	2	7	7	7		7	8	5	9	8	9	5

STEP 1-D: Determine the volume of required storage.

By using the formula described in STEP 1 and applying the assumed constants, the formula can be simplified to:

$$V (\text{ft.}^3) = I A (10,800)$$

Divide the storage volume evenly between dry and wet storage. The wet storage normally occupies the bottom two-thirds of the trap depth. **Example**

Required: Determine required volume for a temporary sediment trap. Given: A = 1.2 acre;

Site Location = Alesia, Oregon

Solution: Alesia is located in Zone 4; I_{10} for 6-hr storm in Zone 4 = 0.37 in/hr.

$$V = (0.37 \text{ in/hr}) \times (1.2 \text{ acre}) \times (10,800) = \underline{4,795 \text{ ft.}^3}$$

STEP 2: Calculate the dimensions of the sediment trap by satisfying the volume requirements.

The trap dimensions must be assumed and then the volume of the trap based on the initial assumptions can be calculated using the following:

$$V = [LWD] + [(L+W)ZD^2] + [4/3Z^2D^3]$$

Where:

- V = Storage Volume
- W = Width of Trap on Bottom
- L = Length of Trap on Bottom
- D = Depth of Trap
- Z = Side slope (1:Z; vertical to horizontal)

Example

Required: Determine volume of proposed temporary sediment trap. Given:

$$W = 10 \text{ ft.}, L = 30 \text{ ft.}, D = 4.5 \text{ ft.}, Z = 3$$

Solution: $V = [30 \times 10 \times 4.5] + [(30+10) \times 3 \times 4.5^2] + [(4/3) \times 3^2 \times 4.5^3] = \underline{4,874 \text{ ft.}^3}$

STEP 3: Outlet Structure Design: The outlet structure for a temporary sediment trap should be sized to handle expected flows. For most sediment traps a rock weir (spillway) will be sufficient. For larger flows or areas with heavy sediment loading a perforated riser pipe may need to be used as outlet to the trap. Outlet structure must take and discharge water from surface of sediment trap water.

ROCK WIER The crest of the weir should be 1 ft. below the top of the embankment. The weir should be constructed of two layers of different size rock. The top 12 in. must be 3-6 in. riprap. The bottom layer should be of a smaller size. If large flows are expected, the size of the rock should be designed for stability in accordance with Volume 1 of the ODOT Hydraulics Manual.

Rock Weir Sizing: The weir length (X) can be estimated using the broad crested weir equation and assuming a 1 in. flow depth over the weir (H). The amount of flow going over the weir can be estimated using the information developed for sizing the trap. Assume a weir coefficient (C_w) of 0.4.

$$Q = C I_{10} A \quad \text{(Rational Formula)}$$

$$X = \{(3/16) Q/C - [0.8(\text{Tan } \Theta) H^{2.5}]\} / H^{1.5} \quad \text{(Broad Crested Weir Formula)}$$

$$X \text{ (ft.)} = 6 I_{10} A$$

Example

Required: Determine length of rock weir.

Given: A = 1.2 acre; Site Location = Alsea, Oregon

Solution: Alsea is located in Zone 4; I10 for 6-hr storm in Zone 4 = 0.37 in/hr.

$$X = (6) \times (0.37 \text{ in/hr}) \times (1.2 \text{ acre}) = 2.7 \text{ ft. } \underline{\text{use 3 ft. min}}$$

RISER PIPE An alternate to the rock weir outlet is a riser pipe. A typical detail for the riser pipe should show the following:

- Pipe slit perforations, which are .6 in. wide by 6 in. long, or 1 in. diameter holes spaced 6 in. vertically and horizontally from the outside edges above the wet storage elevation.
- The riser pipe should be wrapped with .3 to .6 in. wire hardware cloth and covered with geotextile overlapped, folded and fastened at the seam. The geotextile should extend 6 in. above and below the highest and lowest slits and should be secured top and bottom with straps or connecting bands.
- Anchor the riser using a concrete or steel base. The concrete base should be 20 in. deep with the riser embedded 10 in. The steel base should be .3 in. thick, welded watertight to the riser and covered with 2 ft. of stone or gravel.
- Table 6-3 gives riser pipe diameters for different size drainage areas.
- Floating outlet “skimmers” are manufactured products which float drain sediment traps from surface water where the sediment load of the water is its least. Floating “skimmers” are made in a variety of diameters for different size sediment traps.

Table 6-2 Outlet riser pipe diameters.

Maximum Area	Drainage	Minimum Diameter	Barrel	Minimum Diameter	Riser
1 acre		24 in.		15 in.	
2 acres		15 in.		18 in.	
3 acres		18 in.		21 in.	
4 acres		21 in.		24 in.	
5 acres		21 in.		27 in.	

6.2.1.9.2 Recommended Limits

A list of recommended size limits must be checked prior to completing the trap sizing calculations. These limits include:

Table 6-3 List of recommended outlet riser pipe diameters

Recommended Limits		
Variable	Min	Max
V	890	17,658
D	1.1	1.5
L	3	N/A
W	1	N/A
L/W	2	N/A
Z	2	N/A
X	1	N/A

- V Acceptable volumes using this design criteria are 890 ft.³ to 17,658 ft.³. Sediment traps smaller than 33 yd.³ are equivalent to a check dam. Sediment traps larger than 654 yd.³ are considered a sediment basin and designed using more thorough methods.
- D Sediment traps shallower than 3 ft. will not provide adequate settling depth or wet vs. dry storage volume separation. Sediment traps deeper than 5 ft. are considered a sediment basin and designed using more thorough methods.
- L Any sediment trap shorter than 10 ft. is equivalent to a check dam.
- L/W Calculate the trap length (L) using: $L = 3W$
If site conditions disallow a 1:3 L/W ratio, a 1:2 may be used if the traps are small in size.
- W Any sediment trap narrower than 3 ft. is equivalent to a check dam.
- Z Optimum side slopes are 1:3. Side slopes as steep as 1:2 can be used if site conditions cannot sustain flatter slopes. Slopes may be steeper than 1:2 if ground consists of stable rock.
- X Rock weirs (spillway) narrower than 3 ft. provide less effective flow spreading and may contribute to erosion downstream.

Design Options

Site conditions often dictate sediment trap sizes and locations. When required sediment trap volumes exceed feasible site location conditions the following options can be considered:

- Design smaller sediment traps and place them in series instead of providing one large sediment trap.

- Limiting areas of disturbance (which reduces the area the sediment trap must serve).

Spreadsheet Analysis

A spreadsheet has been developed to assist designing temporary sediment traps. The spreadsheet calculates STEP 1, STEP 2, STEP 3 (rock weir only) and checks the recommended limits. The location of the spreadsheet is discussed in section 6.3.

6.2.2 Cover Measures

Temporary and permanent cover measures protect disturbed areas. Covering exposed soils prevents erosion, thus reducing reliance on less effective sediment removal. Ideally, all disturbed ground not being worked should be covered to prevent wind and water erosion.

Temporary cover protects disturbed areas not at finished grade or areas that will be redisturbed at a later date. Temporary cover methods include mulch, erosion control matting, plastic sheeting, seeding, sodding, and others as discussed in Chapter 3. Mulch and plastic sheeting protect disturbed areas from days to a few months. Plastic sheeting is most applicable to short-term stockpile protection and on certain slopes steeper than 1:1.5. Seeding and sodding can protect uncovered areas for months. Soil stockpiles should always be protected with plastic sheeting, tarpaulins, sediment barriers, diversion dikes, or combinations thereof.

Permanent cover methods include seeding and mulching, erosion control matting with seed, riprap, gravel, mulch with tree and shrub planting and sodding.

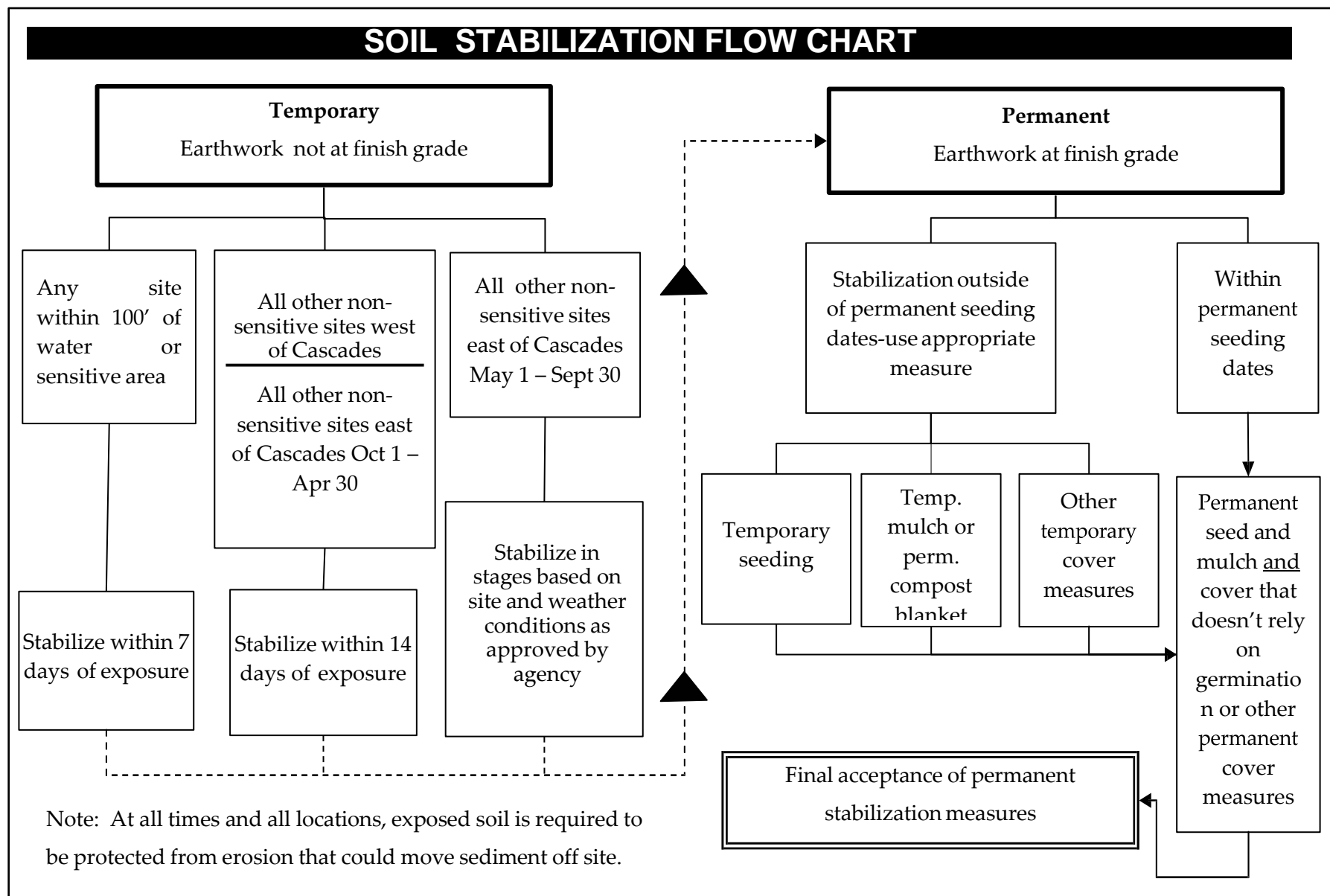


Figure 6-1 Flow diagram of the stabilization requirements found in specifications

Cover measures are described in Section 00280 of the Standard Specifications and seeding dates are described in Section 01030.

6.2.3 Matting

Matting that is appropriate for use on ODOT construction projects and included in ODOTS Qualified Products List (QPL) it must be tested and approved by the Texas Department of Transportation (TXDOT). For roll-type and spray-on erosion control products used to stabilize and revegetate slopes or drainage channels, TXDOT test for two critical performance standards:

1. How well the product protects the surface of the slope or the geometry of the channel from loss of sediment.
2. How well the product promoted the establishment of warm-season perennial vegetation over time.

TXDOT engineers believe that in order for a product to be placed on its Approved Product List (APL), it must meet or exceed the adopted standards for both the sediment loss and the vegetation density factors. A failure within either one prevents a product from being included on the APL.

By analyzing how products actually performed, TXDOT has established both a maximum allowable sediment loss standard and a minimum vegetation density standard for each of four possible slope/soil combinations on an embankment.

To determine the type of matting that will be appropriate for slope protection, the designer must know the soil type and the slope steepness, i.e. 1:2 or 1:3 (V:H). To determine the type of matting appropriate for channel lining, the designer must know the shear stress on the channel bottom. The procedure for determining shear stress is described in Volume 1 of the ODOT Hydraulics Manual.

The latest performance information and the [APL](#) are available on the Web.

The ODOT Specifications list eight-performance grades of slope and channel liner matting that are categorized by letter. Types A, B, C, D and E, the five lightest grades of matting, are required to be fully biodegradable (photodegradable components are not acceptable). Matting types F, G and H are Turf Reinforcement Mattings (TRMs) or channel liner mattings that are robust and usually permanent erosion prevention mattings.

Areas of the ESCP that require erosion control matting should be shown using a patterning that is reflected in the legend.

6.2.4 Traffic Area Stabilization

The stabilization of unpaved roads in the work area, staging areas and construction entrance are required by the 1200-CA permit (Schedule A, 13.2.7). This reduces the amount of sediment that can end up in the drainage system by minimizing the amount of sediment tracked offsite. Construction road and parking area stabilization also reduces safety hazards and nuisance complaints caused by sediment tracking onto public right-of-way. Stabilization of haul routes is

also an excellent form of dust control in the summer months. Traffic area stabilization methods covered in this manual include construction entrance stabilization and construction road/parking area stabilization. Construction entrances are needed to prevent sediment from being tracked offsite or onto paved surfaces and required by the 1200-CA permit. They should be included on the plans, legend, and in the cost estimate. Equipment servicing areas and other areas that require stabilization are included in the Pollution Control Plan and EMP and need not be shown in the ESCP.

6.2.5 Dust Control

Dust control measures minimize the transport of soil by wind, thereby reducing traffic hazards and sediment deposition in water resources. Furthermore, fugitive dust is air pollution which is not only a health concern, but a conspicuous nuisance which often results in complaints. Watering is the most common dust control (palliative) used. Other methods include mulching, seeding, gravel, or spraying exposed areas with an approved dust palliative – see Qualified Products List. Oil, waste, and wastewater are prohibited for use as dust control. Covering haul equipment is required to reduce dust from materials transported offsite. Measures strictly for dust control are included in the Pollution Control Plan however if chemical soil binder or other pay items are specified in plans or special provisions for dust control they must be included in the cost estimate. Dirt that has been tracked onto pavement is a conspicuous source of dust and it is a permit violation and must be removed. A vacuum sweeper is the appropriate tool for dirt removal from pavement. It is never acceptable to allow the flushing of dirt from pavement into waterways or storm sewer systems.

6.2.6 Additional Design Features

In addition to the addressing the issues noted above, the 1200-CA outlines items that are required to be included in an Agency ESCP.

Site Description: A description of the following (when applicable):

- A description of the construction activities, including structures that are planned for demolition.
- The size of the property (in acres and length in miles if a linear construction site).
- A statement that clearly identifies the 303 (d) category 4 and 5 impairments status of each receiving water body (when the discharge enters an impaired watershed unit the listing will only be applied if there is a hydrologic connection between the receiving water and assessment water body causing the impairment);
- Any waterbody to be impacted by the construction activities and reference in 401 water quality certifications, USACE permit, DSL permit, and/or any other applicable agency authorization;
- The total area expected to be disturbed by the construction activities (to the nearest quarter acre or quarter mile if a linear construction site);

- A description of any on-site and off-site construction support activity areas covered by this permit such as staging areas (off site support areas not on Agency lands must have separate NPDES permit and are not under the oversight of the Agency);
- The maximum area expected to be disturbed at any one time, including on-site and Agency controlled offsite construction support activity areas;
- A description and projected schedule for the following:
 - Start dates of construction activities in each portion of the site, site preparation (i.e., excavating, cutting and filling), final grading, and creation of soil vegetation stockpiles requiring stabilization.
 - Temporary or permanent stop dates of construction activities in each portion of the site.
 - Dates of temporary or final stabilization of exposed area for each portion of site.
 - Dates of removal of temporary stormwater controls and construction equipment or vehicles, and the final end date of construction related pollutant generating activities;
- Type of fill material to be used, and of soils prior to disturbance;
- Composition of seed mix and other planting used to establish temporary cover;
- A statement indicating engineered soil will be used, and pH monitoring is required of sedimentation basins;
- Identify all authorized non-stormwater discharges that will or may occur;
- A list and description of all pollutant-generating activities on the site. For each pollutant generating activity include an inventory of pollutants or pollutant constituents (e.g., sediment, fertilizers, pesticides, paints, caulks, sealants, fluorescent light ballasts, contaminated substrates, solvents, fuels, associated with that activity, which could be discharged in stormwater from the construction site. The registrant must take into account where potential spills and leaks could occur that contribute pollutants to stormwater discharges, and may known hazardous or toxic substances, such as PCBs and asbestos, that will be disturbed, removed, or used on site during construction;
 - Description of stormwater controls. For each of the Erosion Prevention and Sediment Control and Treatment Requirements, Pollution Prevention Controls, and Construction Dewatering Requirements, as applicable to the site, registrant must include the following in detail design sheet of the ESCP: 1. A description of the specific controls(s) to be implemented to comply with the requirements of this permit.
 - Any applicable stormwater control design specifications (including references to any manufacturer specifications and/or erosion and sediment control manuals/ordinances relied upon).
 - Routine stormwater control maintenance specifications.
 - Proposed timetable indicating when each sediment and control BMP is to be installed/implemented and duration that it is to remain in place;

- Natural buffer zone and/or equivalent sediment controls between Project work and waterways (see 1200-CA, Appendix B). The registrant must include the following in the narrative site description:
 - The compliance alternative to be implemented.
 - If complying with alternative 1, the width of natural buffer retained.
 - If complying with alternative 2 or 3, the erosion and sediment control(s) the registrant will use to achieve an equivalent sediment reduction, and any information the registrant relied upon to demonstrate the equivalency.
 - If complying with alternative 3, a description of why it is infeasible for the registrant to provide and maintain an undisturbed natural buffer of any size.
 - For "linear construction sites" where it is infeasible to implement compliance alternative 1, 2, or 3, a rationale for this determination, and a description of any buffer width retained and/or supplemental erosion and sediment controls installed.
 - A description of any disturbances that are exempt that occur within 50 feet of a water of the state.
 - A description of the vegetated buffers, sized at 50 feet (horizontally) plus an additional 25 feet (horizontally) per five degrees of slope or DEQ approved control measures of equal effectiveness for any waterbody that is listed as impaired and requiring a TMDL for turbidity or sedimentation on the most recently approved Oregon 303(d) list, or has an established TMDL for turbidity or sedimentation;
- Perimeter controls for a "linear construction site". For areas where perimeter controls are not feasible, include documentation to support this determination and a description of the other practices that will be implemented to prevent discharges of pollutants in stormwater associated with construction activities;
 - Note: Routine maintenance specifications for perimeter controls documented in the ESCP must include requirement that sediment be removed before it has accumulated to one-third of the above-ground height of any perimeter control.
- Sediment track-out controls. Document the specific stabilization techniques and/or controls that will be implemented to remove sediment prior to vehicle exit;
- Sediment basins. The registrant must include the design storm method and calculations, and other design details in the ESCP. In circumstances where it is infeasible to utilize outlet structures that withdraw water from the surface of the sediment basin, include documentation to support this determination, including the specific conditions or time periods when this exception will apply;
- Treatment chemicals. The registrant must include the specific controls and implementation procedures designed to ensure that the use of cationic treatment chemicals will not lead to an exceedance of water quality standards;

- Stabilization measures. The registrant must include the specific vegetative and/or non-vegetative practices that will be used;
- Spill Prevention Procedures. The following must be included:
 - Procedures for expeditiously stopping, containing, and cleaning up spills, leaks, and other releases.
- The ESCP may also reference the existence of oil Spill Prevention Control and Countermeasure (SPCC) plans developed for the construction activity, provided that the registrant keep a copy of the SPCC on site or electronically available.
- Waste management procedures;
- The location of fertilizers applied on site;
- Staff Training. Include documentation that the required personnel are trained in erosion and sediment control and monitoring; and
- Planned business days and hours for the project known at the time.

Site Map: Provide a legible map, or series of maps showing the following features of the site, if applicable:

- Roads and features for DEQ to locate and access the site;
- Boundaries of the property
- Depict the drainage patterns of stormwater and authorized non-stormwater before and after major grading activities;
- Locations where land disturbing activities will occur including:
 - Locations where land disturbing activities will occur (note any phasing), including any demolition activities,
 - For steep slopes clearly label with the words "Steep Slope" and include the percentage grade
 - Locations where sediment, soil, or other construction materials will be stockpiled
 - Clearly label any water of the state crossings with words "water crossing".
 - Designated points where vehicles will exit onto paved roads.
 - Locations of structures and other impervious surfaces upon completion of construction.
 - Locations of on-site and off-site construction support activity areas covered by this permit;
- Locations of springs, wetlands, surface waters, and all waters of Oregon within and one mile downstream of the site's discharge point(description with text is acceptable where location of water exceeds Site Map limits). Also identify if any surface waters are 303(d) Category 4 and 5 listed as impaired (when the discharge enters an impaired watershed unit, the listing will only be applied if there is a hydrologic connection between the receiving water and assessment water body causing the impairment);
- Riparian areas and vegetation including trees and associated rooting zones, and vegetation areas to be preserved;

- Vegetated buffer zones and/or equivalent sediment controls (see Section 13.2.4 and Appendix B) between the site and sensitive areas (e.g., wetlands), and other areas to be preserved, clearly label with the words "Natural Buffer Zone";
- Clearly label the type and extent of pre-construction cover on the site (e.g., vegetative cover, forest, pasture, pavement, structures);
- Temporary and permanent stormwater conveyance systems;
- Location of concrete wash out;
- Location of sanitary facilities;
- Location of nearest official rain gauge, or if used, location of the registrant's onsite rain gauge;
- Onsite water disposal locations (e.g., for dewatering);
- Onsite drain catch basin depicting inlet protections, and a description of the type of catch basins used (e.g., field inlet, curb inlet, grated drain, and combination);
- Septic drain field;
- Existing or proposed drywells or other UICs;
- Drinking water wells on site or adjacent to the site;
- Stormwater planters;
- Detention ponds, storm drain piping, and inflow and outflow details (e.g., bottom elevations and inverts);
- Post-construction stormwater facilities designed and engineered to infiltrate or filter stormwater and associated access restriction control measures;
- Locations of all potential pollutant-generating activities;
- Locations of stormwater controls, including any shared controls utilized to comply with this permit;
- Any other applicable features or controls that are associated with pollution prevention in stormwater discharges;
- Locations where polymers, flocculants, or other treatment chemicals will be used and stored;
- Locations of engineered soils;
- Locations of engineered sediment basins;
- Receiving water(s). Stormwater and authorized non-stormwater discharge point locations, including:
 - Locations where stormwater and/or authorized non-stormwater will be discharged to storm drain inlets; and
 - Locations where stormwater or authorized non-stormwater will be discharged directly to surface waters of the state;
- Detention ponds, storm drain piping, and inflow and outflow details (e.g., bottom elevations and inverts);
- Perimeter controls for a "linear construction site";
- Sediment track-out controls; and

- Stabilization measures. The registrant must include the specific vegetative and/or non-vegetative practices that will be used.

Once the applicable design elements are determined, plan sheets can be developed using the base map. The plan sheets should include enough information at a scale large enough to clearly communicate the ESCP to contractors, inspectors and permitting jurisdictions.

The erosion and sediment control products industry is constantly providing new products and specialized products for unique applications. The industry is developing filtering sediment barriers, new types of inlet protections for trench drains and other unique inlets. Specialized fully biodegradable products are available to provide temporary strengthening for stream channels while vegetative stabilization gets established. Keep apprised of industry advances their use can reduce risk and save the Agency time and money.

6.3 Develop Base Map

The base map for erosion and sediment control plans can easily be developed from the roadway construction base map. Erosion and sediment control plans should be plotted at the same scale as that of the rest of the construction plans. Topographic features for both existing and proposed conditions are important because erosion and sediment control plans must address the transition between those conditions. Contours and sensitive areas are important because the length of slope and steepness of slope is used to determine the level of erosion protection. Sensitive areas, Regulated areas and no-work zones must be shown. Grading limits and their proximity to water features or other sensitive areas will tell the designer when to use perimeter protection or another method that will trap sediments before they reach the water. Cut and fill lines are necessary to determine whether perimeter erosion protection is required such as sediment barriers or if check dams are needed when determining how the project grading will change the existing topography at the site.

The existing and proposed storm drainage features are required so the designer can evaluate where inlet or outlet protection measures will be needed. Drainage ditches may need check dams to slow the runoff from the project site in order to settle out sediments. Water quality features need to be fitted with robust erosion and runoff controls to protect and stabilize the erodible special treatment soils during the time that vegetation is being established.

The base map should be plotted at a scale large enough to easily distinguish important features such as drainage swales and topography. The base map should include the following information:

- Alignment and stations.
- Names of roads and waterways.
- Right of Way and easements.
- Storm water drainage (culverts, pipes, etc.).
- Natural drainage features (lakes, swales, rivers, streams, wetlands, etc.).

- Cut and fill lines and expected slopes.
- Topography outside cuts and fills.
- Roadway grades.
- Extent of surrounding development.
- Detours and detour structures.

6.4 Develop Plan Sheets

The [ODOT Contract Plans Development Guide](#), has been supplanted by the [Contract Plans Manual](#). The ESCP Plan Sheets will follow the templates outlined in the Contract Plans Manual. The following is a list of items that should be included in the Agency ESCP:

Plan Sheet Checklist

- Sheet title, sheet number and “V” number
- Plan sheet (DEK.DGN and PLANS.DGN)
- ODOT flying tee logo
- Notes in the lower right corner (as sheet layout allows)
- Reference to standard drawings (if necessary)
- Signature block
- Engineer or landscape architect’s stamp (all ESCP sheets)
- Location of Best Management Practices (BMP) using standard symbols
- Erosion control construction notes and reference bubbles
- Existing ground contour lines in 1 or 2 foot increments (screening optional) with major elevations labeled
- Proposed grading contours (optional)
- Cut and fill lines and topography outside cuts and fills
- Erosion control BMP’s, relative to construction staging (optional)
- Alignment showing line labels and stationing ahead on line
- Place names including roads and all waterways
- Right of Way and easements
- Storm water drainage system (culverts, pipes, inlets)
- Natural drainage features (lakes, swales, rivers, streams, etc.)
- Arrows indicating drainage patterns and flow directions
- Show boundaries of environmentally sensitive areas such as wetlands, burial grounds, etc.

- Location and names of Best Management Practices (BMP) including aggregate construction entrances
- Delineation of clearing limits
- Construction notes for each plan sheet giving construction directions
- North Arrow on each plan sheet
- Legend of ODOT standard symbols actually used per plan sheet
- Existing structures

6.4.1 Erosion Control Construction Notes

The boilerplate language for the construction notes is found in the cache of erosion control cells that provides typically used symbols accessed in Microstation. The cache can be accessed through the tab “element” and then “cells”. (See Chapter 8 of the Contract Plans Manual). The Construction Notes should be put on the first ESCP plan sheet. Use only the paragraphs that are pertinent to the plan. For example, when aggregate construction entrances are not used in the plan, the final paragraph must be deleted from the construction notes. Also, if sediment fences are not used on the project, delete the paragraph that pertains to sediment fence. The designer may add language in the construction notes to direct the contractor or to further explain the ESCP.

GENERAL NOTES:

The construction, adjustment, maintenance, and upgrade of these Erosion and Sediment Control measures is the responsibility of the contractor for the duration of the project to comply with Section 00280 of the Oregon Standard Specifications for construction and the NPDES 1200-CA permit

Erosion and Sediment Control measures shown on this plan are for anticipated site conditions. Adjust or upgrade these measures for unexpected storm events to ensure that sediment and sediment-laden water does not leave the site.

Develop a revised plan for the Erosion and Sediment Control measures shown as required by Section 00280, Oregon Standard Specifications for Construction. Implement this plan for all clearing and grading activities and in segments applicable to each staging phase. Construct in such a manner so as to ensure that sediment and sediment-laden water does not enter the roadway or drainage system, or violate applicable water standards.

Install measures within the right-of-way unless directed otherwise.

6.4.2 Erosion Control Legend

The ESCP and construction legend should meet the same standards as given for the roadway portion of the plans. Show in the legend only the items that are included in the ESCP design.

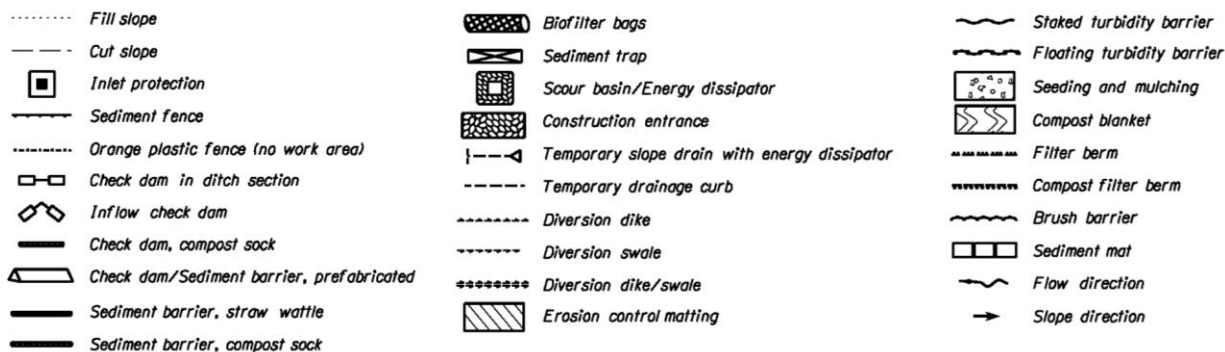


Figure 6-2 EROSION CONTROL LEGEND

6.4.3 Plan Sheet Format

In the project plan set the Agency ESCP is usually its own section numbered in the convention of the Contract Plans Manual. Erosion and Sediment Control Plans are the FB series, being numbered: FB01, FB02 etc. On small projects with little ground disturbance the erosion and sediment control BMPs may be included in the roadway construction plans.

The ESCP is normally a separate section of the contract plans and is 11" X 17" sheet size as is most common for contract plans developed in the ODOT Roadway Section. The detail sheets follow the plan sheets in the erosion and sediment control section. Each plan and detail sheet will all have a professional of record's stamp. The sheets in the ESCP set will also include the name of the drafter, designer and the reviewer.

ESCP sections of the Project Plans are required to begin with a Cover Sheet. The Cover Sheet is required by the NPDES 1200-CA permit with the purpose being to provide the regulatory agency, DEQ, with an easy summary of the construction project and the erosion and sediment control BMPs used. A [template for the Cover Sheet](#) will be available on the ODOT Erosion and Sediment Control web page in the "Guidance Materials" box. The Cover sheet will include the following:

- Erosion and sediment control notes;
- Site name and location information
- Monitoring requirements
- Site map
- Vicinity map
- Names of all personnel involved in the design and implementation of the ESCP
- Summary of project work
- Overview of project site
- Work schedule
- Legend of symbols
- Sheet index
- Professional stamp

The ESCP Plans must provide a separate sheet, or series of sheets, for each phase of construction. When applicable phased plans would follow the sequence of: a) Demolition, clearing grading, excavating and land development. b) Streets and utilities; c) Vertical construction; d) Final landscape and site stabilization. For linear construction projects, which are typical for ODOT work, phasing sequence follows each distinct area of disturbance. Phases of construction are often (but not always) identified in the Traffic Control Plans. ESCP designer should coordinate with roadway design engineer to understand and identify the sequence of work and nature of work at each phase of construction and provide comprehensive plans that address risk during each phase of work.

The ESCP can have the following formats:

- 11 X 17 sheets with a separate ESCP section in the plans addressing each phase of construction.
- 11 X 17 sheets with the ESCP incorporated into the Roadway plans addressing each phase of construction.
- Table of Locations addressing each phase of construction.

In the event that the ESCP is not too complicated and the roadway plans can accommodate additional items without appearing confusing, the erosion control items can be placed on the roadway construction plans. It is important to include a legend that reflects the erosion control items. In this case, the construction notes should be on the first erosion control page of the first standard detail sheet.

6.4.4 Table of Location Plan Sheet Format

Although this ESCP format is rarely used, when the project is long and the need for erosion control best management practices is limited to sporadic locations this format is effective. At a minimum, the ESCP must include the table of location, the erosion control construction notes, and the details for each best management practice called for on the table of locations. The table of locations must include the location where the erosion control method is needed. The locations should be noted using English stationing as provided on the Roadway General Construction sheets. The erosion control item is listed by station as well as which side of the road that it should be installed. A *Lt.* is used for left or *Rt.* for right by increasing station. The page number reference for the corresponding plan sheet displaying the detail or the Standard Drawing reference should also be included. Below is an example of an ESCP table of locations.

Table 6-4 EROSION SEDIMENT CONTROL PLAN TABLE OF LOCATION

Station	(L/R)	Erosion Control BMP	Quantity	Plan Sheet
"L" 1+61 – 1+75	Lt.	Sediment Fence		FB02
"NB" 1+65	Lt.	Inlet Protection, Type 3	2	FB02

Station	(L/R)	Erosion Control BMP	Quantity	Plan Sheet
"L" 1+79 -	Rt.	Inlet Protection, Type 3	2	FB03
"L" 0+98 to "L" 1+99	Lt.	Sediment Barrier, Type 8	101'	FB04
"L" 1+14 to "L" 1+18	Lt.	Sediment Fence	4'	FB06
"NB" 1+32	Rt.	Inlet Protection (Type 3)	1	FB06
"L" 1+94 to "L" 1+96	Rt.	Sediment Fence	2'	FB07

6.5 Designer Tools

6.5.1 Soil Survey Information

The [USDA's Natural Resource Conservation Service \(NRCS\)](#) has soil surveys available on line. The NRCS has the soil surveys organized by county. The county soil survey contains a lot of information useful for any land-planning program. Of prime importance are the predictions of soil behavior for selected land uses. Great differences in soil properties can occur even within short distances. Soils may be seasonally wet or subject to flooding. They may be shallow to bedrock.

These and many other soil properties that affect land use are described in the soil survey. Broad areas of soils are shown on a general soil map. The location of each kind of soil is shown on detailed soil maps. Each kind of soil in the survey area is described, and much information is given about each soil for specific uses. Additional information or assistance in using this publication can be obtained from the local office of the Natural Resource Conservation Service. The [NRCS county offices](#) are listed on their web page.

6.5.2 Contract Plans Development Guide/Contract Plans Manual

The [Contract Plans Development Guide \(CPDG\)](#) has been phased out. It has been replaced with the [Contract Plans Manual](#). Sheet order has Erosion and Sediment Control sheets after Roadside Development Sheets. Erosion and Sediment Control Plans are numbered in the FB series (e.g. FB01, FB02...) right after the FA series. ODOT provides final plans electronically as PDFs with digital signatures. ODOT uses a file management for our graphic files (plans) that is centralized in the ProjectWise file management system. Drafting is done in Microstation™.

The Contract Plans Manual outlines the organization and structure of Contract Plans and provide comprehensive guidance for the organization of drawings and drafting standards.

6.5.3 Hydraulics Manual

The [ODOT Hydraulics Manual](#) is available from the Geo-Environmental Unit's Practices & Standards Unit. This manual provides practices and procedures used by ODOT for the hydraulic design of highway facilities. Within this manual there is a wealth of resources that can be valuable in planning erosion and sediment control plans. Among the resources are topographic data, 24-hour precipitation maps and information about stormwater treatment. It is worthwhile for Erosion and Sediment Control Designers to be familiar with its contents.

6.5.4 Precipitation Data

The occurrence and amounts of rainfall is important for the designer when deciding to what extent the erosion control measures must be used. During construction, the contractor must monitor the rainfall onsite using a rain gauge. Precipitation data may be found by contacting the [National Weather Service](#). This web site provide multiple tabs and a search engine to provide information on temperatures, wind direction, relative humidity, and precipitation all over the United States including the Oregon Coast and Pacific Northwest.

6.5.5 Internet Sites

[Oregon Seed Certification Service](#)

[Natural Resource Conservation Service](#)

[International Erosion Control Association](#)

[Qualified Products List:](#)

[TXDOT Erosion Control](#)

[ODOT FTP Site](#)

[ODOT Standard Drawings](#) Erosion & Sediment Control 1000 Series

[ODOT Standard Details](#) Erosion & Sediment Control 6100 Series

[Roadside Development Manual](#)

6.6 Cost Estimate

The ESCP designer prepares a quantity and cost estimate for specific erosion control best management practices included in the ESCP. The designer must compile a list of all erosion control bid items and estimate a cost for each of the bid items.

A project cost estimate normally includes a lump sum bid item called "Erosion Control". This item is for developing and updating the Erosion and Sediment Control Plan (ESCP) required in

section 00280, and also covers any additional work required but not included in the Bid Schedule, including monitoring and reporting on BMP's and providing an Erosion and Sediment Control Manager (ESCM). When developing the cost estimate follow the format provided in the ODOT [Bid Item List](#). The bid item list provides the ODOT item number, the exact language to be used in naming the item and the unit of measure associated with each item. Following the example provided in the bid item list simplifies work for specifications technician and design engineer who compiles cost estimates from all disciplines. An example of the (current) estimate format is provided on the following page. Get a copy of the roadway engineer's spreadsheet to use in developing the erosion and sediment control estimate.

It is important that every item the designer specifies, be it a work item or a product, is included in the cost estimate. The cost estimate is a component of the contract that is used as a list of the tasks for the contractor. If work is not listed, it may need to be added to the project by a change order. ODOT wants to minimize the use of change orders.

Roberts Hill Climbing Lanes		http://touchmap.com/atlong.html		How to select L		
Bid Item Number	ITEM	Latitude	Longitude	UNIT	AMOUNT	UNIT COST
		4D^ MM'	12D^ MM' SS"			
Erosion and Sediment Control						
0210-010000A	MOBILIZATION			LS	All	2.00%
0280-010000A	EROSION CONTROL			LS	All	10000.00
0280-0104020R	TEMPORARY MULCHING, STRAW			ACRE	10	\$1,400.00
0280-0105040J	MATTING, TYPE D			SQYD	1251	\$3.50
0280-0105050J	MATTING, TYPE G			SQYD	81835	\$3.50
0280-0106010E	CHECK DAM, TYPE 1			EACH	194.0	\$175
0280-0106060E	CHECK DAM, TYPE 6			EACH	10.0	\$175
0280-0108000E	TEMPORARY SLOPE DRAIN			EACH	3	\$250.00
0280-0109000F	FLOW SPREADER			FOOT	0	\$12.00
0280-0110010E	CONSTRUCTION ENTRANCE, TYPE 1			EACH	3	\$2,000.00
0280-0113000F	SEDIMENT FENCE			FOOT	700	\$2.80
0280-0114030E	INLET PROTECTION, TYPE 3			EACH	72	\$80.00
0280-0114030E	INLET PROTECTION, TYPE 4			EACH	15	\$80.00
0280-0115030F	SEDIMENT BARRIER, TYPE 3			FOOT	200	\$5.00
0280-0115080F	SEDIMENT BARRIER, TYPE 8			FOOT	6164	\$5.00
0280-0117000E	FLOCCULANT			EACH	4	\$500.00
0280-0117000E	TEMPORARY ENERGY DISSIPATER			EACH	4	\$500.00
0290-0200000A	TURBIDITY MONITORING			LS	1	\$1,500.00
0280-0107000F	TEMPORARY INTERCEPTOR DIKE/SWALE			FOOT	861	\$5.00
1030-0109000R	PERMANENT SEEDING, MIX NO. 1			ACRE	6.7	\$4,500
1030-0110000R	PERMANENT SEEDING, MIX NO. 2			ACRE	41.6	\$6,000
1030-0111000R	PERMANENT SEEDING, MIX NO. 3			ACRE	0.0	\$3,500
1050-0105000F	TYPE 2 MODIFIED FENCE			FOOT	2100	\$5
EROSION CONTROL SUBTOTAL						

Figure 6-3 Bid Item List

6.7 Specifications

The Specifications are the [Oregon Standard Specifications for Construction 2018](#). These are contract documents that provide baseline direction to contractors and provide project manager enforcement tools to keep the contractors compliant with project requirements. When designs

deviate from the Standard Specifications those changes are provided in Special Provisions. The Specifications and Special Provisions are tightly organized. For erosion and sediment control special provisions the system of order is as follows:

- Scope or description of work is in 00280.00 to 00280.09
- Specified materials are described in 00280.10 to 00280.19
- Specialized equipment requirements are in 00280.20 to 00280.29
- Labor or skills certifications are in 00280.30 to 00280.39. This subsection includes the list of responsibilities and duties of the contractor's Erosion and Sediment Control Manager (ESCM).
- Construction is in 00280.40 to 00280.59
- Maintenance requirements are in 00280.60 to 00280.69
- Scope or description of work is in 00280.00 to 00280.09
- Finishing, cleanup and warranties are in 00280.70 to 00280.79
- Measurement is provided in 00280.80 to 00280.89
- Payment is described in 00280.90 to 00280.99

The Special Provisions add, delete or revise information provided in the Specifications. Special Provisions have a higher order of precedence than the Specifications, meaning they have greater authority than the Specifications. Special Provisions begin as [Boilerplate Special Provisions](#) which are the word document templates for editing. Always begin with a new Boilerplate because they are regularly updated. The Boilerplate Special Provisions are structured with instructions for editing. Edits to these are conducted in track changes mode and the writing style is conducted in the "imperative mood". The imperative mood directs the subject (contractor) to do things with clear, simple language. The Specifications do not expressly direct the contractor. It is implied the contractor is the subject of directives. The writing style is easy to adopt and important to follow. For guidance in following this writing style review the short and simple [Specifications and Writing Style Manual](#). It provides good advice for all writing.

The designer develops and is responsible for the Special Provisions for the Agency ESCP. The Specifications or Special Provisions must reflect each best management practice found in the ESCP and some items that are not shown on plans but may be needed as emergency materials. Special Provisions may contain additional information about materials, construction, maintenance, and payment. Special provisions are used to make changes to the standard specifications on a job-by-job basis.

The designer and the construction staff should be familiar with each portion of sections 00290, 00280, and 01030 of the specifications (Standard and Special Provisions).

6.7.1 Erosion Control – Section 00280

Erosion control measures are a part of work required on all construction projects which disturb soil (greater than 1 acre). Section 00280 of the specifications have been developed to satisfy the requirements of regulatory requirements, including the 1200-CA Permit. Section 00280 describes the contractor's responsibilities related to the erosion control for the project. The work

for installation, maintenance, inspection, and removal of each BMP is included in payment for the pay item for the specific BMP. Some BMP's are included in the lump sum pay item "Erosion Control." Unit measure pay items are preferred over lump sum because it reduces the risk to the contractor, generally yields more reasonable costs, and makes quantity adjustments in the field easier to negotiate.

6.7.2 Pollution Control – Section 00290

Pollution Prevention Measures are a part of work required on all construction projects. Section 00290 of the specifications describes the contractor's responsibilities related to the prevention of pollution of water and land. The Pollution Control Plan requirements are described in the 00290 Section. Also included in the 00290 Section are protections of wildlife, historic and archeological and cultural resources.

6.7.2.1 Specific BMP's

In the ODOT Specifications many best management practices are listed by what they do, not what they are made of. For example, Sediment Barrier, Type 2 is constructed from biofilter bags, Inlet Protection, Type 4 is biofilter bags and Check Dam, Type 3 is also made from biofilter bags. These BMPs are all made from biofilter bags, but are listed by the function they perform. Other pay items may be listed by the product, for example Plastic Sheeting or Matting. The Bid Item List provides unit of measure and the Special Provisions includes units of measure for (at least) one emergency material, Straw Bale. The pay items as listed in the 00280.90 section of the Standard Specifications include:

<u>Pay Item</u>	<u>Unit of Measurement</u>
Erosion Control	Lump Sum
Plastic Sheeting	Square Yard
Chemical Soil Binder	Acre
Chemical Dust Control	Acre
Temporary Mulching (Hydromulch, Straw and Compost)	Acre
Matting (Types A through H)	Square Yard
Compost Erosion Blanket	Square Yard
Check Dam (Types 1 through 6)	Each
Temporary Interceptor Dike/Swale	Foot
Temporary Slope Drain	Each or Foot
Flow Spreader	Foot
Compost Filter Berm	Foot
Construction Entrance (Types 1 through 3)	Each
Tire Wash Facility (Types 1 and 2)	Each
Concrete Washout Facility	Each
Sediment Fence	Foot
Inlet Protection (Types 2, 3, 4, 6, and 7)	Each
Sediment Barrier (Types 2 through 9)	Each or Foot

Sediment Mat	Square Yard
Temporary Energy Dissipater	Each
Temporary Sediment Trap	Each

If required products or work items are needed for the project but not listed, they must be added. Each relevant aspect of the added feature must be described within the subsection number described [above](#) regarding specification organization. For example: if a sediment filter bag (Dirt Bag) is required, it would be described in the dot-teen subsection, the placement and use would be described in the dot-thirty subsection, removal would be described in the dot-seventy subsection and of critical importance the units of measure and payment would be described in the dot-eighty and dot-ninety subsections.

6.7.2.2 Erosion Control

Erosion Control is a lump sum pay item that is required on all jobs. Many important tasks are paid for by this pay item and it should not be ignored or minimized when preparing an engineer's estimate or bid for a construction contract. If this pay item is not included in the contract, all work described below is considered incidental and no separate payment is made. The major tasks include:

- Providing a qualified individual as an Erosion and Sediment Control Manager (ESCM).
- Developing, revising and documenting the Erosion Control Plan (ESCP).
- Mobilization of crews to address ESC needs.
- Monitoring activities to maintain effective functioning.
- Furnishing, stockpiling, protecting, restocking and removing emergency materials.
- Preparing Project for a period of extended non-activity.
- Inspecting, maintaining and removing erosion control devices.
- Turbidity monitoring
- Restoring, mulching, tacking and seeding all disturbed ground, Work and storage areas not otherwise covered.

6.7.3 Seeding – Section 01030

[Seeding](#) is a part of work required on all construction projects where disturbed soil is anticipated. Section 01030 of the specifications describes the contractor's responsibilities related to seeding, fertilizing, mulching, and any specified soil testing operations that are necessary for vegetation establishment. An important part of seeding is the selection of the appropriate seed mixtures and rate of application. Each job may have unique soil, climatic, or other environmental conditions, so it is recommended to contact a qualified Landscape Architect, agronomist, horticulturist, or erosion control specialist for recommendations. ODOT specifications require the designer to specify seed mixtures and rates of application. The final performance criteria such as

vegetative coverage requirements and time allowed to achieve that coverage is provided in the Standard Specifications.

The pay items, which are available for specific seeding applications, include:

<u>Pay Item</u>	<u>Unit of Measurement</u>
Weed Control	acre
Seeding Mobilization	each
Temporary Seeding	acre
Permanent Seeding	acre
Wetland Seeding	acre
Water Quality Seeding	acre
Plant Seeding	acre
Native Plant Seeding	acre
Wildflower Seeding	acre
Lawns Seeding	acre or ft. ²
Fertilizing	acre
Mulching	acre

Seeding, fertilizing, and mulching are often combined into one operation. In these cases a single "Seeding" pay item may be used that is explained in the special provisions as including other materials as part of the operation.

6.8 Narrative

For more complex projects, a narrative is included in the project file and may also become part of the plan when necessary to explain the ESCP in greater detail. The narrative should be brief, clear and concise while stating pertinent information. A detailed narrative should include design dates, expected rainfall, expected runoff velocities, expected peak flows, soil types, total project area and total disturbed area. It should discuss any particular concerns related to the project ESCP including special environmental and jurisdictional requirements, steep slopes, highly erodible soils, etc. and how the concerns are addressed. Less detailed narratives are usually acceptable that describe erosion and sediment control in more sweeping terms.

The Erosion and Sediment Control designer will be providing the narrative only for the information in their scope of work. General information, such as project area may already be provided elsewhere in the narrative document.

Narrative Checklist

- Estimated total project area (acre)
- Estimated total disturbed (acre)
- Surficial soil types and erodibility (Soil Conservation Service K value)
- Runoff coefficients for disturbed areas
- Estimated peak flows for the design storm runoff
- Receiving waters

- Jurisdictions within the project limits
- State and local requirements incorporated into the plan
- Special environmental considerations related to storm water runoff
- Anticipated concerns, or possible problems
- Information sources and/or contacts

6.9 Project Design Phases

In ODOT, Regions are responsible for the development of projects. The following are the major project development phases used by ODOT and a brief summary of typical erosion control-related tasks for each phase (for projects with significant ground disturbance):

6.9.1 Project Planning and scoping

- Estimate erosion control needs based on the type of project, type and amount of disturbance impacts anticipated, and project environmental setting.
- From above, estimate level of effort required for erosion control preliminary engineering (design and associated).
- Understand that the requirement for ESCP sheets for each phase of construction will increase ESCP design costs.
- Using budgeting guidelines, estimate a dollar figure for cost of constructed items.
- Plan for the time, labor, and budget resources needed to perform the work.
- Incorporate scoping results into general project planning.

6.9.2 Design Acceptance Package (DAP)

- Establishes geometric boundaries and project footprint
- Roadway design strategy is established
- Access management and Traffic design are strategized.
- Environmental studies and Geo/Hydro site analysis.
- Right of Way development.
- Permits and clearances tasks
- Design acceptance review.
- Draft DAP.

6.9.3 Preliminary Plans

- Confirm that a designer has been assigned for erosion control.
- Monitor general project design decisions with any potential for affecting erosion-related impacts. The goal is to eliminate or minimize impacts where feasible. Attend Project Delivery Team (PDT) meetings.
- Adapt copies of Roadway base sheets for erosion control plans. Where applicable, Traffic Control Plans can provide a template for displaying each distinct phase of construction and ESCP.

- Incorporate into base sheets all critical information such as topography, vegetation and natural buffers between Project and waterways.
- Begin development of Erosion and Sediment Control plans.
- Coordinate ESC plans with Preliminary Roadway, Drainage and Utility plans and other general construction plans including any structures, staging, or other areas of work.
- Coordinate with Roadway Designer and Traffic Control Plan designer to develop phased erosion and sediment control plans
- Perform on-site analysis of risks and opportunities.
- Get peer review from qualified erosion control designer.

6.9.4 Advance Plans

- Respond to comments made during Preliminary Plans distribution.
- Begin erosion control design (if not begun in previous phase) and coordinate ESC plans with other design and engineering disciplines.
- Ensure that all relevant information has been collected for design including relevant environmental documents such as the Biological Assessment or unique permit requirements.
- Analyze project for erosion-related, runoff-related or sediment control-related impacts from all areas of design and all phases of construction.
- Coordinate Plans, Estimate & Special Provisions
- Visit site to confirm data and review site conditions.
- Select initial BMPs to mitigate for disturbance impacts.
- Finalize BMPs and complete plans, specifications, and estimate.
- Get peer review from qualified erosion control designer.
- Provide ESCP to DEQ to start their file for the Project. Submittal is not for review.

6.9.5 Final Plans

- Respond to comments made during Advance Plans distribution.
- Update base sheets and revise design and plans as required.
- Prepare final set of contract documents, submit for final review.
- Affix electronic Stamp to Contract Documents in compliance with state requirements and provide digital signature as approved by State Landscape Architect's Board.
- Ensure that designer is available to respond to questions throughout bidding period.

Chapter 7 - CONSTRUCTION

Erosion and sediment control measures are necessary on construction sites because they are required as conditions of permits, because they protect natural resources and because they are contract requirements that diminish risk to the Agency. The compliance with the permits is enforceable by law. Inspection of erosion and sediment control measures is necessary to ensure proper installation, continued maintenance and effective functioning.

7.1 Erosion and Sediment Control Manager

The way ODOT's erosion and Sediment Control Plan is put to use on projects is that the contractor is the primary agent in dealing with erosion and sediment control issues during construction. The contractor provides an Erosion and Sediment Control Manager (ESCM) as their lead person for erosion and sediment control. That person must be experienced in all aspects of construction and qualified to design and inspect erosion control plans and facilities. At a minimum, the ESCM must have certification verifying completion of a class on erosion control that covered all the items included in this manual. Acceptable courses for ESCM certifications are as follows:

- [ODOT ESCM training](#)
- Certified Professional in Erosion and Sediment Control ([CPESC](#))
- Certified Professional in Storm Water Quality ([CPSWQ](#))
- Washington Department of Ecology's Certified Erosion and Sediment Control Lead ([CESCL](#)) Certification
- [Rogue Valley Sewer Services Erosion and Sediment Control Certification](#),

The ESCM is responsible for assuring the implementation of the ESCP and have the authority to immediately mobilize necessary personnel to correct and modify erosion prevention and sediment controls if required. ODOT remains the permit holder and is ultimately responsible for compliance with the conditions of the NPDES 1200-CA permit, so ODOT inspectors verify the ESCM's performance.

Duties of the EPCM include:

- Manage and ensure proper implementation of the ESCP.
- Accompany the Engineer during field review of the ESCP prior to construction activities.
- Monitor rainfall on and in the vicinity of the Project Site.
- Monitor water quality in receiving streams in the vicinity of the Project Site.
- Monitor sediment traps receiving runoff from soils amended with cementitious material for pH.
- Inspect ESC and monitor receiving waters on active construction site on initial date and every 14 Days for effective functioning.
- Inspect ESC on inactive sites every 14 Days for effective functioning.
- Inspect ESC for effective functioning and monitor receiving waters, on all active and inactive sites at least within 24 hours of rainfall events sufficient to result in runoff.
- Ensure that ESC are regularly cleaned and maintained.

- Mobilize crews to make immediate repairs to ESC or install additional ESC during working and non-working hours when ESC is not effectively functioning.
- Record actions taken to clean up significant amounts of sediment.
- Report potential permit violations to the Agency in a timely manner.
- Regularly
- Per the inspection schedule, fill out the approved ESC Monitoring form ([Form 734-2361](#)).
- Update the ESCP monthly and within 24 hours after changes or major ESC modifications are implemented.
- Prepare a contingency plan in preparation for emergencies and the rainy season.
- Accompany the Engineer on inspections and, if required, on inspections by representatives of regulating agencies. If any of the following occur, revise the ESCP to reflect the change(s) within 7 Days.
 - Changes to the construction plans that impact erosion and sediment control measures.
 - Changes to the stormwater control BMPs, their location, maintenance required, and any other revisions necessary to prevent and control erosion and sediment runoff;
 - An increase in construction activities to adjacent lots;
 - Other activities at the site that are no longer accurately reflected in the ESCP. This includes changes made in response to corrective actions triggered;
 - To reflect areas on the site map where operational control has been transferred (and the date of transfer) since initiating permit coverage;
 - If inspections by DEQ determine that ESCP revisions are necessary for compliance with this permit;
 - Where DEQ determines it is necessary to install or implement additional controls at the site in order to meet the requirements of this permit. Include the following in the ESCP:
 - A copy of any correspondence describing such measures and requirements; and
 - A description of the controls to be used to meet such requirements.
 - Change of Contractors that will engage in construction activities on site, and the areas of the site where the Contractor(s) will engage in construction activities;
 - Change of any personnel (by name and position) that are responsible for the design, installation and maintenance of stormwater control measures;
 - Change of the certified erosion and sediment control inspector, or of their contact information and any applicable certification and training experience;
 - To reflect any revisions to applicable federal, state, tribal, or local requirements that affect the stormwater controls implemented at the site; and
 - If a change in chemical treatment systems or chemically enhanced stormwater control is made, including use of a different treatment chemical, different dosage rate, or different area of application as applicable. Furnish temporary sediment trap as shown on drawings, stamped and signed by licensed engineer.

Ineffective Controls

The ESCM shall record measures taken to clean up significant amounts of sediment. Should a control measure not function effectively, one for more of the following tasks should be performed:

- Immediately repair the control.
- Replace the control.

- Provide additional controls.
- Document the sediment discharge, the cleanup and modifications to the ESC facilities.
- Report sediment discharge to Project Engineer.

7.1.1 Rainfall Monitoring

The ESCM shall furnish and install a rain gauge at the project site and monitor rainfall. When any 24 hour weather event results in stormwater runoff leaving the site (or snowmelt leaving the site), notify the Agency and inspect the project site to evaluate the condition of the control measures as soon as is practicable, but no later than 24 hours, including weekends and holidays.

7.2 Pre-Construction Meeting

The contractor and inspector should carefully review the ESCP prior to the pre-construction meeting to understand what is required. The contractor shall revise the ESCP prior to the start of construction to provide information such as personnel and schedule information that was unknown during design. Implementing the ESCP and assuring its performance may involve significant expense. The following pre-construction activities should be required:

- Prior to the pre-construction meeting, review and comment on the contractor-modified ESCP or contractor proposed ESCP modifications.
- The 1200-CA permit will be provided to the Contractor.
- During The pre-construction meeting provide an opportunity for the contractor to discuss the plan with the inspector, review the comments and finalize the ESCP implementation schedule.
- Prohibit clearing and grading operations prior to ESCP approval and implementation.
- Tentatively locate construction accesses.
- Delineate clearing limits, drainage courses, easements, setbacks, wetlands and other sensitive or regulated areas and their buffers.
- Adjustments to improve performance or make installation easier and maintenance more reliable may also be discussed.

The pre-construction meeting is also an opportunity to discuss the inspection schedule and procedures. Additional key points to consider in the pre-construction meeting are:

- Pollution Control Plan for contractor operations.
- Qualifications of individual designated as the ESCM.
- Method to be used to document the up-to-date ESCP.
- Adjacent areas that need special protection from sedimentation, particularly environmentally sensitive areas such as wetlands, stream crossings, channel, and water disposal outlets. Steep slopes are areas that need special protection from erosion.
- Location of erosion and sediment control practices and their implementation.
- Sequence of installation with respect to the construction schedule.

- Surface stabilization plans, temporary and permanent seeding.
- Construction schedule and any anticipated shutdown periods such as work suspension during wet season.
- Maintenance plans and the contractor's procedure for monitoring performance.
- Location of all borrow and disposal areas.
- Emergency or contingency plans.
- Any special requirements identified in permits.
- Monitoring Form submittal requirements, provide a copy of the monitoring form to the contractor and provide location of form on ODOT's web page.
- Biological Opinion – this is furnished by ODOT and covers special needs and concerns for threatened and endangered species on the project. The contractor should be made aware of its contents.

7.2.1 Contractor-Modified ESCP

Most Contract Plans will include the Agency ESCP prepared by designers. Erosion and sediment control designers cannot know a contractor's means and methods or their schedule so the Agency ESCP unlikely to have addressed all erosion concerns for the project adequately. The Agency ESCP should be used as the basis for the Project ESCP and not be followed blindly. It is the contractor's responsibility to propose, implement and document modifications to the plan. The modifications can be marked on the ESCP included in the plan set and submitted to the Agency. The Project Manager or Agency reviews and comments on the contractor-modified ESCP. In order to assess the adequacy of the ESCP, the reviewer should ask the questions listed below. The plan should include a brief narrative describing any unique site characteristics or special considerations. Sufficient detail should be provided to implement the plan properly and control erosion and sedimentation during each phase of site development.

1. Does the ESCP satisfy the requirements in the 1200-CA Permit and the 00280 Specifications?
2. Is the information site specific? Any information provided by the contractor for the ESCP must be site and project specific rather than generic.
3. Does the ESCP fulfill the following minimum requirements (when applicable)?
 - Show protection and buffers for sensitive areas, streams, lakes, and wetlands?
 - Protect adjacent properties and protect downstream properties and waterways from erosion by control velocity and volume of runoff as it leaves the site?
 - Prevent upslope runoff from flowing over disturbed areas?
 - Provide measures which trap sediment onsite?
 - Route dewatering devices through a sediment-trapping device before leaving site?
 - Protect inlets and the storm drain system?
 - Provide perimeter protection downslope and along the full length of disturbed areas?
 - Provide erosion prevention for steep slopes?
 - Provide protection at cut and fill slope transitions?

7.2.2 Up-to-Date ESCP

Effective erosion control is closely tied to a contractor's staging, operation methods, and construction timing. When ODOT develops the erosion control plan, the contractor's staging and operation methods are unknown. Therefore, ODOT expects the contractor to propose changes to the ESCP and update the plan as needed throughout the life of the project.

Changes to the ESCPs are the responsibility of the ESCM. Contractor's ESCM submits changes to the ESCP Agency for approval. The modified ESCP will be documented using procedures approved by the Agency. Generally, changes to the ESCP can be made by hand on the plan itself, however electronic drafting and editing programs are acceptable. Revised ESCP will become a master up-to-date ESCP. It is required that the ESCP be updated at least monthly and when triggered by any of the following:

- Changes to the construction plans that impact erosion and sediment control measures.
- Changes to the stormwater control BMPs, their location, maintenance required, and any other revisions necessary to prevent and control erosion and sediment runoff.
- An increase in construction activities to adjacent lots.
- Other activities at the site that are no longer accurately reflected in the ESCP. This includes changes made in response to corrective actions triggered under Section 16. The ESCP does not need to be modified if the estimated dates in Section 15.4.e.viii change during the course of construction.
- To reflect areas on the site map where operational control has been transferred (and the date of transfer) since initiating permit coverage.
- If inspections by DEQ determine that ESCP revisions are necessary for compliance with this permit.
- Where DEQ determines it is necessary to install and/or implement additional controls at the site in order to meet the requirements of this permit, the following must be included in the ESCP:
 - A copy of any correspondence describing such measures and requirements; and
 - A description of the controls that will be used to meet such requirements.
- Change of contractors that will engage in construction activities on site, and the areas of the site where the contractor(s) will engage in construction activities.
- Change of any personnel (by name and position) that are responsible for the design, installation and maintenance of stormwater control measures (see Section 15.10).
- Change of the Certified Erosion and Sediment Control Inspector (ESCM), or of their contact information and any applicable certification and training experience.
- To reflect any revisions to applicable federal, state, tribal or local requirements that affect the stormwater controls implemented at the site.
- If a change in chemical treatment systems or chemically enhanced stormwater control is made, including use of a different treatment chemical, different dosage rate or different area of application as applicable.

When site conditions require that BMP be installed that were not anticipated, revisions to the ESCP must be made within 30 days of the revision. An example of an updated up-to-date ESCP

is provided in Appendix C. Notes on the up-to-date ESCP should indicate the location, date, and status of each BMP (I=installed, M=maintained, R=removed).

7.2.3 Construction Schedule Review

Refer to Sections 00290.30(c), 00180.41 and 00280 for specific requirements. The implementation schedule should include the following:

- Timing of activities to limit seasonal and weather impacts.
- Timing of wet season work (October 1 – May 31) and temporary work shutdown.
- Timing of activities to meet “in-water” work restrictions.
- Install erosion prevention and sediment controls shown on the plans before ground-disturbing activities begin (00280.40)
- Permanent facilities, such as sediment traps and basins, which will be used during construction as temporary measures should be installed.
- Temporary stabilization / erosion prevention
- Retention of temporary perimeter controls until all upstream areas are finally stabilized.
- Timing of seeding operations.

7.2.4 Monitoring Form

All inspections are to be recorded on the ODOT [Erosion Control Monitoring form \(734-2361\)](#) which is included in Appendix E. The form is an interactive PDF with expandable fields that enlarge as content is added. The form includes boxes where photo documentation is to be inserted. The ODOT form also uses DocuSign for digital signatures that verify the identity of the signer and the date of the signature. The inclusion of digital photographs is an excellent practice and is required to demonstrate success of corrective actions. Contractor’s ESCMs must provide honest evaluation of BMPs on monitoring forms. Falsification of monitoring forms is a Class C felony, punishable by up to \$100,000 in fines. ESCMs found to falsify a monitoring form will have their ESCM certification revoked. ODOT, as always, is the permittee and ODOT’s oversight of ESCM’s monitoring reports is important in maintaining Permit compliance.

The effectiveness of each BMP at every location on site should be documented on the form, and general observations on site conditions should also be recorded. Information provided on the form is useful for tracking repairs and demonstrating permit compliance. It is noteworthy that in the event of permit violations or subsequent enforcement actions, the information recorded on the form, along with photographs and videos, may be used to evaluate the responsibility of involved parties.

7.3 Materials

The following sections present information on erosion and sediment control products and materials approved for use on ODOT projects. Information necessary to verify proper Quality Control /Quality Assurance in accordance with the specifications is also provided.

7.3.1 ODOT Qualified Products List (QPL)

The [ODOT Qualified Products List](#) (QPL) is for products that have been reviewed and found to be suitable for use in a specific category. Erosion control products are found in Section 00280 of the QPL. Job control testing may still be necessary.

Approved List – commercially available products having a low consequence of failure, products may be used for appropriate applications only.

Rejected List – products that should not be used for that specific category.

Conditional List (unpublished): conditionally approved products that require specific approval for each application.

Specific questions regarding products on the Conditional List can be answered by calling the New Products Coordinator, Construction Section, ODOT materials Laboratory or the [Technical Expert](#) for Erosion and Sediment Control.

7.3.2 Sustainability

Products made with plastic unless specified as permanent features must be removed from the landscape once stabilization is achieved and properly disposed of. This removal of materials may itself cause soil disturbance. Many types of erosion and sediment control products are fully biodegradable. ODOT requires that the 5 lightest grades of rolled erosion control products (matting) be fully biodegradable. Some matting types stitch random fiber, such as straw, between monofilament plastic netting. This netting persists in the landscape and has been shown to trap and eventually kill small animals. Enclosing mesh for straw wattles is also required to be fully biodegradable. For compost socks fully biodegradable mesh is not required, but biodegradable mesh is available and listed on the QPL. Fully biodegradable sediment barrier products function as well products that contain plastic but they do not leave plastic in the landscape, they do not add to the waste stream, they do not require the time and labor to remove them from a project site and they do not incur the cost of disposal. However, biodegradable products such as compost socks or wattles are often not sufficiently robust to hold together if they need to be relocated, or removed intact. Biodegradable wattles and compost socks will continue to function even as they break down and where removal is not going to be necessary, such as long slopes, they are an attractive alternative to plastic enclosed products. ODOT encourages the use of fully biodegradable erosion and sediment control products where their use is appropriate.

7.3.3 Seed Tags

Seed furnished for a project must meet or exceed the requirements of the Standard Specifications in Section 01030. An important requirement is meeting state and federal seed law which, among other things, spells out exact seed labeling requirements. (See [Oregon Revised Statute 633.520](#)). The following are typical requirements:

- The kind and variety of the seed or each seed constituting 5% percent or more in a mixture – ensure that seed mix labels bear the word “mixture” or words “mixed seed”.
- The country or state where the seed is grown
- The lot number or other lot identification
- The total percentage, by weight, of other crop seed
- The total percentage, by weight, of weed seed
- The total percentage, by weight, of inert matter
- Statement of “No Noxious (weed) Found”
- For each named seed:
 - a) Percentage of germination
 - b) Percentage of hard seed, if more than 1% (Hard seed is seed with a shell or coating that may delay germination)
- Month and year of (seed) test
- Name and address of seed labeler or seller
- If seed inoculant is used, the claimed date that inoculant effectiveness ends
- For treated seed (if any present):
 - a) Statement that the seeds have been treated
 - b) Name of any chemical used in the treatment
 - c) Descriptive statement of any process used in the treatment
 - d) Warning statement for any residual chemicals used
- Net weight of each container

The label must be correct and the purity, germination and other information on the tag must be backed by a dated seed lab analysis report. High quality seed germinates well, has a high purity percentage, and is free of noxious weeds or unintended species. The identity, purity and uniformity of the seed must be maintained at all times by continuing to monitor seed delivered to the project for proper labeling.

Seed suppliers may perform calculations using the germination and purity percentages of the seed to determine the Pure Live Seed (PLS) and blend the seed mixes with the PLS already determined. Seed container labels will provide this information if that step is already taken.

See Section 01030 for special labeling requirements for Certified Seed. Native seed may also have unique labeling requirements that will be shown in 01030.13 and the project Special Provisions.

All seed must be tested. Lots containing weed seeds as listed by State or Federal law are not allowed. If there is reason to be suspicious of the quality of the seed, it is advisable to have samples of the seed tested at the state seed laboratory. Wet, moldy, or otherwise damaged seed should

not be accepted. If a specified seed variety is not available, the contractor needs to consult with the Agency and receive approval of any proposed substitutions prior to any substitutions. Seed must be used with 18 months of testing. Seed should be used soon after purchase and should be stored for any length of time in a cool and dry space. Seed should not be subject to extreme heat or cold temperatures prior to application.

7.3.4 Pure Live Seed Calculation

This is a method of calculating an amount of seed to be planted which takes into account the variation of seed germination and purity of the seed source. Before calculating the Pure Live Seed (PLS) verify that the seed has not already gone through this exercise and been packaged as PLS.

$$\text{Pure Live Seed (PLS)} = \% \text{ Germination} \times \% \text{ Purity}$$

Example:

A recommended seed mixture requires that 26 lb (PLS) of intermediate wheatgrass be planted.

Intermediate wheatgrass germination = 80% (0.80)

Intermediate wheatgrass purity = 90% (0.90)

$$0.80 \times 0.90 = 0.72 \text{ or } 72\% \text{ PLS}$$

26 lb (PLS) to be planted = Approximately 37 lb. of bagged seed should be

0.72 (PLS factor) used so that 26 lb. of PLS will be planted.

7.3.5 Weed Free Straw/Straw Bales

Grass seed crops in Oregon become certified through the Oregon State University Extension Service. This program was created to ensure that the seed that is produced will be the correct species and variety and have genetic purity. The certification program includes an inspection of the field by OSU Extension where they look at whether the field has a buffer distance to prevent cross-pollination from other plant varieties, is noxious weed free, and meets other criteria related to seed purity. ODOT relies upon the OSU Extension seed certification program when specifying straw and grass seed for temporary erosion control in an effort to control the spread of noxious and other invasive weeds.

Straw from the certified fields in Oregon and straw bales are entitled to bind the bales with a unique purple and yellow twine. Straw bales are not approved BMPs sediment barriers or check dams, but loose straw is approved (and provides good protection) as temporary mulch for erosion prevention. (Straw bales are also used to form a basin structure to be lined with plastic sheeting for use as an approved concrete washout basin.) Documentation must be provided that demonstrates the straw is certified weed free. Straw will contain viable seeds from the parent crop. A common crop for weed free straw is perennial rye grass. Rye grass is not a native species

and although it is pervasive in many landscapes, it may be unwanted on projects where native permanent seeding is specified. Removal of temporary mulch may be required in Project Special Provisions.

Straw can originate from cereal grain as well, however, the grain crop must be from a certified field. Plants from grain crops may themselves be weeds. Cereal rye (*Secale cereale*) for example is a listed weed in Washington State (but not in Oregon). Designers must know the characteristics of the plants used in vegetative stabilization so as not to release unwanted plant pests into Oregon's environment. The OSU Extension Service keeps track of fields around the state that are certified. The OSU Extension Service has a presence in every county in Oregon and can be called if anyone needs assistance in finding a source for weed-free straw and certified grass seed.

7.4 Installation

Proper installation of erosion and sediment controls is absolutely essential. Performance of control measures is directly determined by how they are installed in the field, and often times the measures themselves can cause more damage when improperly installed than if they are not used at all. Installation of all base measures should be inspected and any deficiencies corrected prior to the start of land disturbing activities. Subsequent inspections of any additional installations should also be made throughout the life of the project as needed.

The inspector should be familiar with installation details for each BMP used on the project. Details for the correct installation of all specified BMP's are provided in the ESCP. Installation details for BMP's are also provided in [Chapter 3](#) of this manual, and in the Standard Drawings (Appendix C). Installation descriptions are provided in Section 00280 (Appendix B).

The application of mulch and seed is normally based on the rate described in the specifications. To assure the appropriate rate is applied, mark off an area of known dimensions and apply the specified amount of material over the area. This will provide a visual baseline for inspecting the rate of application over areas of similar area preparation and material specifications.

7.5 Measures During Construction

The approved ESCP should be viewed as an open-ended document, subject to approved adjustments and modifications. Contingencies such as changes in the construction schedule or unexpectedly severe weather frequently call for changes or adjustments to the plan.

In addition the contractor is required to monitor the performance of all erosion and sediment control practices and make minor adjustments as needed on a day-to-day basis. Major modifications, on the other hand, must be approved by the Agency before they are implemented.

The contractor's responsibility does not end with installation and maintenance of designated measures, the plan must also work effectively. Excessive erosion on the site or sediment leaving the project site is not acceptable. If performance of the ESCP is not adequate the plan must be revised and changes implemented to provide effective functioning as quickly as possible.

Directing work to improve erosion and sediment control is the role of the ESCM, however if ESCM is not providing effective erosion and sediment control the Project Engineer or even the regulatory agency (Oregon DEQ) can require changes. Major revisions may be made in the field if they are well documented and work effectively. The Project Manager or Engineer should discuss revisions that are ineffective with the engineer of record to bring expertise into the discussion and to improve future projects. All graded areas and the supporting erosion and sediment control measures should be monitored as required. All captured sediment from diversions and other water-treatment practices should be promptly removed. If washouts or breaks occur, they should be repaired immediately. Prompt maintenance of small eroded areas before they become significant permit violations is an essential part of an effective ESCP.

Inspections, changes, problems, and solutions should be documented on the Updated ESCP as described in Section 7.2.2. Weekly construction meetings should have erosion and sediment control as a standing agenda item. Meetings to review and update the ESCP before wet season work and before temporary work suspension should be conducted. Submittals for materials and alternative measures should be reviewed and approved.

7.5.1 Work Restrictions

All ODOT construction projects are required to restrict certain types of work, which may contribute to sediment-laden water leaving the project boundaries or entering waterways. The following work restricts may apply:

1. **Flag Clearing Limits:** Construction site clearing limits will be clearly flagged or otherwise delineated in accordance with the approved plans by the contractor. No ground disturbance is permitted beyond the flagged boundary. Flagging should be maintained for the duration of construction. Sensitive and restricted areas should be delineated with orange plastic mesh fence.
2. **Perimeter Controls Before Grubbing:** All appropriate perimeter controls should be installed prior to any major site grubbing operation. Perimeter controls usually consist of sediment barriers or sediment fences but also include interceptor ditches, berms in fill areas, along the banks of existing streams and toes of slopes. Redundant perimeter controls are recommended where risk is high or where debris from upslope might damage the controls.
3. **Wet Season Plan and Schedule:** Although the 1200-CA permit requires sites be prepared for rain events at all times, Oregon does have well defined seasons and risk of erosion and discharge of sediment increases in autumn. Prior to wet season work and before temporary work suspension for winter, the Agency should review the contractor's ESCP to verify that appropriate controls are implemented and maintained during the wet season work and suspended periods.
4. **Limit Disturbed Areas:** If soil erosion and sediment resulting from construction activities is not effectively controlled, the Agency will limit the amount of disturbed areas that can be effectively controlled.

5. **Install BMP's Early:** Erosion and sediment control features are required to be incorporated into the project prior to clearing, grading or other land altering activities. (See Section 00280.40). Furthermore, it is required that appropriate perimeter controls be installed before any ground disturbing activities (00280.41). All erosion and sediment control measures should be installed according to the approved implementation schedule, provide effective functioning and be in compliance with specifications and the 1200-CA permit.
6. **Stop Work:** Failure to control erosion and or pollution shall be cause for the Agency to stop all construction work until measures have been taken to bring all construction into compliance with these specifications. ODOT must self-regulate to ensure contractors comply with contract and permit requirements and to assure continuance with ODOT's trusted partner relationship with the regulatory agencies.

7.5.2 Stabilization Requirements

This is the definition of stabilization from the 1200-CA Permit:

Stabilization The completion of all soil disturbance activities at the site and the establishment of a permanent vegetative cover (not less than 70% cover), or equivalent permanent stabilization measures (such as riprap, gabions, geotextiles, or bioengineering methods) that will prevent erosion.

All soils that are exposed and disturbed by construction-related activities should be stabilized according to the following time frames:

- Statewide (Entire Year) – Stabilize within 7 days of exposure all areas within 100' of waterways, wetlands or other sensitive areas.
- Initiate stabilization whenever land disturbing activities have permanently ceased, or are temporarily inactive for 14 days.
- Complete the installation of stabilization measures no later than 7 days after stabilization has been initiated.

Satisfying the time frames for stabilization requires that measures that do not rely on seed germination may be needed.

7.5.3 Erosion Control Emergency Items

The contractor is required to have materials on hand as a contingency in the event of a failure or when required to shore up BMP's installed as part of the ESCP. A thorough Agency ESCP will have a list of required emergency materials provided in the 00280 Section of the Special Provisions. These items would be kept on-site and available for use in the event of heavy rainfall that creates runoff beyond the capabilities of the site's installed erosion control facilities. Materials that require mobilization or delivery are poorly suited for emergency use. Appropriate emergency materials would include replacements for products that are specified in the ESCP, such as inlet insert filter sacks. The quantity and type of emergency materials would vary

depending on the project type and size, but items that have multiple uses and can be quickly deployed are good choices. Examples of good BMPs for emergency materials to be kept on the project site for use in emergencies are:

- Straw wattles w/ stakes (Sediment barrier-type 3, check dams-type 2, inlet protection-type 7)
- 6 ml plastic sheeting
- Bags for sand bags (these are only empty bags, so they do not take up much space)
- straw bales for use as mulch
- biofilter bags w/ stakes (check dam-type 3, inlet protection-type 4, sediment barrier-type 2)

The emergency items may also be used at the discretion of the project inspector to strengthen the erosion control measures as needed during construction project. A discussion should take place between the inspector and the ESCM when making the decision when to employ these contingency erosion control items. An example would be when the contractor creates a stockpile of soil at the project site that was not anticipated during development of the ESCP. The plastic sheeting could be employed to cover the stockpile and the rope and sandbags would be used to secure the plastic from blowing around in the wind. Contingency materials on-hand which are not installed are paid for in the Lump Sum Bid Item under Section 00280 – Erosion Control. If the contingency erosion control items are not used during the project, the restocking costs are covered by the lump sum bid item “Erosion Control”.

7.6 Maintenance

Erosion and sediment controls must be maintained in good working order at all times in order to function as intended. These controls must be maintained and retained in place until the Agency issue notification of acceptance of permanent stabilization. All maintenance and repairs are included in the bid price submitted by the contractor and are contracted expenses.

Typical maintenance activities, guidelines, and failure modes for BMP’s are discussed in [Chapter 3](#) of this manual, and in Section 00280 (Appendix A). The inspector should be familiar with maintenance requirements for each BMP used on the project. It is noteworthy that maintenance activities and frequencies vary among the different BMP’s, and will depend largely on weather and other site conditions. In general, effective erosion prevention will diminish the need for maintenance on sediment controls.

7.6.1 Sediment Removal

Sediment shall be removed and the controls upgraded or repaired as needed or as soon as practicable, but no later than 2 days after the surrounding exposed ground has dried sufficiently to prevent further damage from equipment needed for repair operations. In the event of continuous rainfall over a 24-hour period, or other circumstances that preclude equipment operation in that area, additional sediment controls shall be hand-carried and installed in accordance with best management practices and as approved by the Agency. Catch basins insert

filter sacks shall be maintained when they reach 1/2 the capacity in sediment depth. Sediment shall be removed from sediment barriers (all types), check dams, and sediment traps once the sediment buildup has reached 1/3 the exposed height of the control or storage depth. Rock filters and filter berm material shall be replaced with new aggregate material when sediment substantially reduces the effective filtering capacity by 50 percent.

7.6.2 Construction Entrances and Paved Areas

Aggregate or other material specified shall be added, removed or “stirred” with bladed equipment to open pore space as needed to maintain proper function of the entrance areas. All paved areas shall be kept clean for the duration of the project. Sweeping and removal of material or using a vacuum sweeper is the correct method to remove sediment from pavement.

Water from wheel wash facilities shall be treated to remove suspended sediment prior to discharge.

7.6.3 Sediment Disposal

Removed sediment shall be regraded into slopes or removed and disposed of off-site in accordance with Section 00290.20, all federal, state and local laws and ordinances. Sediment-laden water shall not be flushed into the storm drain system or waterways of any type.

7.7 Finishing and Cleanup

Within 30 days of the notification of acceptance of permanent stabilization, temporary erosion and sediment control materials should be removed from the area. Areas disturbed by the removal process should be permanently stabilized. All materials associated with temporary erosion and sediment control that are not incorporated into the permanent work become the property of the contractor.

Removed sediment should be regraded into slopes or removed and disposed of off-site. Sediment-laden water can be settled, treated or reused on site. It should not be discharged directly to any water body, either treated or untreated.

7.8 Inspector’s Tools

The following sections provide additional resources for the inspector to verify that adequate erosion and sediment control planning and measures are implemented. These checklists and guidelines are also useful for the ESCM as they outline ODOT’s expectations for proper erosion and sediment control management.

7.8.1 Inspector Checklist

The Inspector Checklist included in Appendix E should be used by Agency representatives when inspecting erosion and sediment controls on a project site. The checklist is intended to

summarize the key elements of a successful erosion and sediment control program. Topics on the checklist include:

- Schedule Review
- Erosion and Sediment Control Plan
- Erosion and Pollution Control Manager
- Sensitive Areas
- Contingency Plans
- Materials On-Hand
- Maintenance
- Monitoring Forms
- Slope Protection and Stabilization
- Plan Revisions and Modifications
- BMP Evaluation
- Technical Resources
- Additional Items

7.8.2 Winterization

The wet season, as defined in the Standard Specifications, in Oregon is October 1 through May 31. The 1200-CA permit requires that erosion and sediment controls be in place and provide effective functioning at all times and all weather conditions regardless of time of year. Still, storm frequency and risk is increased during the defined wet season. Prior to wet season work and before temporary work suspension for winter, the contractor shall meet with the Agency to review and update the ESCP and to develop a schedule to assure that appropriate controls are implemented and maintained during wet season and work suspension periods. When sites are inactive, the contractor's ESCM remains responsible for periodic inspections every two weeks and within 24 hours of any rain event (or snow melt) that results in stormwater runoff leaving the project site.

Winter preparations should begin in August. Winterization planning should address the items listed above, and in the "Inspector Checklist" and "Buttoning Up Construction for the Rainy Season" list in Appendix E.

7.8.3 Rules of Thumb

Several Rules of Thumb worksheets are provided in Appendix D to aid designers and inspectors in determining and verifying the quality and quantity of various erosion control items. These are especially useful when verifying the application rates of various mulch and hydraulically applied products. Appendix D includes the following:

- Example Seed Tags
- Slope Inclination Conversions
- Slope computation factors

- Sediment Trap Sizing Spreadsheet – Sediment Trap plans must be stamped and signed by qualified professional.
- I-D-R Curve Zone Map
- Straw Mulch Application Worksheet
- Hydraulic Application Equations
- Wood Fiber Mulch Hydraulic Application Worksheet
- Seed / Fertilizer Hydraulic Application Worksheet
- Hydraulic Application Example Problems

Appendix

List of Tables

Table 2-1 Overview of Pollutant sources, impacts, and indicators.....	36
Table 3-1 Matrix of temporary and permanent erosion control measures and estimated effectiveness .	44
Table 3-2 Slope drain sizes.....	82
Table 3-3 Spacing for check dams.....	90
Table 3-4 Interceptor Dike/Interceptor Swale	92
Table 3-5 Interceptor swale design criteria	93
Table 3-6 Interceptor swale spacing design criteria.....	93
Table 3-7 Barrier spacing for general application.....	104
Table 3-8 Inlet protection selection based on site conditions.....	126
Table 6-1 USDA Particle size classes.....	146
Table 6-2 Outlet riser pipe diameters.....	156
Table 6-3 List of recommended outlet riser pipe diameters.....	157
Table 6-4 EROSION SEDIMENT CONTROL PLAN TABLE OF LOCATION	170

List of Figures

Figure 1-1 Fiber rolls shorten slope length and grass covers soil, preventing erosion	11
Figure 2-1 Good Sediment Control.....	25
Figure 2-2 Major Types of Soil Erosion	27
Figure 2-3 Splash	27
Figure 2-4 Rills on a Slope.....	28
Figure 2-5 Matting Product Provides Protection of Waterway from Erosion	32
Figure 2-6 Sediment Non-Compliance	33
Figure 2-7 Erosion control failure at water quality facility.....	35
Figure 2-8 No erosion, stable channel & clear water	37
Figure 2-9 Compost blankets provides erosion prevention	38
Figure 2-10 Seeded perennial rye grass with wattles to shorten slope length	38
Figure 2-11 Check Dams slow runoff velocity	39
Figure 2-12 Stabilized Channel	40
Figure 2-13 Sediment Trap & Energy Dissipater W/ Level Spreader	40
Figure 2-14 Rectilinear Grading	41
Figure 2-15 Contour grading with slope rounding.....	42
Figure 2-16 Stepped Slope.....	42
Figure 2-17 Geogrid	43
Figure 2-18 Horizontal Drains	43
Figure 3-1 Cereal Rye.....	51
Figure 3-2 Spoils Pile.....	52
Figure 3-3 Roughened Soil Surface	56
Figure 3-4 Seeding & mulch applied with Hydroseeder	57
Figure 3-5 Straw Mulch being blown on site	59

Figure 3-6 Good cover with straw mulch62

Figure 3-7 Thin hydromulch application65

Figure 3-8 Plan for seeding/mulching long slopes66

Figure 3-9 Installation of wetland sod67

Figure 3-10 fully biodegradable slope protection matting.....69

Figure 3-11 Plastic netting at 5 years.....70

Figure 3-12 Compost blankets provides erosion prevention.....75

Figure 3-13 Plastic sheeting runoff control on slope matting76

Figure 3-14 Temporary Slope Drains80

Figure 3-15 Plastic sheeting used as Temporary Slope Drains.....81

Figure 3-16 Energy Dissipater (permanent installation)84

Figure 3-17 Surface Roughening85

Figure 3-18 Check Dam88

Figure 3-19 Interceptor Dike/Interceptor Swale91

Figure 3-20 Construction Entrance98

Figure 3-21 Stabilized Haul Road102

Figure 3-22 Fiber Rolls (Wattles) – Sediment Barrier Type 3.....106

Figure 3-23 Compost Sock – Sediment Barrier Type 8109

Figure 3-24 Novel brush barrier (brush wattles) Installation in Germany113

Figure 3-25 Aggregate Barrier Type 6 Retains sediment in aggregate berm.....115

Figure 3-26 Pre-fabricated Barrier System – Sediment Barrier Type 7116

Figure 3-27 Sediment fence is trenched in correctly118

Figure 3-28 Sediment fence should be removed once vegetation is established.....119

Figure 3-29 Sediment fence maintenance failure.....121

Figure 3-30 Sediment fence not embedded in ground.....121

Figure 3-31 Inlet Protection – Geotextile Filter Fabric Insert (Type 3).....122

Figure 3-32 Inlet Protection – Biofilter Bags (Type 4)123

Figure 3-33 Inlet Protection – Curb Inlet Sediment Dam (Type 10).....123

Figure 3-34 Sediment Trap.....127

Figure 3-35 Passive Water Quality Treatment Swale130

Figure 3-36 Array of Baker Tanks131

Figure 4-1 Petroleum products are a common pollutant133

Figure 4-2 Concrete Washout - Standard Drawing RD01070134

Figure 6-1 Flow diagram of the stabilization requirements found in specifications159

Figure 6-2 EROSION CONTROL LEGEND169

Figure 6-3 Bid Item List.....173

ODOT provides a safe and reliable multimodal transportation system that connects people and helps Oregon's communities and economy thrive.

www.oregon.gov/ODOT



Benton County BMP Document

2022

APPENDIX H

Temporary Water Management
Oregon Department of Transportation (2014)

CHAPTER 18

TEMPORARY WATER MANAGEMENT

Table of Contents

18.1	Introduction.....	1
18.2	Policies and Practices.....	2
	18.2.1 Responsibilities.....	3
18.3	Definitions.....	3
18.4	Types and Selection of Isolation Options.....	4
	18.4.1 Common Isolation Option Elements.....	4
	18.4.2 Partial Isolation.....	5
	18.4.3 Full Isolation.....	9
	18.4.4 Working in the Wet.....	15
18.5	Temporary Water Management Components.....	18
	18.5.1 Isolation Barriers.....	19
	18.5.1.1 Sandbags.....	20
	18.5.1.2 Precast Concrete Barriers.....	24
	18.5.1.3 Water-filled Impervious Membrane.....	26
	18.5.1.4 Silt Curtains and Fences.....	29
	18.5.1.5 Sheet Piles.....	31
	18.5.2 Soil Stability Analysis.....	33
	18.5.3 Stream Flow Control.....	37
	18.5.3.1 Existing Channel.....	38
	18.5.3.2 Gravity Bypass Pipes.....	39
	18.5.3.3 Pumps.....	42
	18.5.4 Energy Dissipators.....	47
	18.5.4.1 Temporary Pad using Wood Sheeting.....	47
	18.5.4.2 Temporary Riprap or Gabion Pads.....	50
	18.5.4.3 Temporary Concrete Pads.....	54
	18.5.5 Sediment Control Facilities.....	56
	18.5.5.1 Filter Bags.....	56
	18.5.5.2 Rock Filter Berms.....	58
	18.5.5.3 Dispersion.....	61
	18.5.5.4 Sediment Trap.....	64
	18.5.5.5 Swales.....	66
18.6	Design Procedure.....	68
	DRY CREEK AT HWY 99W.....	72
	ESTIMATED DISCHARGES FOR.....	72
	TEMPORARY WATER MANAGEMENT.....	72
	In-Water work period extends from 1 July through 15 October.....	72

LIST OF FIGURES

Figure 18-1 Partial Isolation	8
Figure 18-2 Full Isolation — Piped Gravity Bypass	12
Figure 18-3 Full Isolation — Pump Bypass.....	13
Figure 18-4 Full Isolation — Combined Pump/Gravity Bypass.....	14
Figure 18-5 Working in the Wet.....	17
Figure 18-6 Sandbag Barriers.....	23
Figure 18-7 Precast Concrete Barriers	26
Figure 18-8 Water-filled Impervious Barriers	28
Figure 18-9 Silt Curtain and Fence Barriers.....	31
Figure 18-10 Sheet Pile Barriers.....	33
Figure 18-11 Wood Sheet Energy Dissipator	49
Figure 18-12 Temporary Riprap Energy Dissipator (channel bank application)	51
Figure 18-13 Temporary Riprap Energy Dissipator (channel application)	52
Figure 18-14 Temporary Gabion Energy Dissipator.....	53
Figure 18-15 Concrete Pad Energy Dissipator.....	55
Figure 18-16 Filter Bag.....	57
Figure 18-17 Rock Berm (channel bank installation).....	59
Figure 18-18 Rock Berm (channel installation)	60
Figure 18-19 Dispersion using Filter Strip with rock berm flow spreader	62
Figure 18-20 Dispersion using Filter Strip with perforated pipe flow spreader.....	63
Figure 18-21 Sediment Trap	65
Figure 18-22 Swale.....	67
Figure 18-23 Example Temporary Construction Limits and Extent of Work Area Isolation	77
Figure 18-24 Example Drawing of a TWM Concept Plan (Full Isolation).....	80
Figure 18-25 Example Drawing of a TWM Concept Plan (Full Isolation Page 2)	81
Figure 18-26 Example Drawing of a TWM Concept Plan (Partial Isolation).....	82

LIST OF TABLES

Table 18.5-1 TWM Components Selection Table	19
--	-----------

18.1 Introduction

This chapter provides information for the planning, design, and construction of temporary water management (TWM). This effort is expected to standardize designs and approaches, create workable and understandable designs, provide guidance for local agencies and contractors, and compliance with environmental regulations. Also, the quality of project TWM plans and specifications will improve by looking at TWM in detail during project design.



Photo examples of Temporary Water Management facilities

Temporary water management is the flow and sediment control of surface water and groundwater seepage during construction activities to be performed within bodies of water such as streams, creeks, rivers, wetlands, estuaries, or lakes. Temporary water management also provides a safe working area for construction within a waterbody utilizing a variety of barrier isolation options, materials, and equipment while meeting regulatory requirements related to water quality and fish passage when necessary. These flow and sediment control measures are temporary, usually utilized during the in-water work period, and installed/removed with coordination between the contractor and engineer.

Note that TWM can be utilized along most water bodies such as streams, creeks, rivers, wetlands, estuaries and lakes. ODOT implements many TWM plans along channel settings such as streams, creeks, and rivers, therefore, the guidance within this chapter will focus on channel work applications.

Typical construction activities that require temporary water management during installation or repair work include but are not limited to:

- bridge demolition or construction
- culvert removal or replacement
- embankment construction for roadway alignments

- stream channel modification
- habitat restoration
- streambank repairs

Compliance with the guidelines, criteria and the recommendations within this chapter does not guarantee that the proposed concept design will pass review by all permitting agencies. The guidance in this chapter, however, may reduce the number of regulatory review comments and the time needed for regulatory review and approval. Planning and designing for the temporary water management “Concept Plan” needs to be done early in project development.

The considerations for selecting and recommending an isolation option include worker safety during construction, water quality, aquatic life protection, fish passage, flow conditions, and constructability. Depending on the specific situation, temporary water management includes, but is not limited to, these activities:

- routing streamflow around or through the work area
- isolating the work area from streamflow or surrounding water
- removing water within and entering the work isolation area
- reducing sediment levels from water pumped from work area prior to releasing this water back into the main water body
- preventing fish and other aquatic creatures from entering the worksite during construction
- providing fish passage during or after working hours

Three isolation options of managing water during construction can be implemented:

- partial isolation
- full isolation
- working in the wet

Additional detail on these isolation options is presented in the remaining sections of this chapter.

18.2 Policies and Practices

General policies of the Federal Highway Administration (FHWA) and ODOT pertaining to hydraulic design are discussed in Chapter 3.

Agency practice specific to temporary water management design include:

- coordination with other federal, state, and local agencies concerned with water resources,
- safety of the general public, construction workers, and inspection staff.

18.2.1 Responsibilities

Many individuals within the ODOT Regions or individuals outside of the agency are involved with temporary water management. The responsibility of these individuals are as follows:

- The hydraulic designer coordinates the TWM concept development with the appropriate design team members through the design and permitting process, and prepares the:
 - TWM concept plan(s),
 - project hydraulics report with TWM recommendations, and
 - project specifications
- Environmental personnel apply for project permits. Getting the TWM information to the environmental personnel in a timely manner, allows for discussions with the regulatory agencies.
- The project manager assures the TWM is implemented and administers those aspects of the project construction.
- The contractor implements the TWM. The TWM concept plan and specifications allows for revisions based on site conditions. A stamped working drawing(s) is developed by the Contractor based on either the Agency's concept plan or and independent plan.

18.3 Definitions

Definitions of important terms are provided in this section. These and other terms defined in the manual glossary will be used throughout the remainder of this chapter in dealing with different aspects of temporary water management.

Isolation Barrier - A temporary barrier used to isolate the work area and turbidity from the actively flowing stream. Barriers can be created using sandbags, pre-cast concrete barriers, water-filled impervious barriers, and sheet piling; also known as a cofferdam.

Diversion - An activity that removes surface water or groundwater from the basin of origin to another watershed where this water would not normally flow.

In-water work period - A list of time periods created by the Oregon Department of Fish and Wildlife (ODFW) for construction activities within Oregon water bodies. These time periods are based on the times in which anadromous and/or game fish are least likely to be present.

<http://www.dfw.state.or.us/lands/inwater/>

Ordinary high water (OHW) – Generally defined as the mark on the bank or shore to which the high water ordinarily rises in any given season, excluding exceptionally high water levels caused by large flood events.

Rerouting - A pipe or constructed channel that conveys streamflow around the construction area, outside of the existing streambed and discharging the flow back to the same water body; also known as *bypass*.

Suspended solids - Particles floating in the water column. These may be organic or inorganic particles that can be trapped on a laboratory glass-fiber filter.

Turbidity - The refraction of light due to suspended solids in the water column. Turbidity is measured by a turbidimeter in nephelometric turbidity units (NTU) and by visual inspection.

Water body - A generic term to describe waters such as streams, creeks, rivers, lakes, estuaries, and wetlands.

18.4 Types and Selection of Isolation Options

The following section provides an overview of a few waterbody work isolation practices for highway-related construction activities.

18.4.1 Common Isolation Option Elements

Each temporary water management option has common elements as listed below:

- **Removing fish from the work area:** Nets are placed outside of the construction limits to exclude fish from the isolation work area and trap fish for removal. After nets are installed, the work area is surveyed for fish; detected fish are recovered and released back into the main water body outside of the work area. The fish removal process is mandatory and can only be done by ODFW approved biologists.
- **Installing a barrier to isolate the work area:** A barrier is needed between the work area and active channel or surrounding water body. The application goal is for the barrier to keep water out of the work area and to withstand pressures and forces exerted by the surrounding water. Sandbags, precast concrete barriers, and water filled impervious membranes are several common products that could be used to form an isolation barrier.
- **Dewatering the work area:** The work area is dewatered after fish are removed from the work area and the barrier is placed and secured as recommended by the project TWM plan. Water left remaining inside of the work area is removed by pumping it toward and into a temporary sediment control facility for treatment before it is released downstream of the project site. Dewatering can also occur throughout the construction phase to remove groundwater or water that may be seeping under or through the isolation barrier(s).
- **Sediment control:** The placement of barriers and other related construction activities tends to stir up sediment throughout the work area. Releasing turbid water into the adjacent water body could violate water quality regulations. Note that this is the primary reason sediment control measures are used during temporary water management. The most common BMPs

to remove sediment during partial isolation of water bodies include filter bags, dispersion areas such as filter strips, sediment traps, and swales. Use of any one of these sediment control measures removes low-to-medium levels of sediment. A combination of these measures should be used if high levels of sediment are encountered during the dewatering and construction process. The temporary sediment control facility is removed after work has been completed and the disturbed area(s) restored as recommended by the project restoration plan.

- **Rewatering the work area:** All isolation plan features need to be removed after work is completed and accepted by ODOT. The goal at this stage is to allow water to reclaim the work area by removing the isolation features. The ideal approach is to rewater the disturbed area slowly to minimize erosion and turbidity. This is to be done in such a manner as to not strand fish and to regain the pre-construction flow conditions.

There are three isolation options outlined below. The site constraints for these isolation options may include right-of-way limits, water rights issues, and environmental concerns just to name a few.

18.4.2 Partial Isolation



Photo example of Partial Isolation

Partial isolation is typically implemented when work will occur along or near the bank of a stream, river, lake, or estuary. The example provided utilizes a barrier that is placed next to and along the bank of a stream to establish a work area. Partial isolation allows for varying flow conditions to continue downstream through the non-isolated channel, maintains upstream and downstream fish passage, and minimizes affects to an aquatic ecosystem by dewatering small portions of the waterbody.

Partial isolation is intended to isolate an area to allow work in dry conditions and is typically implemented during projected low-flow conditions. The process and main features of this approach are:

- Removing fish from the work area to be isolated¹
- Installation of the isolation barrier¹
- Dewatering the isolated work area¹
- Sediment control throughout the construction process¹
- Removal of the isolation barrier and re-watering the work area¹

The partial isolation option is the combination of these features. Each of these features has specific limitations and requirements that need to be considered when developing a partial isolation plan. Additional information to guide the concept plan design is detailed throughout the remaining sections of the chapter. Figure 1 shows a general configuration of a work area using the partial isolation option.

Partial isolation could be considered and applied when:

- work will be performed within creeks, rivers or lakes
- work will be performed during the in-water work period
- upstream and downstream fish passage is required during work activities
- water is present and the work requires dry conditions
- there is no water present but highly probable
- staging is feasible or necessary during repair or construction activities

Activities that could require partial isolation include but are not limited to:

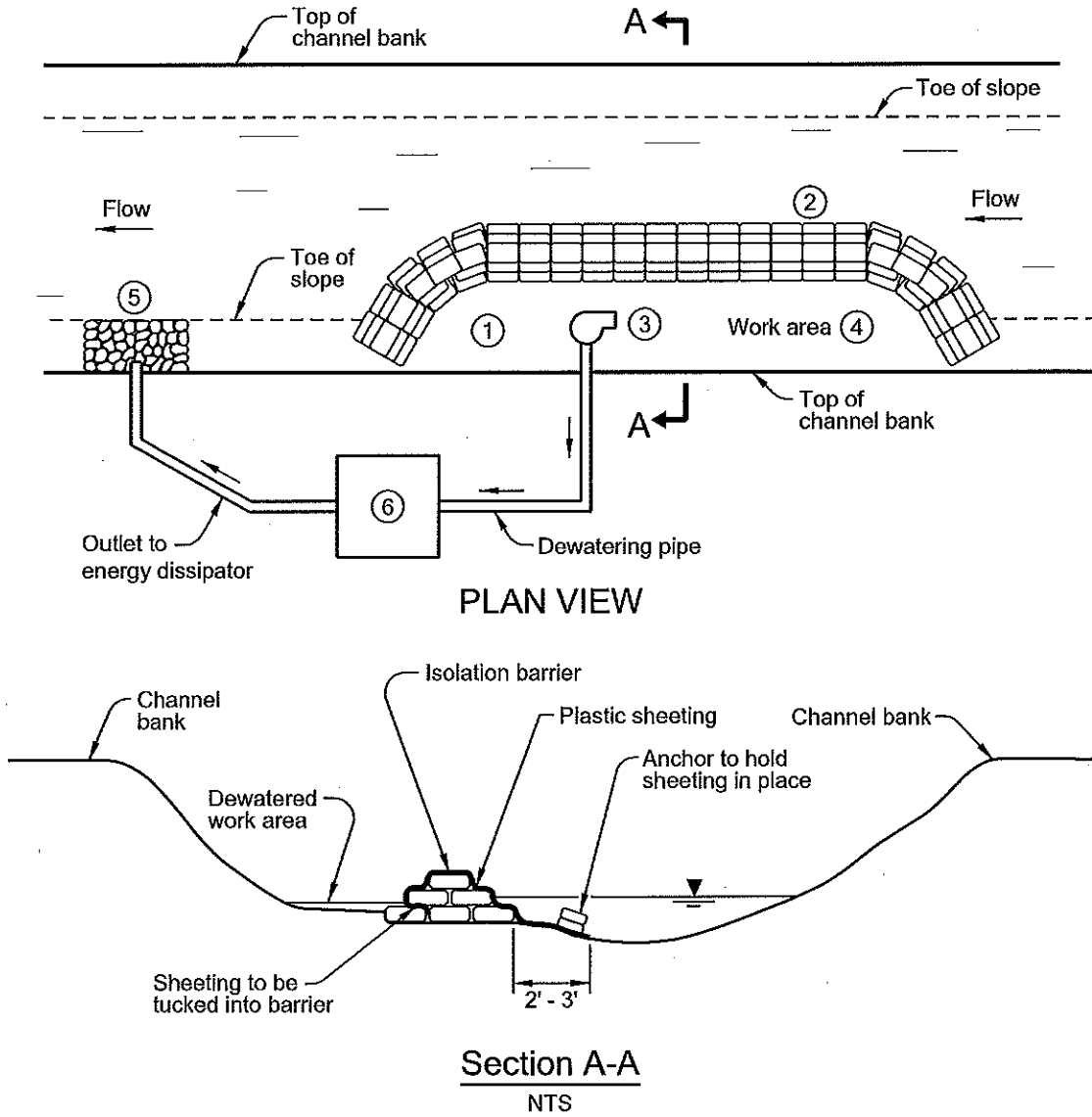
- bridge abutment maintenance and construction
- pier maintenance and construction (e.g., spread footings, bents)
- embankment protection

¹ Refer to Section 18.4.1 Common Isolation Option Elements for full descriptions of the elements that are common between the three listed isolation options.

- streambank restoration
- streambed repair or restoration
- bridge demolition
- installation of temporary work platforms

Partial Isolation limitations:

- Typically applied during low flow conditions within creeks or rivers. When temporary water management is needed beyond low flow conditions appropriate engineering would be needed to withstand the greater forces, pressures and flows.
 - Typically applied along one side or the other of creeks or rivers. May need to consider full isolation when work is necessary within or across a stream channel.
-



LEGEND

1. Fish recovery is required.
2. Isolation barrier. See section 18.5.1
3. Dewatering pump with fish screening. See section 18.5.3.
4. Dewatered work area
5. Energy dissipator. See section 18.5.4
6. Temporary sediment control facility. See section 18.5.5

Pump

Figure 18-1 Partial Isolation

18.4.3 Full Isolation



Photo example of Full Isolation

Full isolation is typically implemented when work will occur from bank to bank of a stream. The example provided uses barriers that are placed upstream and downstream of the work area and span the width of the active channel. The barriers keep streamflow out of the work area while a temporary bypass system is used to reroute streamflow through or around the work area.

Full isolation is intended to isolate an area to work in dry conditions and is typically implemented during projected low-flow conditions. The process and main features of this approach are:

- Removing fish from the work area to be isolated:²
- **Installation of the isolation barrier:**² A barrier is needed between the work area and active stream channel upstream to block the natural flow and downstream of the work area to block backwater conditions. The application goal is for the barrier to keep water out of the work area and to withstand pressures and forces exerted by the retained streamflow.
- **Routing streamflow through a pipe, pump, or combination of these features:** A stream flow conveyance feature or features needs to be installed and available for the duration of construction to convey flows around or through the work area and release flow back into the waterway. The two most common conveyance options are gravity (e.g., a temporary pipe) or pump bypass. The installation of the conveyance features and barrier should be coordinated at the same time.

² Refer to Section 18.4.1 Common Isolation Option Elements for full descriptions of the elements that are common between the three listed isolation options.

- **Dewatering the isolated work area:**² Note that the purpose of the gravity bypass pipe is used for streamflow rerouting and not for dewatering. Water pumped from the work area must be transported to a temporary sediment control facility for treatment before it is returned to the stream channel.
- Sediment control:²
- Removal of the isolation barrier and re-watering the work area:²

Each of these features has specific limitations and requirements that need to be considered when developing a full isolation plan. Additional information to guide the concept design of each of these features is detailed throughout the remaining sections of the chapter. Figures 2 through 4 illustrate general configurations of a work area implementing the full isolation option along a stream channel.

Full isolation should be considered and applied when:

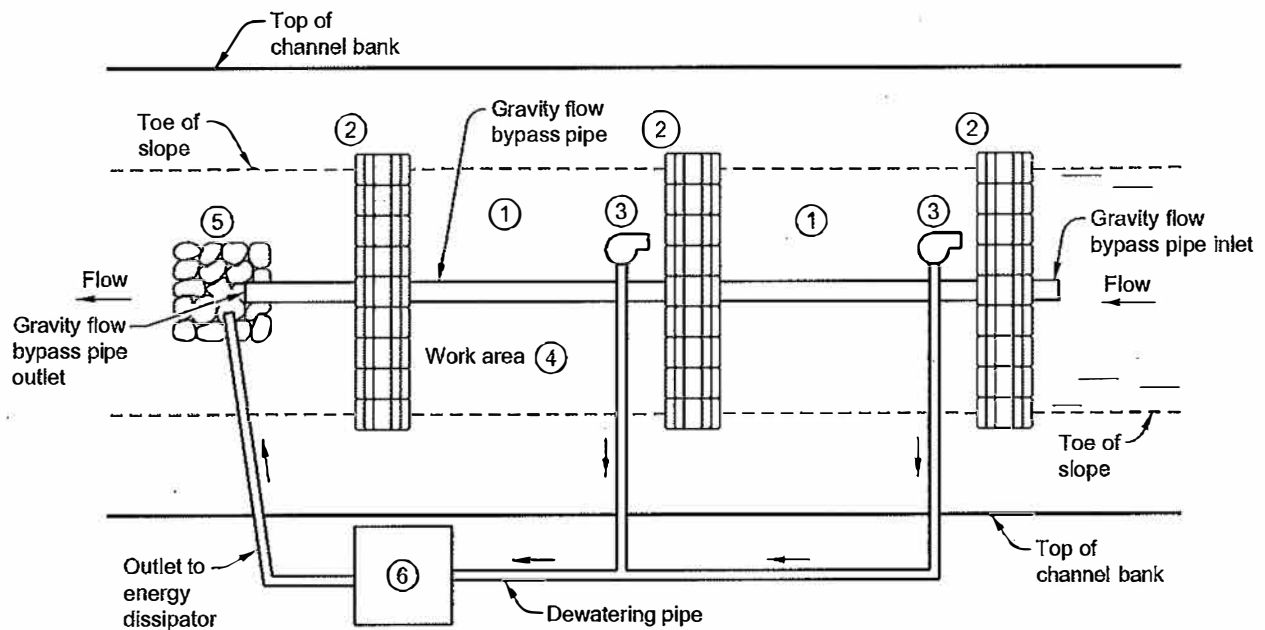
- work will be performed within creeks, rivers or lakes,
- work will be performed during the in-water work period,
- upstream and downstream fish passage is not required,
- water is present and work requires dry conditions, and
- channel bottom and/or bank to bank access is needed to perform work

Activities that could require full isolation include but are not limited to:

- bridge abutment maintenance and construction
- pier maintenance and construction (e.g., spread footings, bents)
- embankment protection
- streambed repair or restoration
- streambank restoration
- bridge demolition
- installation of temporary work platforms

Full Isolation limitations:

- Typically applied during low flow conditions within creeks or rivers. When temporary water management is needed beyond low flow conditions appropriate engineering would be needed to withstand the greater forces, pressures and flows.
- Fish passage (downstream and/or upstream) in a gravity system may not be possible due to depth/velocity requirements. Designers may want to consider partial isolation when fish passage is necessary.
- Fish passage is not possible when pumps are used for re-routing stream flows.



PLAN VIEW

NTS

LEGEND

1. Fish recovery is required.
2. Isolation barrier. See section 18.5.1
3. Dewatering pump with fish screening. See section 18.5.3
4. Dewatered work area
5. Energy dissipator. See section 18.5.4
6. Temporary sediment control facility. See section 18.5.5


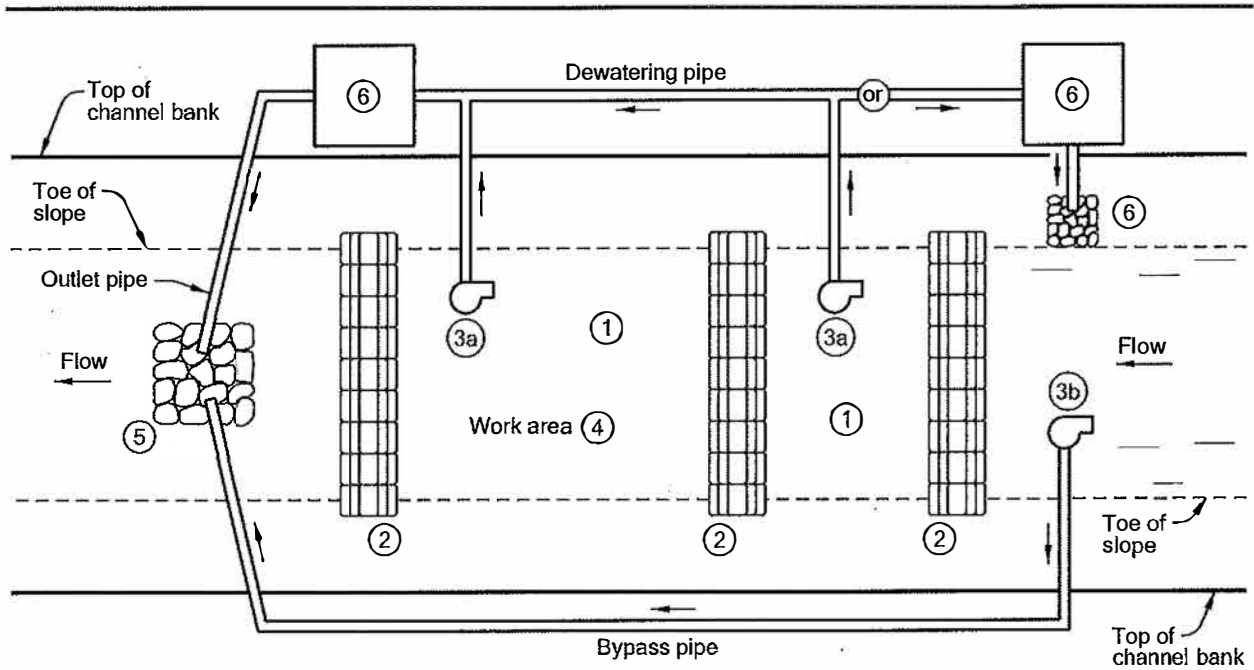
 Pump

Figure 18-2 Full Isolation — Piped Gravity Bypass



PLAN VIEW
NTS

LEGEND

1. Fish recovery is required.
2. Isolation barrier. See section 18.5.1
3. Dewatering pump with fish screening.
See section 18.5.3
4. Dewatered work area
5. Energy dissipator. See section 18.5.4
6. Temporary sediment control facility. See section 18.5.5


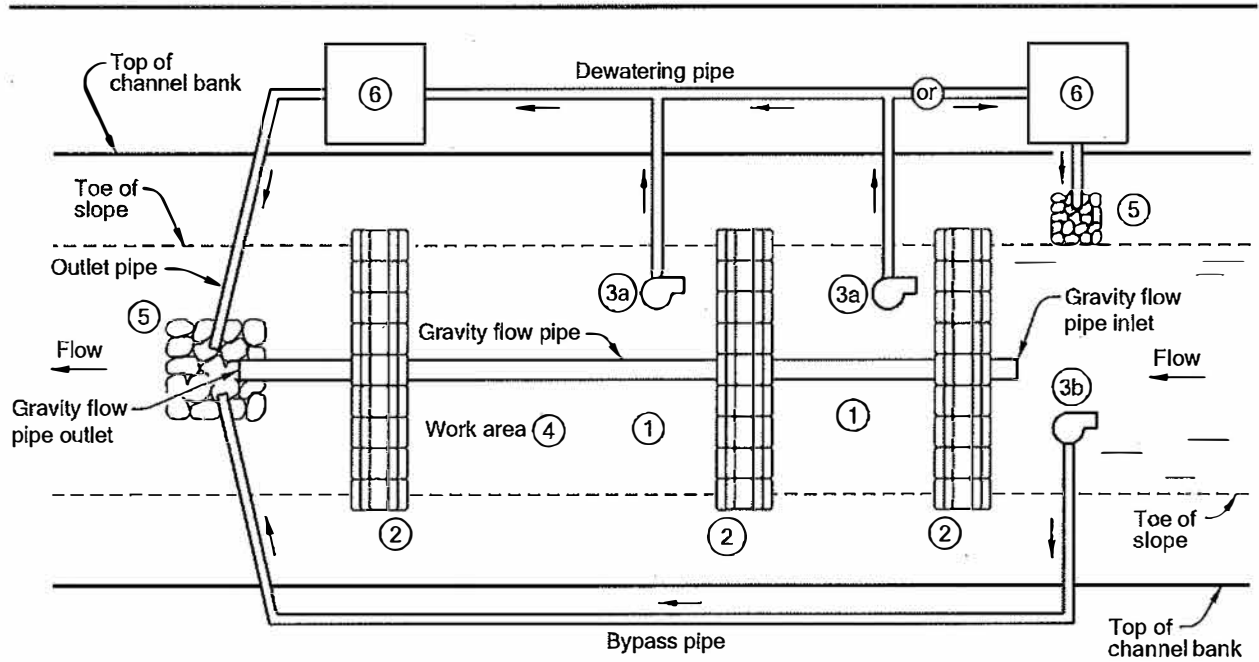
 Pump

Figure 18-3 Full Isolation — Pump Bypass



PLAN VIEW

NTS

LEGEND

- 1. Fish recovery is required.
- 2. Isolation barrier. See section 18.5.1
- 3a. Dewatering pump with fish screening. See section 18.5.3
- 3b. Bypass pump with fish screening. See section 18.5.3
- 4. Dewatered work area
- 5. Energy dissipator. See section 18.5.4
- 6. Temporary sediment control facility. See section 18.5.5



Pump

Figure 18-4 Full Isolation — Combined Pump/Gravity Bypass

18.4.4 Working in the Wet



Photo example of Working in the Wet

Working in the wet allows for the completion of certain construction activities while water is present in the work area. It uses a barrier that is placed between the work area and the remaining portion of the active channel.

Working in the wet option is used when equipment does not need to enter the channel and sediment can be managed within the identified work area. The benefits of working in the wet include lower costs and decreased disturbances to aquatic resources.

The process and main features of this approach are:

- **Removing fish from the work area:**³ Nets are placed outside of the intended work area to exclude fish from the isolation work area and trap fish for removal. After nets are installed, the work area is surveyed for fish, and detected fish are recovered and released back into the main water body. The fish removal process is mandatory.
- **Installing a barrier to isolate work area:**³ A barrier is needed between the work area and active channel or surrounding water body. The application goal is for the barrier to contain turbid water and prevent it from spreading into the waterway. Silt fences and silt curtains are a few common products that could be used to form a working in the wet isolation barrier.

³ Refer to Section 18.4.1 Common Isolation Option Elements for full descriptions of the elements that are common between the three listed isolation options.

- **Sediment Control:**³ The most common approach to deal with sediment during wet isolation is to allow sufficient time for sediment to settle before removing the barrier. The barrier should remain in place until significant settlement has occurred throughout the isolated area.
- **Activate the work area:** The isolation barrier needs to be removed after all work is completed. Barrier removal should be done slowly to prevent re-suspension of sediment and reduce turbidity.

Each of these features has specific limitations and requirements that need to be considered when developing a working in the wet plan. Additional information to guide the design of each of these features is detailed throughout the remaining sections of the chapter. Figure 5 is a general configuration of working in the wet isolation area.

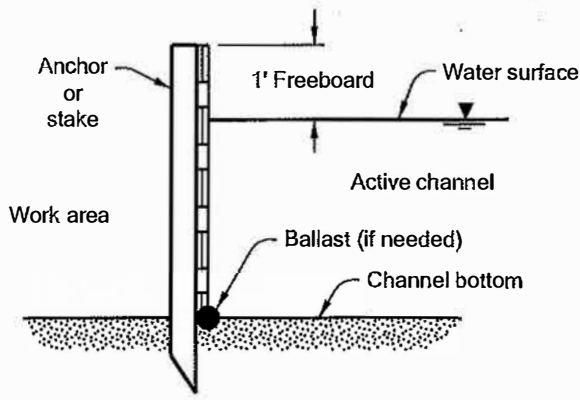
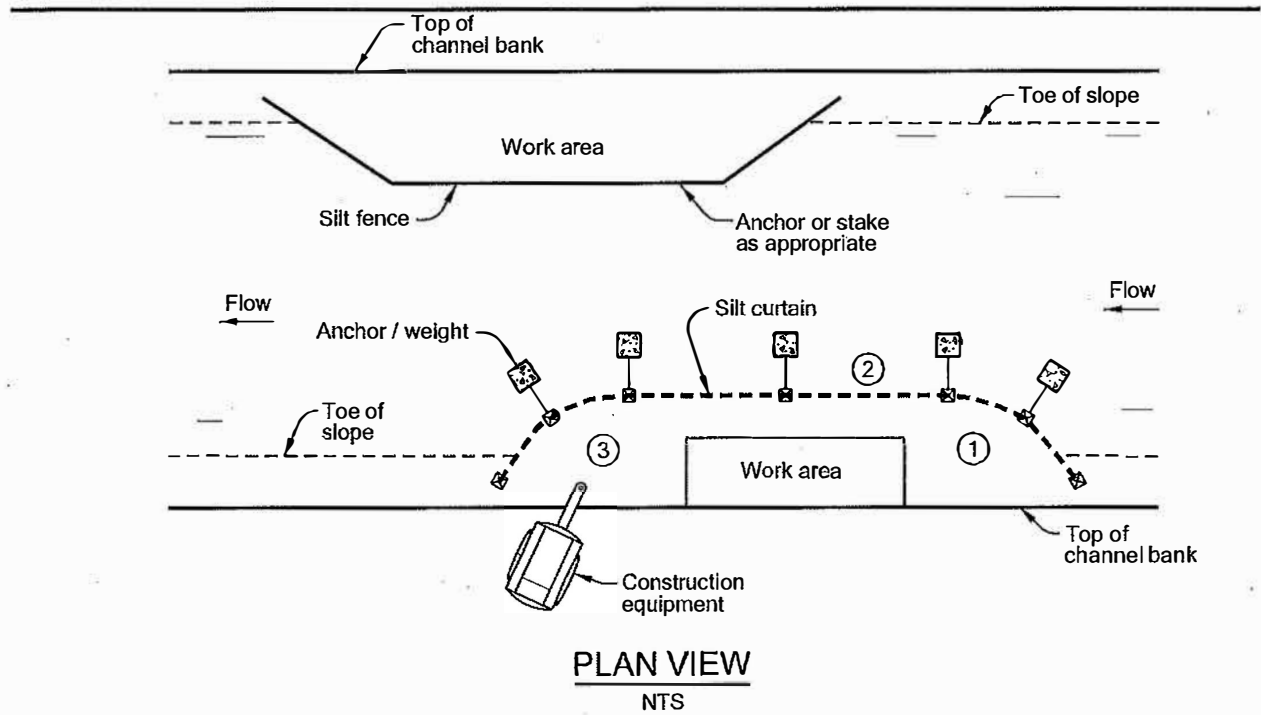
Working in the wet should be considered and applied when:

- work will be performed during a short time frame
- low to moderate water depth is anticipated
- water is present and work does not require dry conditions
- construction equipment does not need to be placed within the channel
- Impacts to fish and habitat would be greater by installing isolation
- streambanks that are not susceptible to erosion or failure and would allow equipment to work along the top of bank

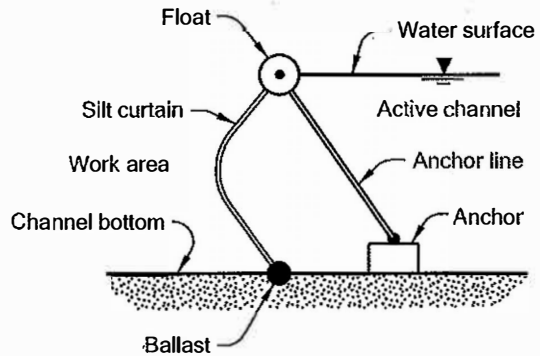
Activities that could require working in the wet include but are not limited to:

- streambed restoration
- streambank stabilization or restoration
- placement of canisters (drilled shafts)
- pile driving

³ Refer to Section 18.4.1 Common Isolation Option Elements for full descriptions of the elements that are common between the three listed isolation options.



Silt Fence
NTS



Silt Curtain
NTS

LEGEND

1. Fish recovery is required.
2. Isolation sediment barrier. See section 18.5.1.4 for design guidance.

Figure 18-5 Working in the Wet

Working in the wet limitations:

- Sediment control may not be possible without violation of water quality standards, such as elevated turbidity. May want to consider partial isolation when turbidity conditions cannot be maintained below the standard.
- Equipment cannot be placed in the stream channel or waterway.
- Typically applied during low flow and low velocity conditions within creeks, rivers, and lakes.

18.5 Temporary Water Management Components

Temporary Water Management (TWM) components are discussed in this section. TWM components are used to establish an isolation barrier between the active channel/waterway and work area, convey stream flows through or around the work area, and control erosion and sediment produced from construction activities.

Partial Isolation consists of the following components:

- Isolation barrier
- Dewatering pump
- Energy dissipator
- Sediment control feature

Full Isolation consists of the following components:

- Isolation barriers
- Bypass pipes and/or pumps
- Dewatering pump
- Energy dissipator
- Sediment control feature

Working-in-the-Wet consists of the following components:

- Isolation/Sediment barrier

Table 18.5-1 provides a selection process for TWM components based on the various site conditions that may be present.

Table 18.5-1 TWM Components Selection Table

Temporary Water Management – Component Type Matrix		Temporary Water Management Site Conditions																
		Flow Conditions		Soil Type and Conditions				Surface Slope/Grade				Depth of Flows				Site Accessibility		
		Low flow s < 0.5 cfs	Moderate flow s < 6.0 cfs	Soft silts, muds or loose sands *	Stiff clays or Dense sands and gravels	Large gravels or cobbles	Cobbles or boulders	Flat or slopes <3%	3% to 8%	8% to 15%	Slopes > 15%	0 to 2 feet	2 to 4 feet	4 to 6 feet	6 to < 20 feet	No access for equipment	Limited access for equipment	Easy access for equipment
TWM Component Type	Sandbags	■	■	○	■	■	■	■	■	○	■	■	-	-	■	■	■	
Precast Concrete Barriers	■	■	-	■	○	○	■	○	-	-	■	■	○	-	-	○	■	
Water Filled Membrane	■	-	○	○	○	-	■	○	-	-	■	■	○	-	○	○	■	
Silt Curtain and Fences	■	-	■	○	-	-	■	○	○	○	■	■	○	○	■	■	■	
Proprietary Structures	***	***	***	***	***	***	***	***	***	***	***	***	***	***	***	***	***	

- = Component is recommended for use under site condition
- = Component may have limitations under site condition
- = Component not recommended for use under site condition
- * = soft or loose soils are defined as easily penetrated (>12") by 1/2" rebar pushed by hand. Consult with project Geotechnical Engineer if soft soils are encountered.
- *** =Proprietary components shall be designed and installed as recommended by the manufacturer

18.5.1 Isolation Barriers

An isolation barrier is needed and used when construction work is to be performed within a waterbody. The primary use of isolation barriers is to:

- isolate the worksite from the adjacent waterbody
- keep water out of the isolated area
- mark isolation limits
- contain sediment laden water
- keep fish out of the isolated area

There are several products available for barrier isolation. A few of the barrier types that will be briefly discussed in the following sub-sections include:

- Sandbags
- Precast concrete barriers
- Water-filled impervious membranes
- Silt curtains and fences

Refer to the various manufacturers for more detailed information on the products discussed to assist with proposing the most appropriate barrier(s) for a given application and anticipated site constraints.

18.5.1.1 Sandbags

A barrier constructed of sandbags has been historically used as a means of holding back floodwaters and successfully used to prevent overtopping of levees. This type of barrier relies on its self-weight to resist overturning and sliding.

Sandbags are rectangular, durable, weather resistant, tightly woven bags sufficient to prevent leakage of filler material. They are commonly filled with dry sand or fine gravel.

A sandbag barrier is constructed by stacking them atop one another, in an alternating brick-like fashion, and topped with a plastic sheeting to form a water tight seal. See Figure 6.

Advantages:

- Can accommodate long lengths of barrier protection
- Simple to design
- Easy to construct
- Materials are inexpensive and readily available
- Can be installed at various heights
- Flexible enough to accommodate terrain slope changes
- Reusable
- Damage can be repaired during use
- Can be utilized with other barrier types to add additional resistance to movement or used to help form a water tight seal

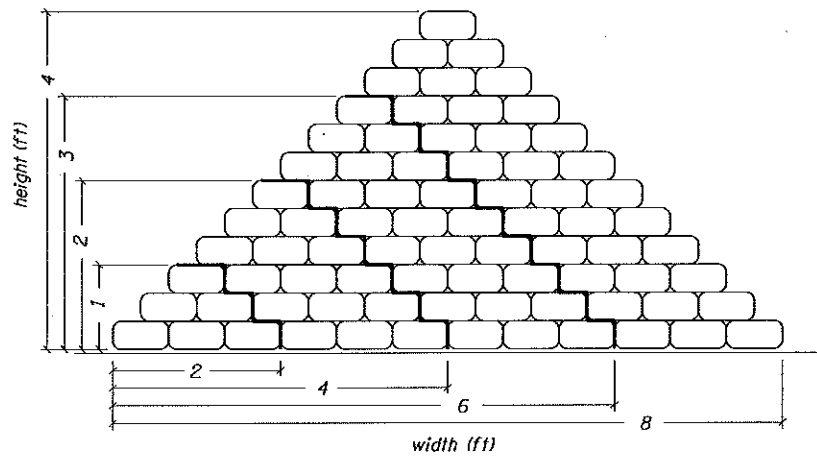
Disadvantages:

- Manual labor needed to install and remove
- Footprint increases with barrier height
- May not seal completely if placed on larger gravels and cobbles

Implement into the concept plan utilizing a few common guidelines:

- A height to width ratio of 1:2 (e.g., a 1 foot high wall would have a base width of 2 feet). This is the minimum width-to-height ratio that should be used to construct a sandbag barrier. See footprint detail below.
- Sand bag weight can vary. The sandbag dimension noted below is for a 30 pound bag of dry sand. These are the ideal size and weight of a bag because they are easier to transport around the job site and easier to mold and form into place.
- A plastic sheeting cover will improve water tightness. Do not utilize plastic sheeting underneath the bags since that will increase the potential for the barrier to slide.
- Likely stability failures: sliding, excessive seepage under barrier, and collapse.
- Sand bag dimensions can vary. The estimated number of bags needed for a 1:2 ratio is noted in the following table. This is based on each bag having placed dimensions of about 4 to 5 inches high by 9 to 10 inches wide by 14 inches long.

Height of sand bag barrier (feet)	Approximate number of bags used per 100 lineal feet of barrier
1	600
2	1700
3	3000
4	5500



Sandbag footprint detail

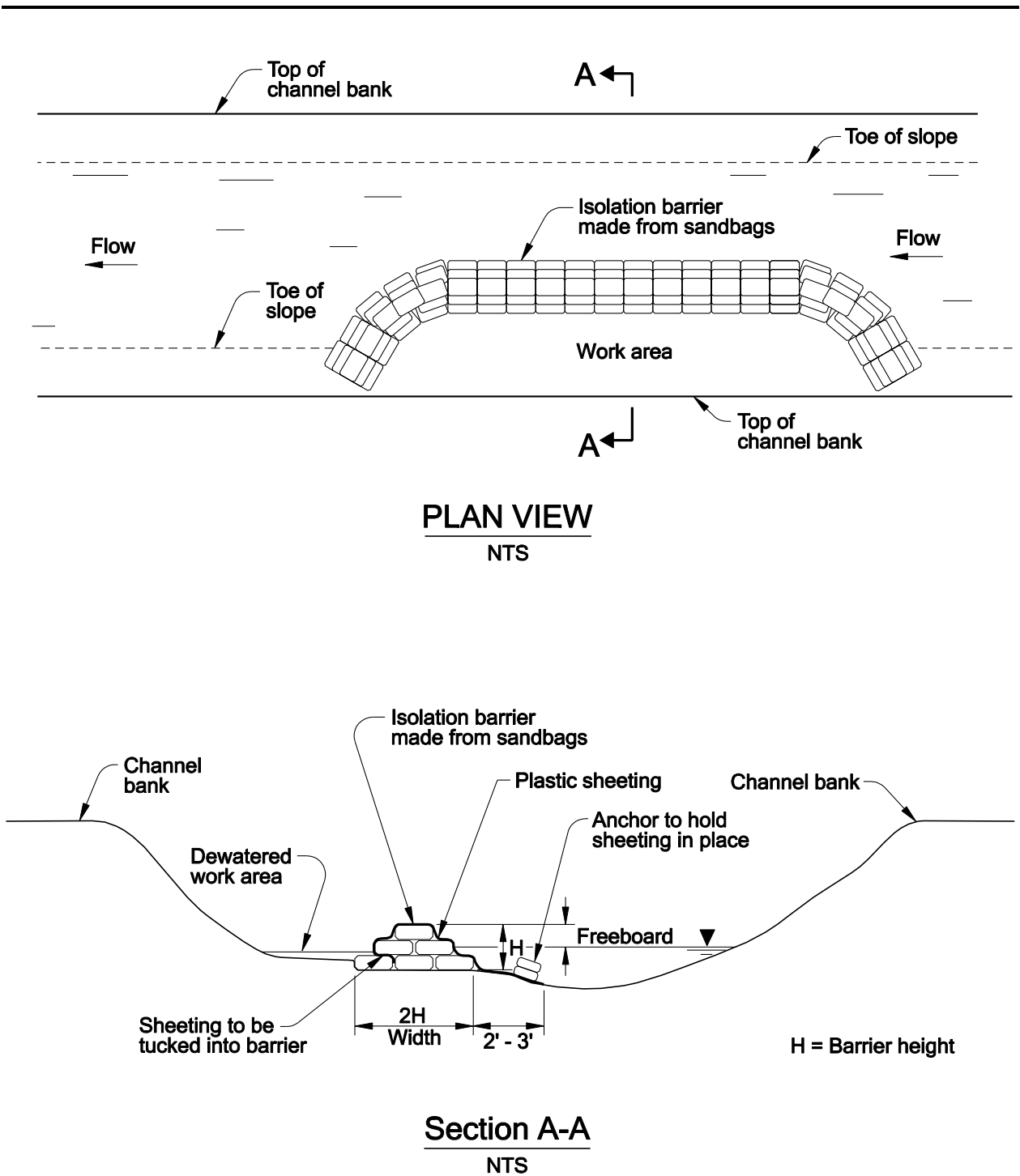




Photo example of Concrete Barriers with Sandbags

18.5.1.2 Precast Concrete Barriers

A work isolation barrier could be created using pre-cast concrete traffic barriers or eco-blocks. These barriers are gravity structures depending on their weight for stability. Common TWM application is to position concrete barriers end-to-end and topped with plastic sheeting to form a water tight seal. See Figure 7.

Advantages:

- High resistance to lateral forces and pressures from high water velocities
- Form an immediate wall because of their inherent height
- Durable
- Reusable
- Barrier height can be increased by stacking

Disadvantages:

- Requires construction equipment capable of heavy lifting
- Need a lot of storage area during construction staging
- High seepage under barrier is likely
- High bearing pressures on soil

Implement into the concept plan utilizing a few common guidelines:

- Standard concrete traffic barriers are available in heights of 32 or 42-inches:
 - 32-inch high barrier:
 - single section is 12.5 ft. long and 2 ft. wide at the base
 - weighs 5,710 lbs.
 - See Standard Drawing [RD500](#)
 - 42-inch high barrier:
 - single section is 12.5 ft. long and 2'-2" wide at the base
 - weighs 7,970 lbs.
 - See Standard Drawing [RD545](#)
- Recommended use along mild slope channels
- Adequate site accessibility is needed for heavy equipment to install and remove concrete barrier
- A plastic sheeting cover will help form a water tight seal
- Likely stability failures: sliding, excessive seepage, bearing capacity, and possible overturning



Photo example of Partial Isolation with Concrete Barriers

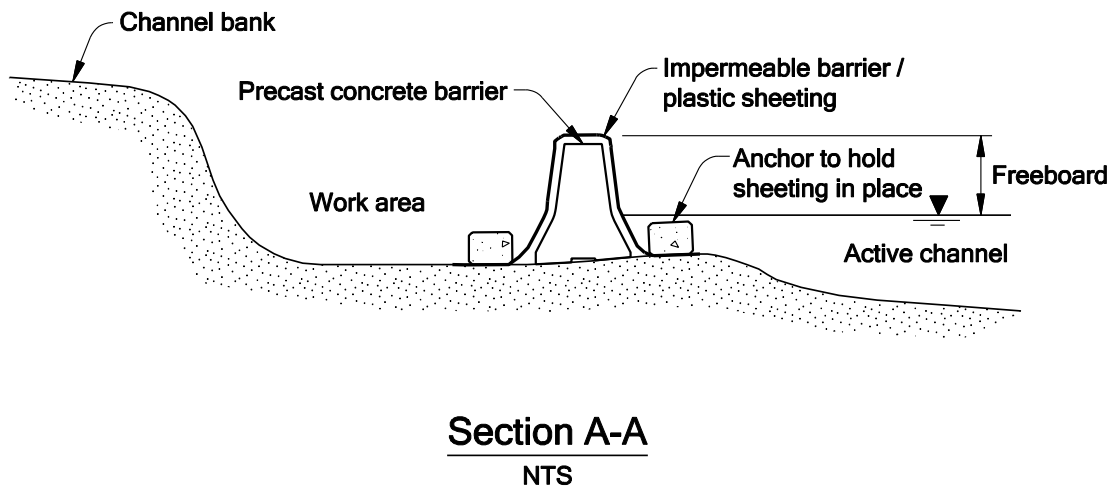
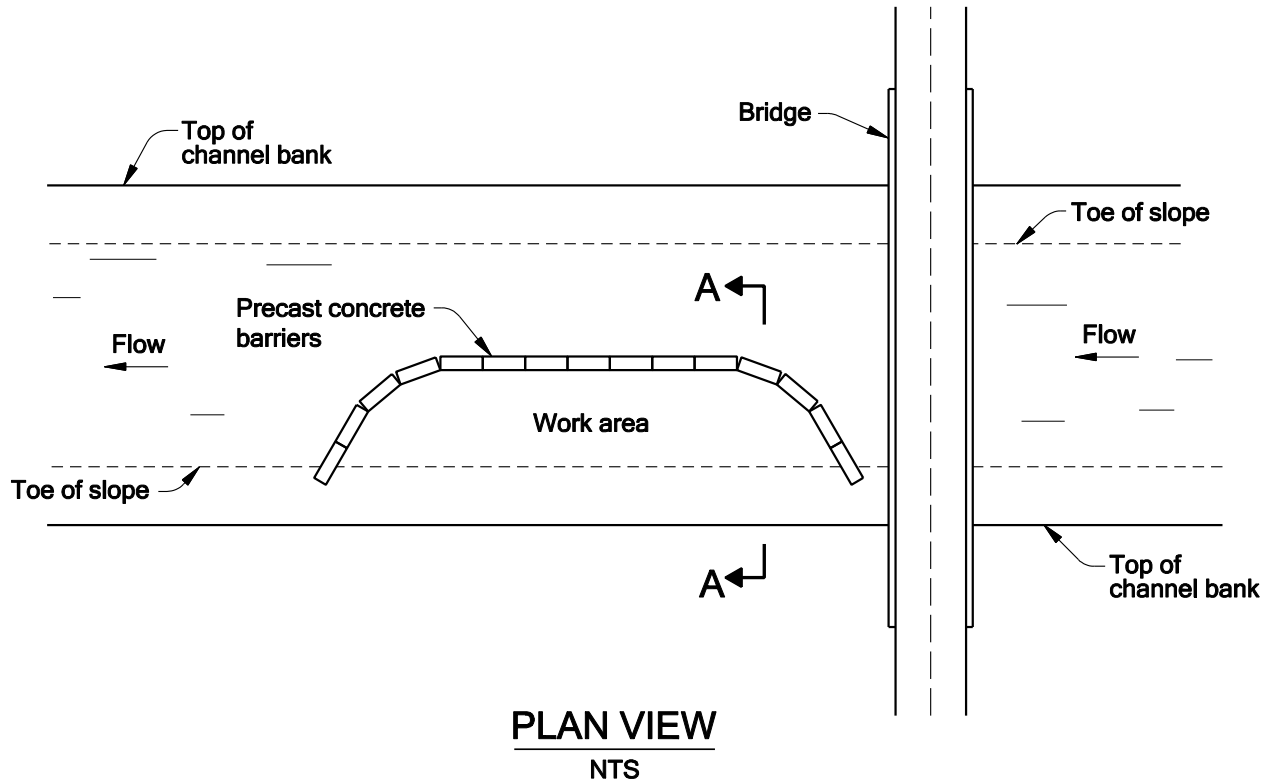


Figure 18-7 Precast Concrete Barriers

18.5.1.3 Water-filled Impervious Membrane

Geo-membrane tubes are available that can be filled with water to form a dam. See Figure 8. These water filled tubes are gravity dams using the weight of water to provide stability.

Advantages:

- Can accommodate long lengths of barrier protection
- Low bearing pressure on the bedding surface
- Quick and easy to install
- Tears can usually be repaired while in use
- Flexible enough to accommodate minor terrain slope changes
- Reusable

Disadvantages:

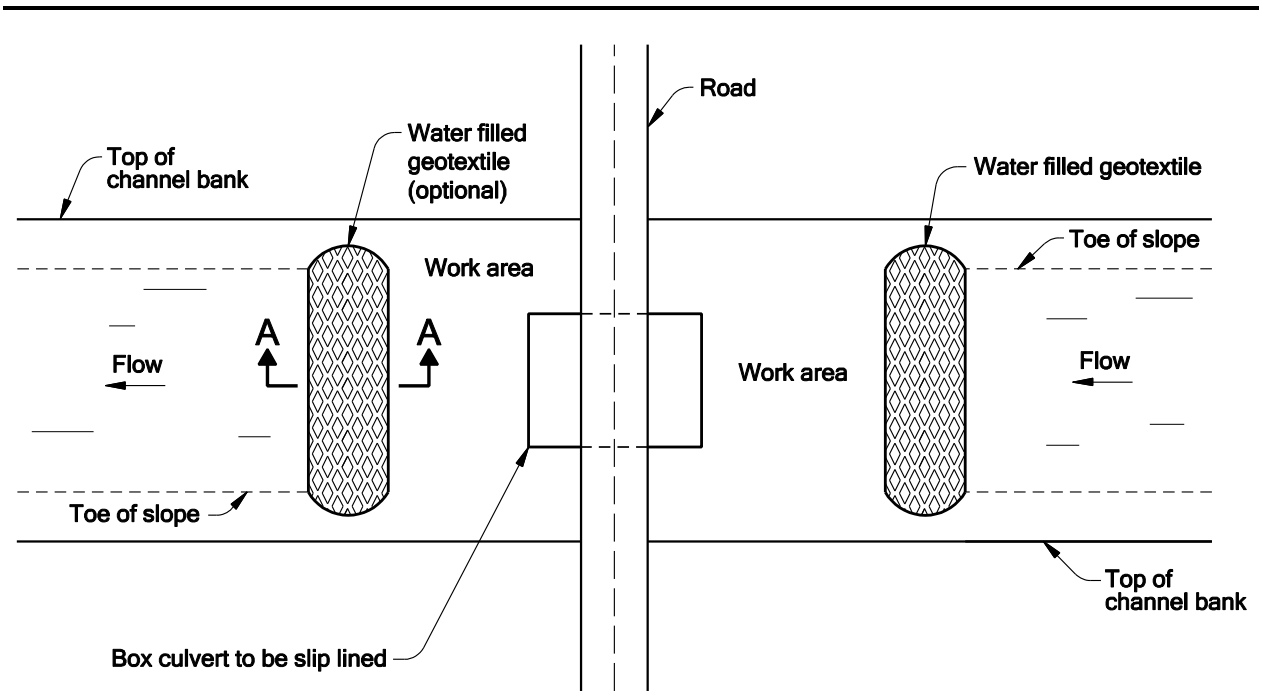
- Limited to relatively flat terrain
- Susceptible to tears that could lead to barrier failure
- High seepage under barrier is likely if used along gravel or cobble channel bottoms
- Low resistance to sliding in most water current conditions

Implement into the concept plan utilizing a few common guidelines:

- Appropriate along level sections of ground
- Appropriate for sandy channel bottoms
- Can be ordered in custom sizes up to 72 inches in height
- Likely stability failure: sliding

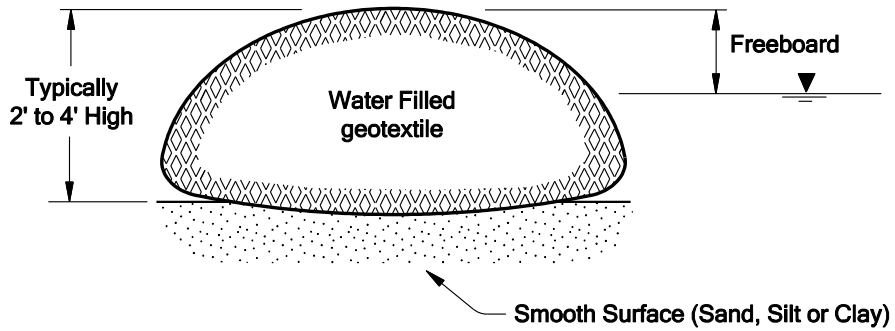


Photo example of Water Filled Impervious Membrane



PLAN VIEW

NTS



Section A-A

NTS

Figure 18-8 Water-filled Impervious Barriers

18.5.1.4 Silt Curtains and Fences

Silt curtains and fences are used for working in wet applications. A curtain or fence is installed around the work area to contain the sediment laden water. The curtain or fence barrier allows suspended soil particles to settle out of suspension and stay in the immediate area.

Silt curtains are suspended between the water surface with a float on top and ballast in the bottom. See Figure 9.



Photo example of Silt Curtain

Advantages:

- Can accommodate varying lengths of barrier protection
- Flexible barrier that can be installed around a work area

Disadvantages:

- Limited to calm water conditions
- Susceptible to tears that could lead to barrier failure

Implement into the concept plan utilizing a few common guidelines:

- Limit installation configuration to a semicircle or U-shaped (Figure 9)
- Spanning a curtain from bank to bank is not recommended unless negligible flow
- Limit use to velocity conditions less than 0.5 ft/sec

- Water depth limits: greater than 2.5 feet but less than 20 feet
- Wave height limits: less than 0.5 feet
- Likely stability failure: sliding

Silt Fences are staked in place and the barrier fabric is anchored to the stakes with staples or nails. The bottom of the barrier fabric is ballasted to create a seal against the stream bottom. See Figure 9.

Advantages:

- Can accommodate varying lengths of barrier protection
- Flexible barrier that can be installed around a work area

Disadvantages:

- Limited to calm water conditions
- Challenging to install when water is present
- Susceptible to tears that could lead to barrier failure

Implement into the concept plan utilizing a few common guidelines:

- Limited to shallow depth conditions and low water current/velocity
- Spanning a silt fence from bank to bank is not recommended unless negligible flow
- Limit use to velocity conditions less than 0.5 ft/sec
- Water depth limits: 4 feet or less
- Wave height limits: less than 0.5 feet
- Likely stability failure: overturning, sliding

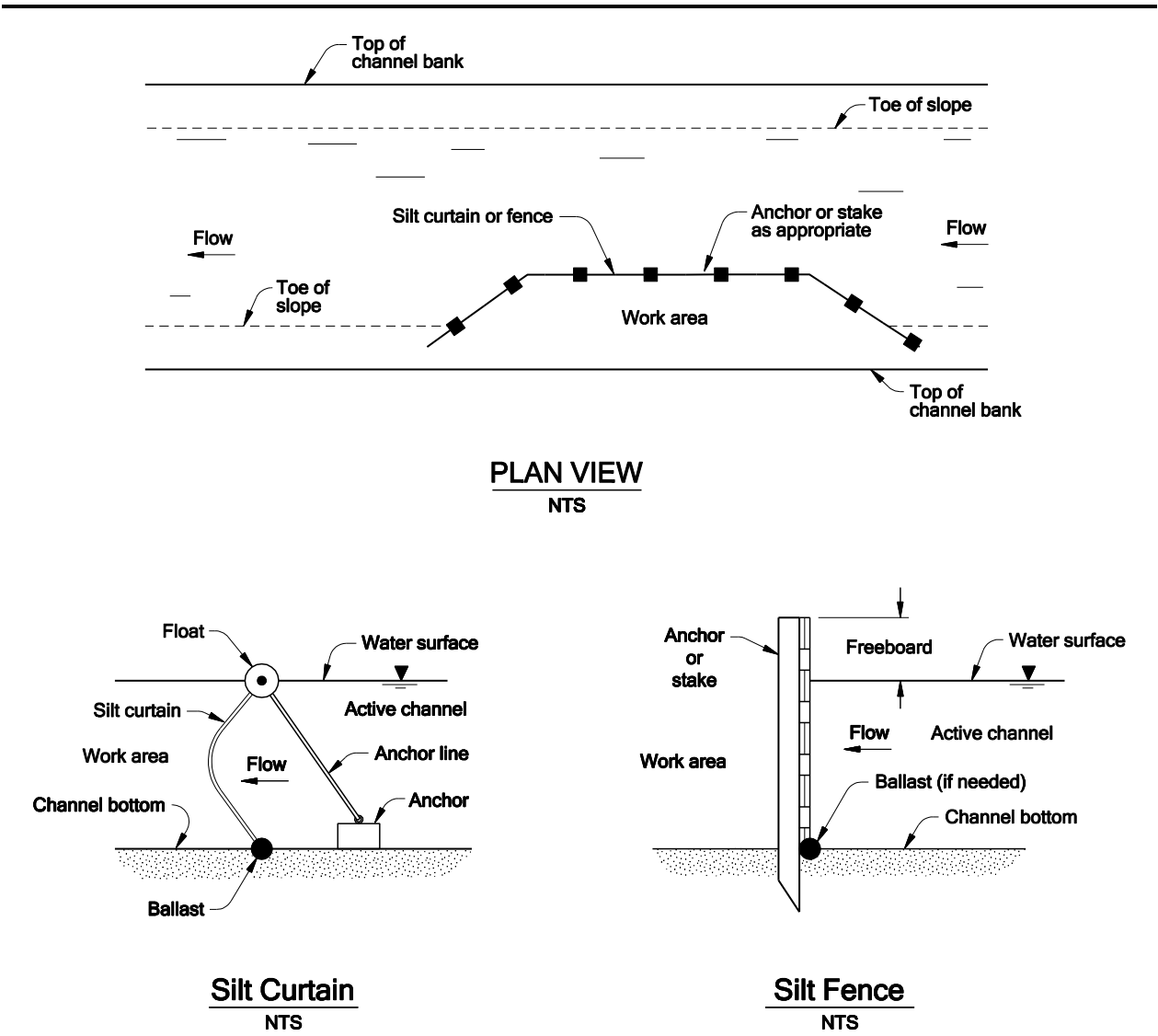


Figure 18-9 Silt Curtain and Fence Barriers

18.5.1.5 Sheet Piles

Sheet piles can be used by driving it into the ground to form an enclosed area (also known as a cofferdam) around the excavation site. Sheet piles are a manufactured construction product with a mechanical connection “interlock” at both sides of the section. These mechanical connections interlock with one another to form a continuous wall of sheeting. Sheet pile applications are typically designed to create a rigid barrier for earth and water, while resisting the lateral pressures of those bending forces. The shape or geometry of a sheet pile section lends to the structural strength. Also, the soil in which the section is driven has numerous mechanical properties that can affect the performance.

In some cases an underwater concrete seal may be needed along the channel bottom within the cofferdam to seal off water and resist its pressure, and also to act as a slab to brace against the inward movement of the sheet piles in order to mobilize their resistance to uplift under the hydrostatic pressure. Figure 10 illustrates sheet pile cofferdams to isolate the center pier of a bridge.

Advantages:

- Sheet piles are easily installed and removed
- Materials can typically be reused

Disadvantages:

- Requires special equipment (impact or vibratory hammer) and access for installation and removal

TWM concept plans do not apply to coffer dam installations. The Contractor's Engineer will need to submit plans, calculations, and working drawings that must comply with ODOT's Bridge Design and Drafting Manual. The most current Bridge Design and Drafting Manual can be viewed at the following website:

http://www.oregon.gov/ODOT/HWY/BRIDGE/Pages/standards_manuals.aspx

Also keep in mind:

- An ODFW Fish passage plan (application) may be needed for this type of work. The project environmental coordinator or biologist will be requesting design drawings and assistance with stream crossing information. A link to view the fish passage plan application is provided below:
<http://www.dfw.state.or.us/fish/passage/>
- The design may need to meet ODFW's requirement of at least one clear span of 35 feet within the channel for channels wider than 35 feet.

Cofferdam designs must comply with Standard Specification 00510 and the checklist outlined in Special Provision SP510. Special Provision SP510 can be viewed and downloaded at the following website:

http://www.oregon.gov/ODOT/HWY/SPECS/Pages/2008_special_provisions.aspx#Part_00500

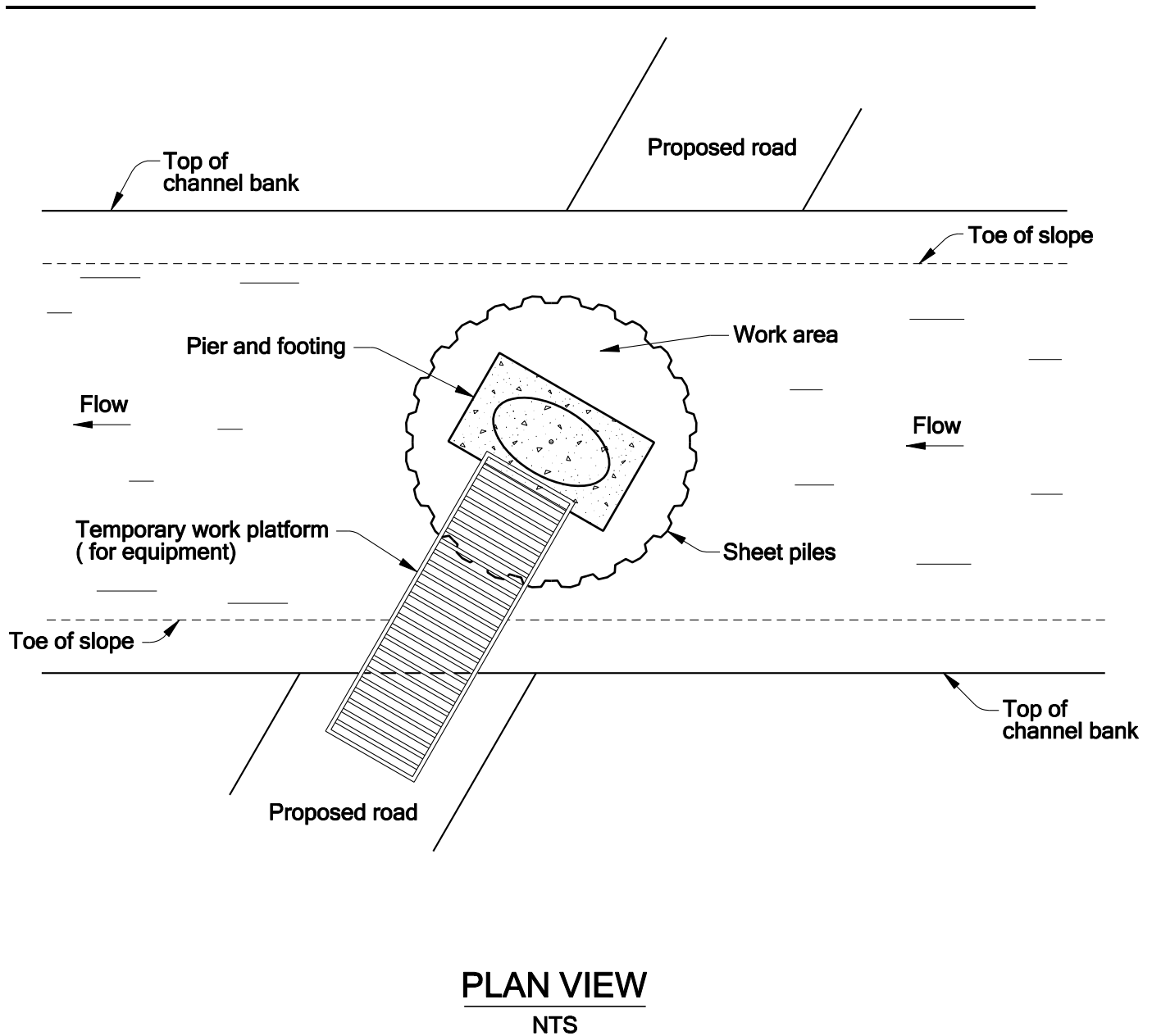


Figure 18-10 Sheet Pile Barriers

18.5.2 Soil Stability Analysis

The site soil conditions should be considered for the varying TWM component options. Soil conditions may be a controlling factor in the determination of which type of components may be suitable for the site. There may be numerous forces that a barrier would have to withstand when installed to separate a work area from an active stream or creek channel. Hydrodynamic forces

are exerted during times when streamflow is present around the barrier. Among the forces are positive frontal pressure forces against the barrier and/or drag effect along the sides. Hydrostatic forces can induce horizontal forces against a barrier, especially when water levels on different sides of the barrier are not equal. It can even cause vertical buoyant forces or flotation. Therefore, proper stability analysis and barrier design must be sought for forces related to sliding, overturning, and settlement.

TWM facilities are usually short term structures and may need very minimal design evaluation to provide adequate and safe isolation of the work area. Sound engineering judgment should be used when determining the level of evaluation needed for the individual site conditions.

The project Geotechnical Engineer should be consulted for the soil stability analysis with hydraulic input parameters provided by the hydraulic designer. The hydraulic parameters that will need to be provided are as follows:

- Maximum water pressure acting on the base of the structure
- Horizontal force of water acting on the structure
- Vertical uplift force of retained water acting on the structure
- Total nominal effective force on the base of the structure

Factor of safety against sliding

Sliding or the movement of TWM barriers is due to moving water exerting pressure forces greater than inherent resistive forces.

The factor of safety against sliding is calculated using basic fluid mechanics pressure-related equations:

Maximum water pressure, acting at the structure's base is calculated using the following equation:

$$P_w = H_w \gamma_w \quad (\text{Equation 1})$$

Where:

$$\begin{aligned} P_w &= \text{maximum water pressure at the base of the structure} \\ H_w &= \text{height of the retained water} \\ \gamma_w &= \text{unit weight of the water} \end{aligned}$$

Horizontal force of the water acting on the structure is calculated using the following equation:

$$F_h = \frac{1}{2} P_w H_w = \frac{1}{2} \gamma_w H_w^2 \quad (\text{Equation 2})$$

Where:

$$\begin{aligned} F_w^h &= \text{horizontal force on the structure due to the pressure of retained water} \\ H_w &= \text{height of the retained water} \\ \gamma_w &= \text{unit weight of the water} \end{aligned}$$

Vertical uplift force of retained water acting on the structure is calculated using the following equation:

$$F_w^v = \frac{1}{2} \rho_w \frac{B}{B+L} B = \frac{1}{2} \gamma_w H_w \frac{B^2}{B+L} \quad (\text{Equation 3})$$

Where:

$$\begin{aligned} F_w^v &= \text{vertical uplift force on the structure due to the pressure of retained water} \\ H_w &= \text{height of the retained water} \\ \gamma_w &= \text{unit weight of the water} \\ B &= \text{base width of retaining structure} \\ L &= \text{length of the impermeable blanket} \end{aligned}$$

Total normal effective force on the structure's base is calculated using the following equation:

$$N' = W - F_w^v \quad (\text{Equation 4})$$

Where:

$$\begin{aligned} N' &= \text{vertical effective force on the base of the structure} \\ W &= \text{total weight of the structure (may include the vertical water pressure, acting downward, if the wet face of the structure is not vertical)} \\ F_w^v &= \text{vertical uplift force on the structure due to the pressure of retained water} \end{aligned}$$

Factor of safety against sliding in terms of total forces on the base is calculated using the following equation:

$$F_s = \frac{N' \tan \delta}{T} \quad (\text{Equation 5})$$

Where:

$$\begin{aligned} F_s &= \text{factor of safety against sliding} \\ N' &= \text{vertical effective force on the base of the structure} \\ \delta &= \text{angle of friction of the soil/structure interface. **Coordinate value with project geotechnical designer.**} \end{aligned}$$

Substituting N' and $T = F_w^h$; (the horizontal force on the structure due to the pressure of retained water). The resultant factor of safety is expressed as:

$$F_s = \frac{(W - F_w^v) \tan \delta}{\frac{1}{2} \gamma_w H_w^2} \quad (\text{Equation 6})$$

Where:

- F_S = factor of safety against sliding
- W = total weight of the structure (may include the vertical water pressure, acting downward, if the wet face of the structure is not vertical)
- F_w^v = vertical uplift force on the structure due to the pressure of retained water
- δ = angle of friction of the soil/structure interface. Friction angles vary depending on soil type. **Coordinate value with project geotechnical designer.**
- H_w = height of the retained water
- γ_w = unit weight of the water

Factor of safety against overturning

Overturning is an action, due typically to external forces, whereby a structural element rotates from its original position, or further, to the point where it fails or falls over completely.

Factor of safety against overturning obtained by expressing moment of equilibrium with respect to the structure's downstream toe is calculated using the following equation:

$$F_O = \frac{W r_w}{F_w^h \frac{H_w}{3} + F_w^v \frac{2}{3} B} \quad (\text{Equation 7})$$

Where:

- F_O = factor of safety against overturning
- W = total weight of the structure (may include the vertical water pressure, acting downward, if the wet face of the structure is not vertical)
- r_w = moment arm length
- F_w^v = vertical uplift force on the structure due to the pressure of retained water
- F_w^h = horizontal force on the structure due to the pressure of retained water
- H_w = height of the retained water
- γ_w = unit weight of the water
- B = base width of retaining structure
- L = length of the impermeable blanket

Or, substituting for the moments of F_w^h and F_w^v :

$$F_O = \frac{W r_w}{\frac{1}{6} \gamma_w H_w^3 + \frac{1}{3} \gamma_w H_w \frac{B^3}{B+L}} \quad (\text{Equation 8})$$

Where:

- F_O = factor of safety against overturning
- W = total weight of the structure (may include the vertical water pressure, acting downward, if the wet face of the structure is not vertical)
- r_w = moment arm length
- H_w = height of the retained water
- γ_w = unit weight of the water

B = base width of retaining structure

Settlement

Related to civil engineering and this discussion on TWM, settlement is more associated with soil mechanics, foundation and geotechnical engineering. It is often facilitated by groundwater seepage from outside of, toward and beneath a structural barrier. The upward force of water beneath the barrier, or the transfer of fines and consolidation of soils, resulting from groundwater movement may cause a TWM barrier to settle. TWM barriers are most often small, short term structures in which settlement would not be of much concern for the functionality of the structure nor for the safety of workers within the isolated work area. In situations where taller or multiple layers of barrier components are needed, possible settlement should be analyzed. Foundation settlement is commonly calculated in accordance with AASHTO Article 10.6.2.4 and Chapter 6 and Chapter 8 of the GDM. See the ODOT GDM, Section 15.4.3.6.2.

A soil evaluation and subsoil exploration of the streambed materials should be performed as part of the project geotechnical investigation and gathering of data, and should be reviewed to determine the effect it will have on stability analysis and barrier placement. See the ODOT Geotechnical Design Manual (GDM), Chapters 3 and 15, for information related to performing a geotechnical investigation. Also see GDM Chapter 16, Tables 16.2, 16.3 and Figure 16.2, pertaining to soil types and information about the angle of internal friction. Also, review the ODOT Hydraulic Design Manual (HDM), Chapter 6, Section 6.4.4.10 and Appendix A for further discussion of bed materials.

Design concerns with varying soil types:

- Certain types of bed material could cause the barrier to settle. This could occur when soft clays or silts are present at the site of interest.
- Channels lined with bedrock material tend to have a low coefficient of friction. Barrier anchoring may be needed when the bed material is bedrock.
- Channels lined with large gravel, cobbles and/or boulders tend to have an irregular bed surface. This condition makes it challenging to use a barrier that can prevent or control surface water intrusion into the construction area. Channel bed preparation may be needed to provide a suitable foundation to place the barrier.

18.5.3 Stream Flow Control

There are several functional requirements that have to be satisfied when implementing stream flow control. The first requirement is to utilize a stream flow feature that can be implemented with the type of work proposed while maintaining a dry construction area. For example, a bypass pipe and/or pump are needed when implementing full isolation. The second requirement is that it must be able to convey streamflow through or around the work area for the duration of

the project to maintain a continuous flow condition that prevents the downstream channel from drying up causing injury to or killing aquatic life.

ODOT has utilized existing stream channel, pipes, and pumps to route streamflow through or around the work area. The use of any one or a combination of these stream flow features depends on site conditions (topography, debris, and access limitations), channel characteristics (such as width, depth and channel slope), flow velocity conditions, duration of work, and the type of work. Additional discussion in the followings sections is intended to help with implementing the best stream flow control approach according to the anticipated challenges of a project site.

18.5.3.1 Existing Channel

The use of the existing stream channel is the ideal approach to convey water around the work area. It can be used for stream flow conveyance when the work occurs along the bank or work is staged so that an isolation barrier does not span the entire width of the channel. See Photo 1 and 2.



Photo 1



Photo 2

Advantages:

- Can accommodate varying flow and velocity conditions
- Upstream and downstream fish passage is provided for the duration of the project
- Bypass pipe and/or pump is not needed to convey water around the work area

Disadvantages:

- Cannot be implemented when work occurs in the channel from bank to bank (full isolation)

Implement into the concept plan utilizing a few common guidelines:

- Channel conditions along the active channel needs to be able to convey the concentrated flow
- Only implement during non-flood periods

18.5.3.2 Gravity Bypass Pipes

A gravity bypass pipe system is another option to route water through or around a work site. The pipe would begin at the upstream isolation barrier and be placed along the channel bottom. The bypass pipe would extend through the work area and end at a point downstream of the work area.



Photo A



Photo B



A bypass pipe can be used during stream crossing structure (culverts and bridges) repairs and replacements (see photos A, B and C above), or for channel work downstream of a culvert (see photo D, above).

The bypass configuration approach depends on the construction or repair activities. Here are a few examples for reference:

- *Stream crossing culvert replaced with a new culvert (see photo A above):* **Option 1** is that the new culvert will be placed at the same location and is utilizing a bottomless structure approach. An option to maintain stream flow is to drain water through a bypass pipe. The bypass pipe would be placed along the existing culvert and channel bottom and span the entire length of the work area. The bypass pipe would begin at the upstream barrier and end far enough downstream to maintain a dry work area. **Option 2** is that the new culvert will be placed adjacent to the existing culvert to improve channel alignment. This option would allow for the existing culvert to function as the bypass pipe or a pipe can be placed inside of the existing pipe.
- *Stream crossing culvert replaced with a new bridge example (see photo B above):* In most cases the new bridge will be placed at the same location as the existing culvert. One construction option would be to build the bridge over the existing culvert. The existing culvert would be removed as soon as the bridge can support traffic loading. An option to maintain streamflows through the project site is to drain water through a bypass pipe. The bypass pipe would begin at the upstream barrier and then be routed through the existing culvert structure during construction. The end of the bypass pipe would be located far enough downstream to maintain a dry work area.
- *Channel reconstruction to install a roughened channel (see photo D above):* A roughened channel is a construction option to raise and restore the streambed downstream of a stream crossing structure such as a culvert or bridge when a headcut has proceeded upstream

through the crossing site or a scour hole has evolved influenced by the erosive forces of streamflows exiting the structure. A barrier is placed at the culvert outlet. The bypass pipe would be installed into the barrier to direct stream flows into it and extend through the work area during construction. The end of the bypass pipe would be located far enough downstream to maintain a dry work area. Note this option is primarily used when the existing crossing structure will remain in-place.



Photo examples of piping the stream flow through the existing structure

Advantages:

- Flexible enough to accommodate minimum terrain slope
- Can accommodate short or long conveyance distances between pipe inlet and outlet
- Reusable
- Quick and easy to install

Disadvantages:

- It is typically located along the work area and may need to be relocated to avoid equipment or construction work
- Upstream fish passage is difficult because low water depth and high velocities can occur

Implement into the concept plan utilizing a few common guidelines:

- Site conditions must provide moderate slope installation to generate adequate velocity to move water through bypass pipe

- Discharge point must be able to accommodate an energy dissipator. See section 18.5.3
- An oversized pipe is desirable to accommodate varying streamflows and would allow for sufficient bypass flow to maintain aquatic life downstream
- Upstream fish passage through a bypass pipe may not be possible because of higher velocity conditions due to confining the flow in a pipe

18.5.3.3 Pumps

There are pumps suited for the construction industry. These pumps typically are able to quickly move a high volume of water (performance), have the ability to pass debris without clogging (low downtime), and can withstand harsh work environments (durability). TWM work could utilize these pumps to dewater work areas (i.e., between barriers) or route streamflows around the work area or to a sediment control facility for sediment removal treatment.



Photo examples of pumped bypass

There are generally two types of water pumps in the construction industry. The first type of pump is the centrifugal pump. This type of pump uses a rotating impellor to draw water into the pump and pressurize the discharge flow. Common centrifugal rental pumps include standard, trash, submersible models. The second type of pump is the positive displacement pump. The most common displacement pump is the diaphragm pump. These pumps deliver a fixed amount of flow per cycle through the mechanical contraction and expansion of a flexible diaphragm.

Standard centrifugal pumps

Standard centrifugal pumps provide an economical option for general purpose dewatering. The most common models are in the 2 to 4-inch range with flows up to 500 gallons per minute (gpm)

and heads in the range of 90 to 115 feet. These pumps should only be used in clear water applications as they have limited solid handling capability of only 10 percent by volume.

High-pressure centrifugal pumps

High pressure centrifugal pumps are designed for use in applications requiring high-discharge pressures and low flows. These pumps will discharge around 145 gpm and produce heads in excess of 300 feet. These pumps should not be used when water contains any solids or even sandy water. Silt, sand or debris would almost immediately clog the pump. A mesh net would need to be used over the suction strainer if the pump is being used in dirty water.

Trash centrifugal pumps

Trash pumps are a type of self-priming centrifugal or submersible centrifugal pump designed to handle dirty water containing rocks, mud, stone, and other debris while dewatering. A key feature is open or non-clog enclosed impellers designed to pass rocks and other debris. Trash pumps are commonly used to dewater construction sites, mines, and utility pits. The most common pump sizes are in the 2 to 6-inch range producing flows from 200 to 1,600 gpm and total head (pressure) ranges of 25 to 150 feet.

The rule of thumb is that a trash pump will handle spherical solids up to $\frac{1}{2}$ the diameter of the suction inlet. Solids such as sticks, stones, and debris flow through without clogging. Trash pumps can handle up to 25 percent suspended solids by volume.

Diaphragm pumps

Diaphragm pumps use positive displacement rather than centrifugal force to move water through the casing. In other words the pump will deliver a specific amount of flow per stroke, revolution or cycle.

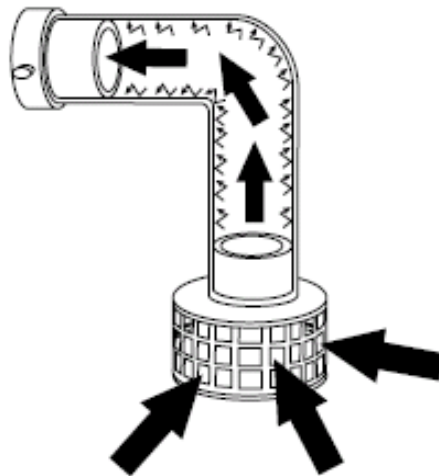
Diaphragm pumps are commonly referred to as mud hogs, mud hens and mud suckers. Their names reflect their popularity for use in applications where shallow depths and slurry water render centrifugal pumps ineffective.

A diaphragm pump provides the lowest rate of discharge and head by comparison of any contractor pump. The most common pumps are the 2 and 3-inch gasoline powered models producing flows in the range of 50 to 85 gpm. They have the ability to handle air without losing their prime and of handling water with a solid content greater than 25 percent by volume.

Slow-seepage applications are the most common uses for diaphragm pumps. These conditions exist in any trench or excavation where groundwater seeps slowly into the work site and in areas with high water tables. In these environments centrifugal pumps are unable to perform effectively because their high-discharge volumes combined with low water levels would cause the pumps to quickly lose their prime.

Pump terminology

- Pumps lift water with the aid of atmospheric pressure then pressurize and discharge it from the casing. The practical suction lift (also known as maximum suction lift) is 25 feet (at sea level and for cold water [60°F]).
- Pump performance is measured in volume as *gallons per minute* and in pressure as *head*. In general a trade off occurs between head and flow with an increase in head causing a decrease in flow or vice versa.
- Head refers to gains or losses in pressure caused by gravity and friction as water moves through the system (see figure below). It can be measured in lbs/in² (PSI) but is most commonly listed in feet of water.



Friction loss

For example, a 3-inch trash pump is rated with a maximum head of 90 feet. A pump must produce 1 psi to push a column of water vertically 2.31 feet. Therefore dividing the maximum head rating of a pump 2.31 will provide the maximum pressure capacity of the pump:

$$90 \text{ (ft/head)} / 2.31 \text{ (ft/head)} = 38.96 \text{ psi}$$

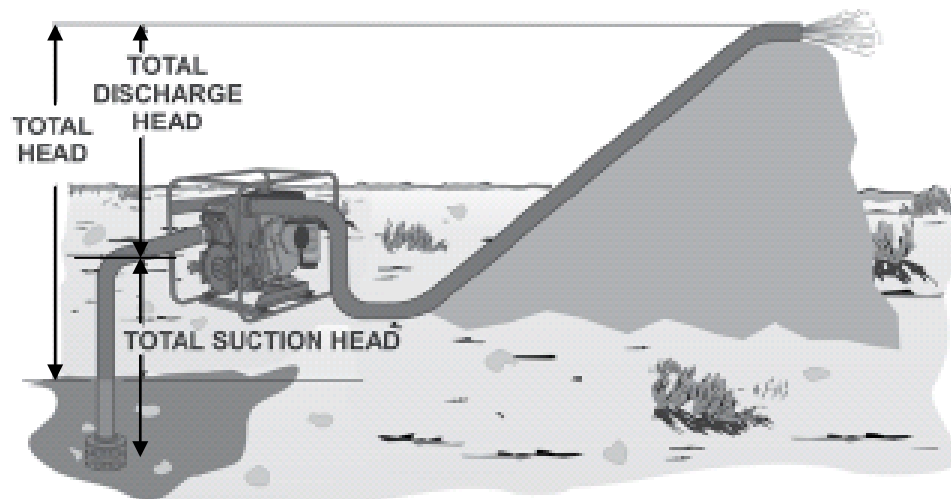
or

Multiplying 2.31 by the maximum pressure capability of the pump will provide the maximum head rating of the pump.

$$2.31 \text{ (ft/head)} \times 38.96 \text{ psi} = 90 \text{ (ft/head)}$$

Suction lift and head may also be referred to as static or dynamic. Static indicates the measurement does not take into account the friction caused by water moving through the hose or pipes. Dynamic indicates that losses due to friction are factored into the performance. The following terms are usually used when referring to lift or head:

- Static suction lift – the vertical distance from the water line to the centerline of the impeller.
- Static discharge head – the vertical distance from the discharge outlet to the point of discharge or liquid level when discharging into the bottom of a water tank.
- Dynamic suction head – the static suction lift plus the friction in the suction line. Also referred to as total suction head.
- Dynamic discharge head – the static discharge head plus the friction in the discharge line. Also referred to as total discharge head.
- Total dynamic head – the dynamic suction head plus the dynamic discharge head. Also referred to as total head.



Pump implementation guidelines:

- Pump size estimation is based on the design and check discharges determined in design procedure step 3.

- Suction lift is reduced at higher elevations because atmospheric pressure decreases. For example, a pump is capable of a suction lift of 25 feet at sea level compared to 19 feet of suction lift at an altitude of 4,000 feet. Refer to manufacturer’s literature for additional information.
- Altitude affects engine performance as well. A rule of thumb is that gasoline and diesel engines will lose 3 percent of their power for every 1,000 feet of elevation. This is due to the lack of oxygen at higher altitudes.
- Fish passage cannot be provided during pumping operations. Pumps should only be considered when gravity flow conditions cannot be provided or as temporary backup to convey stream flow around the work area.
- Fish screen attached to the intake pipe is required during pumping operations. Incorporate when necessary the fish screen detail and notes onto the concept plan as discussed in the drafting standards at the end of this chapter.
- Pump motors with 150 feet of any stream shall be placed within a contained area in the case of a fuel or oil spill.
- The table below details the ideal pump based on water conditions at the work site:

Application	Standard Centrifugal pump	Diaphragm pump	Trash pump
Clear water	X		
Slimy water	X	X	X
Muck water	X	X	X
Mud water	X	X	X
Silt water	X	X	X
Slow seepage water		X	

Water Intake/Fish Screening

When pumps are used in TWM operations, fish screens shall be installed, operated, and maintained for each water intake, including pumps used to isolate in-water-work areas. Fish screening needs to meet NMFS fish screen regulations.

<https://www.fisheries.noaa.gov/west-coast/habitat-conservation/west-coast-federal-energy-regulatory-commission-licensed>

When pumping water from any body of water, pump intakes shall be equipped with fish screens having a minimum open area of 27% and meet the following requirements:

- Perforated plate openings shall be 3/32 inch or smaller.
- Mesh or woven wire screen openings shall be 3/32 inch or smaller in the narrowest direction.
- Profile bar screen or wedge wire openings shall be 1/16 inch or smaller in the narrowest direction.

18.5.4 Energy Dissipators

Energy dissipators are used to reduce the velocity and, consequently, the erosion potential of flowing water. Their most common use is to reduce the outlet flow velocities from conduits that discharge onto embankments, into natural or unlined channels, or into drainage swales. They are typically permanent installations designed to withstand a design flow without experiencing any damage. The design of permanent application of energy dissipators at the outlets of open-channels or closed conduits such as culverts or storm sewers is discussed in Chapter 11.

Energy dissipators used for TWM need to be simple, easy to install, temporary or removable, have a small footprint, reusable, be able to be installed along the channel bank or bottom, and be able to move or relocate. A few types that provide these features are discussed below.

TWM energy dissipators are often used where:

- erosion may occur
- right-of-way is limited
- a low-cost and easily constructed dissipator is needed
- flow from the outlet of the conduit has moderate to low velocity and depth

18.5.4.1 Temporary Pad using Wood Sheeting

An energy dissipator can be formed using plywood with mounted wood weirs. An example of this temporary dissipator placed downstream from a conduit is shown in Figure 10. When this dissipator is used the flow crosses over the mounted wood weirs before it enters the downstream channel. The energy is dissipated as turbulence when the flow from the upstream conduit collides with the wood weirs mounted to the plywood.



Photo example of Wood Sheet Energy Dissipator

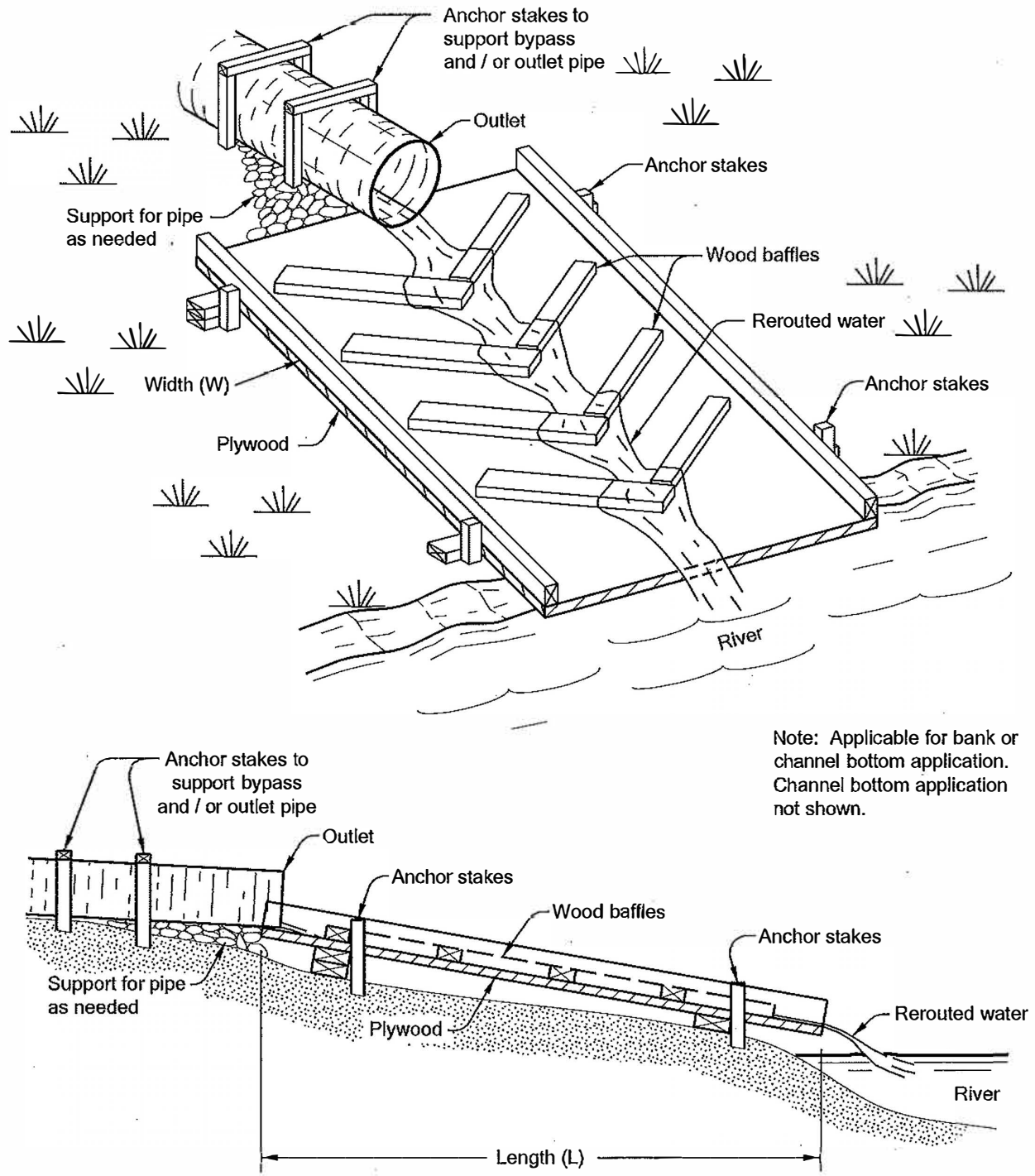


Figure 18-11 Wood Sheet Energy Dissipator

Implement into the concept plan utilizing a few common guidelines:

- Limit the use of this dissipator to bypass or outlet pipes equal to or less than 24-inches in diameter or span.
- Lumber material: must be free of any preservative treatment and coating.
- The minimum surface area needed to accommodate this dissipator:
 - length: 8 feet
 - width: 4 feet

18.5.4.2 Temporary Riprap or Gabion Pads

A riprap pad is the most common permanent type of energy dissipator for smaller conduits or channels. When this dissipator is used the flow crosses over the riprap before it enters the downstream channel. The roughness of the riprap creates turbulence in the flow and energy is dissipated.

A riprap pad to dissipate energy could be used during TWM work. The implementation objective is the riprap pad can be removed at the end of the waterway work. An alternate approach is creating a dissipator pad using a gabion basket filled with riprap. Examples of these temporary concepts are shown in Figures 11, 12 and 13.

Implement into the concept plan utilizing a few common guidelines:

- Riprap and gabion basket: rock must be durable and meet the requirements in the ODOT Standard Specifications for Construction.
- The minimum surface area needed to accommodate this dissipator:
 - length: 4 times the diameter or span of the bypass/outlet pipe
 - width: 2 times the diameter or span of the bypass/outlet pipe
- Riprap size: most temporary applications would utilize Class 50 or 100.
- Pad thickness: 24 inch minimum

Note: Riprap pad design is discussed in Chapter 11

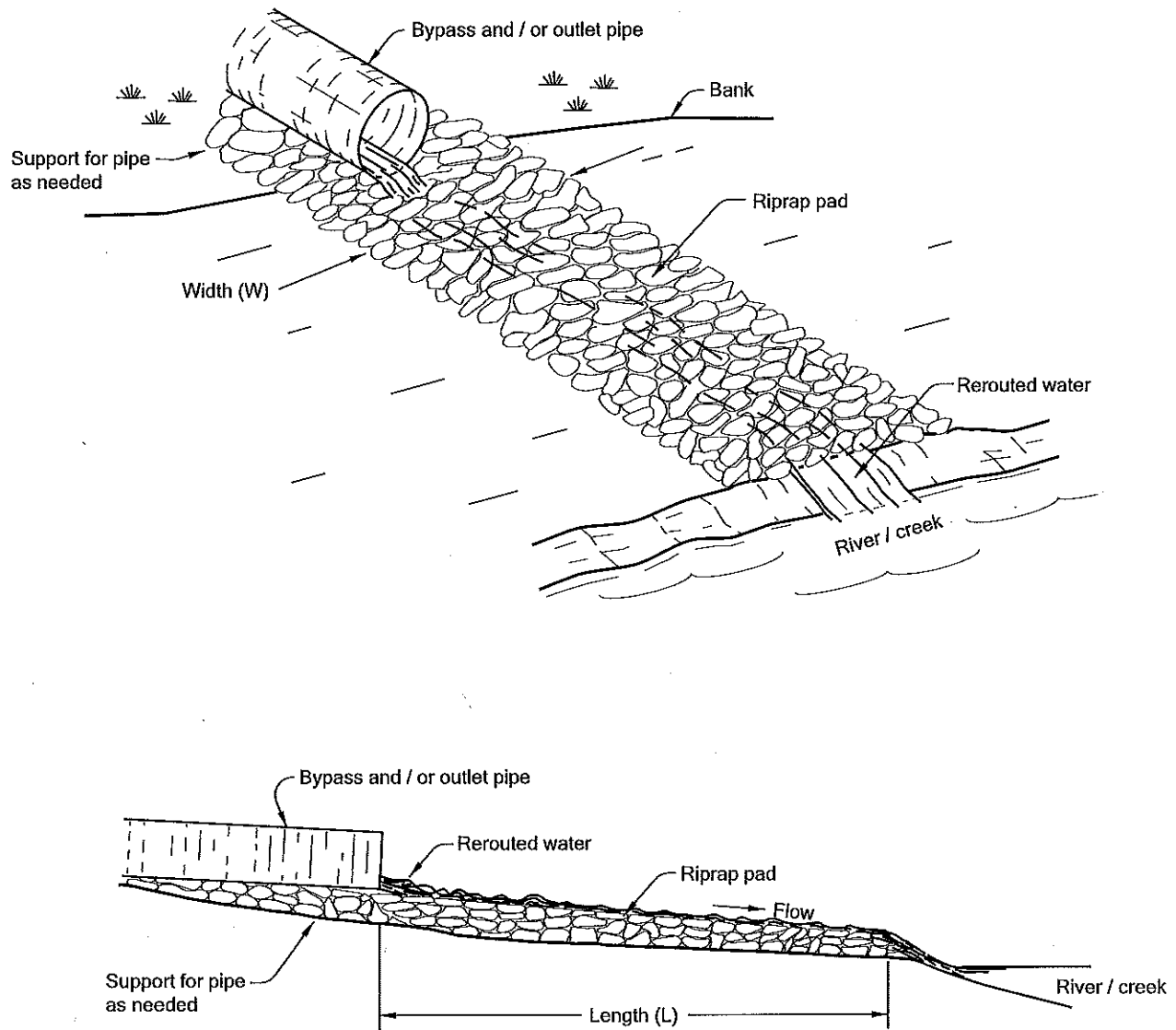


Figure 18-12 Temporary Riprap Energy Dissipator (channel bank application)

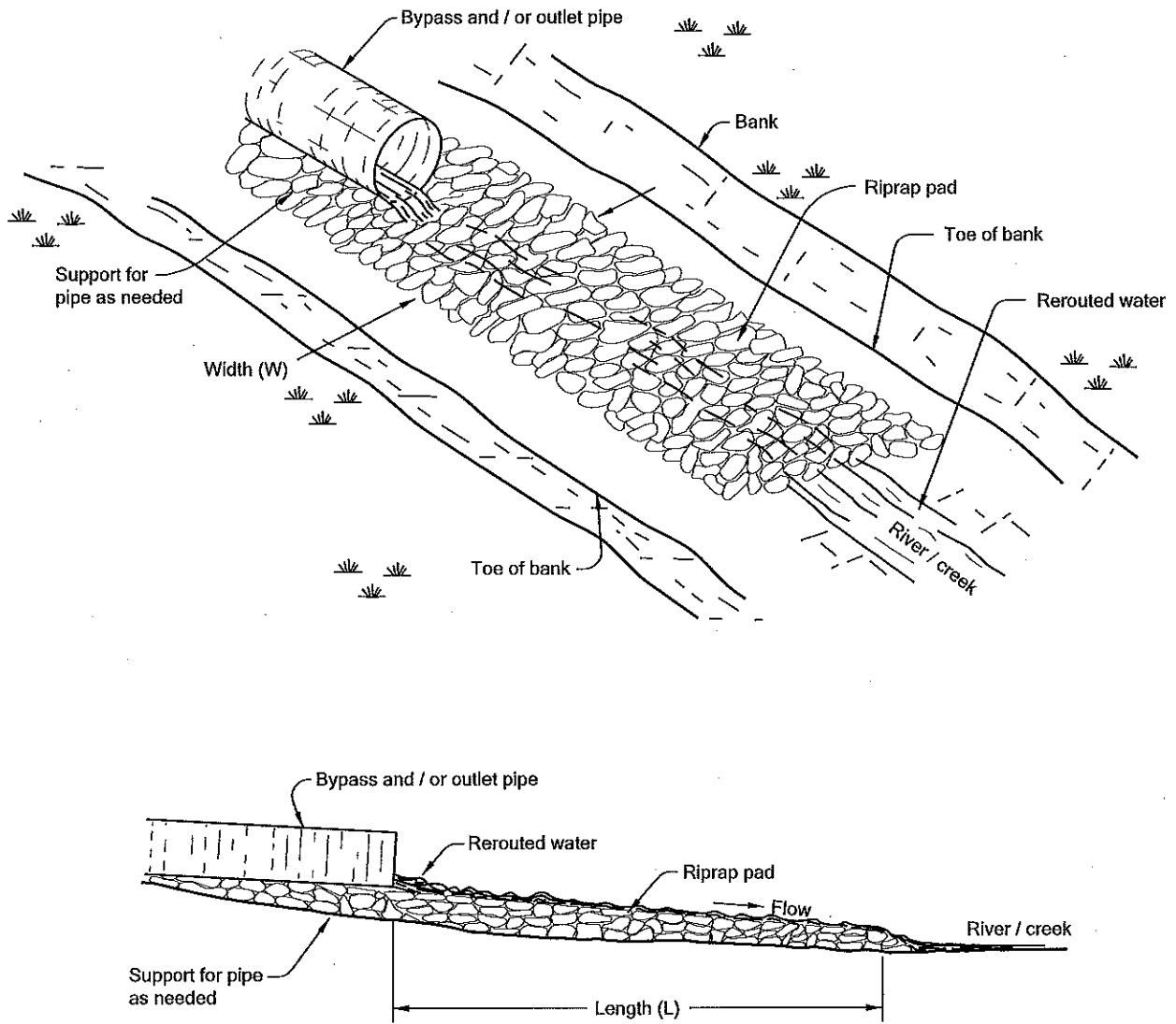
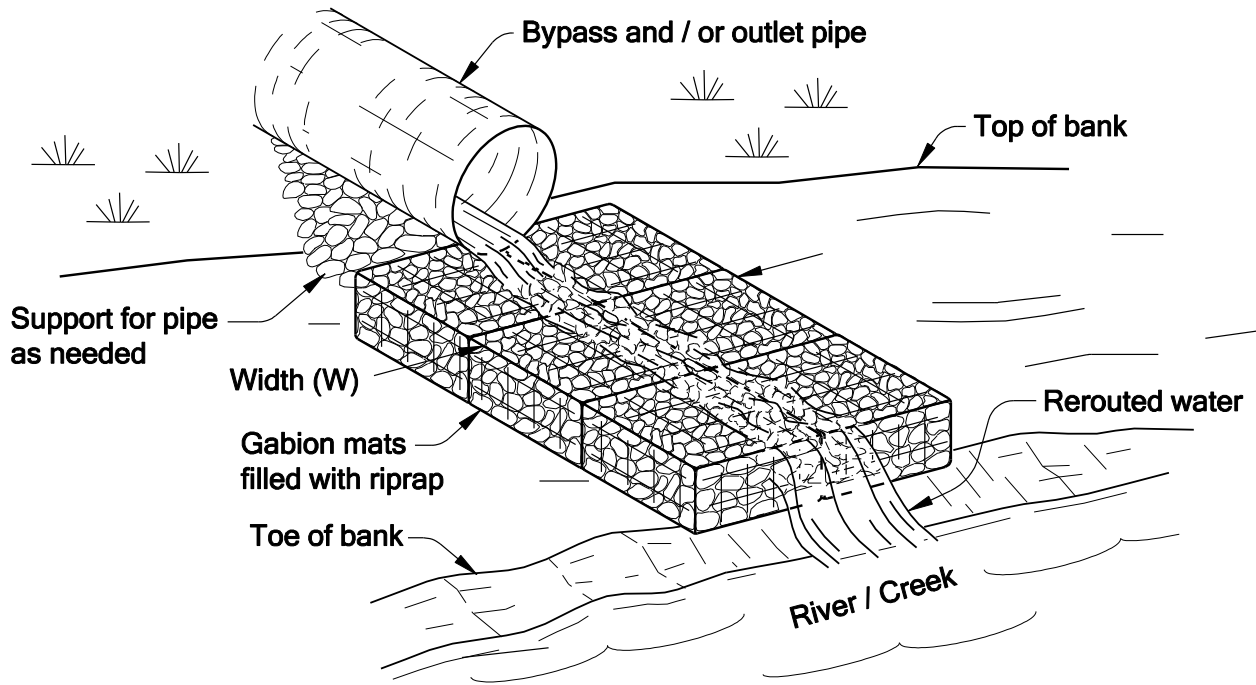


Figure 18-13 Temporary Riprap Energy Dissipator (channel application)



Note: Applicable for bank or channel bottom application. Channel bottom application not shown.

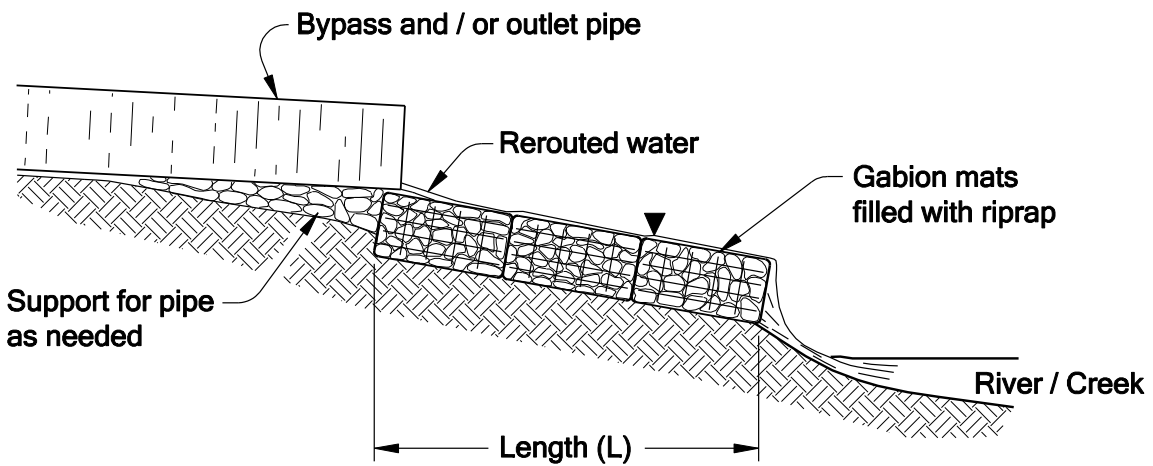


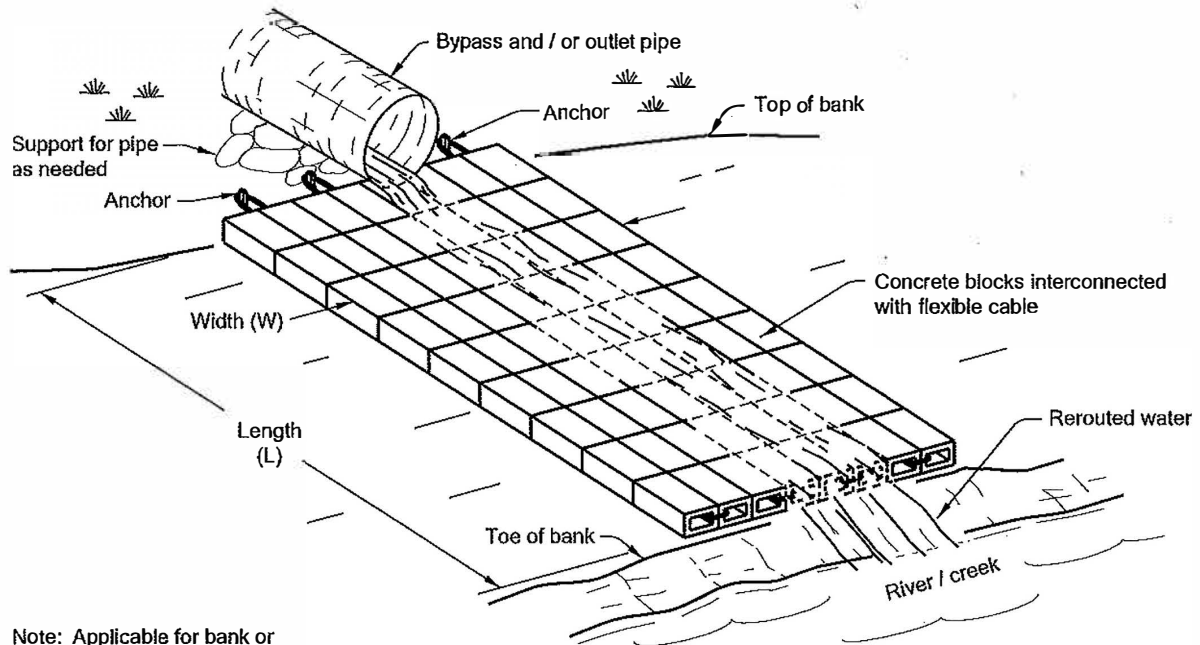
Figure 18-14 Temporary Gabion Energy Dissipator

18.5.4.3 Temporary Concrete Pads

An energy dissipator can be formed using a precast cable concrete block system. It consists of concrete blocks interwoven with stainless steel cable. The cable feature allows this pad to contour to the channel bottom or side slope. Note that a cable concrete pad would have to be placed and moved using heavy equipment. Examples of this temporary dissipator option are shown in Figure 14.

Implement into the concept plan utilizing a few common guidelines:

- The minimum surface area needed to accommodate this dissipator:
 - length: 8 feet
 - width: 2 times the diameter or span of the bypass/outlet pipe
- Blocks must have surface roughness
- Concrete block cable system would simplify installing, relocating, and removing



Note: Applicable for bank or channel bottom application. Channel bottom application not shown.

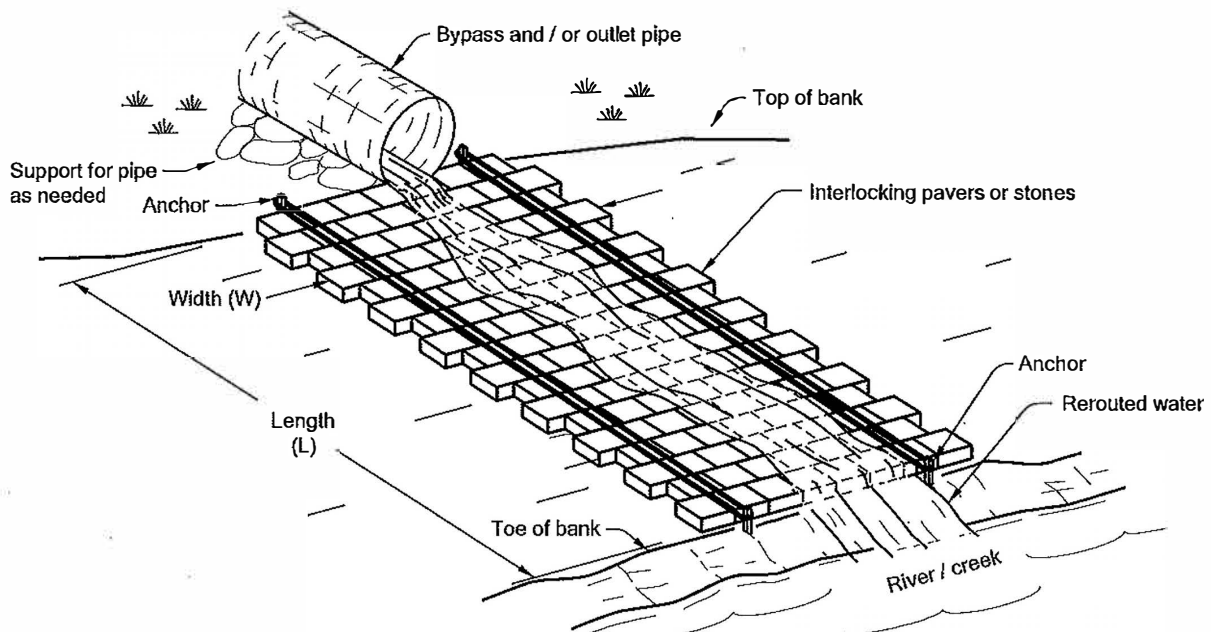


Figure 18-15 Concrete Pad Energy Dissipator

18.5.5 Sediment Control Facilities

Sediment control measures must be implemented if turbidity in the dewatering discharge has the potential to exceed the allowable standard. This allowable standard is set by the regulatory agencies in permits and other approvals. The most common standard is that turbidity cannot be increased more than 10 percent between upstream and downstream reaches, except for nominal periods of time (e.g. 2 hours). Suspended solids trapped in water are the primary water quality issue of concern in all TWM situations.

Sediment control is commonly needed when dewatering the construction work area. These flows are generally pumped to a TWM treatment facility before releasing back into the waterway. It may also be necessary to route water pumped from the waterbody to a TWM treatment facility if sediment levels are high.

Use of any one of these sediment control measures removes low-to-medium levels of sediment. A combination of these measures should be used if high levels of sediment are encountered during dewatering and construction.

Note possible facility locations on the TWM plan. Flat to mild slope areas provide the best conditions for pollutant removal performance.

Note possible treatment option(s) on the TWM plan. The treatment options must remove sediments by settling or filtering. A few sediment control measures that are effective at removing sediments by settling or filtering are discussed below.

18.5.5.1 Filter Bags

Filter bags are large rectangular or square bags made of heavy-duty needle punched filter fabric that provides high permittivity pore structure that allows filtered water to pass through the fabric while sediments are captured in the bag. These bags are commonly used during water pumping applications. These bags are generally known as dewater bags or sediment filter bags. See Figure 15.

These filter bags are rugged but not indestructible. Proper performance depends on maintaining a reasonable pump rate and ensuring concentration of sediment is not excessive otherwise the filter bag will fail.

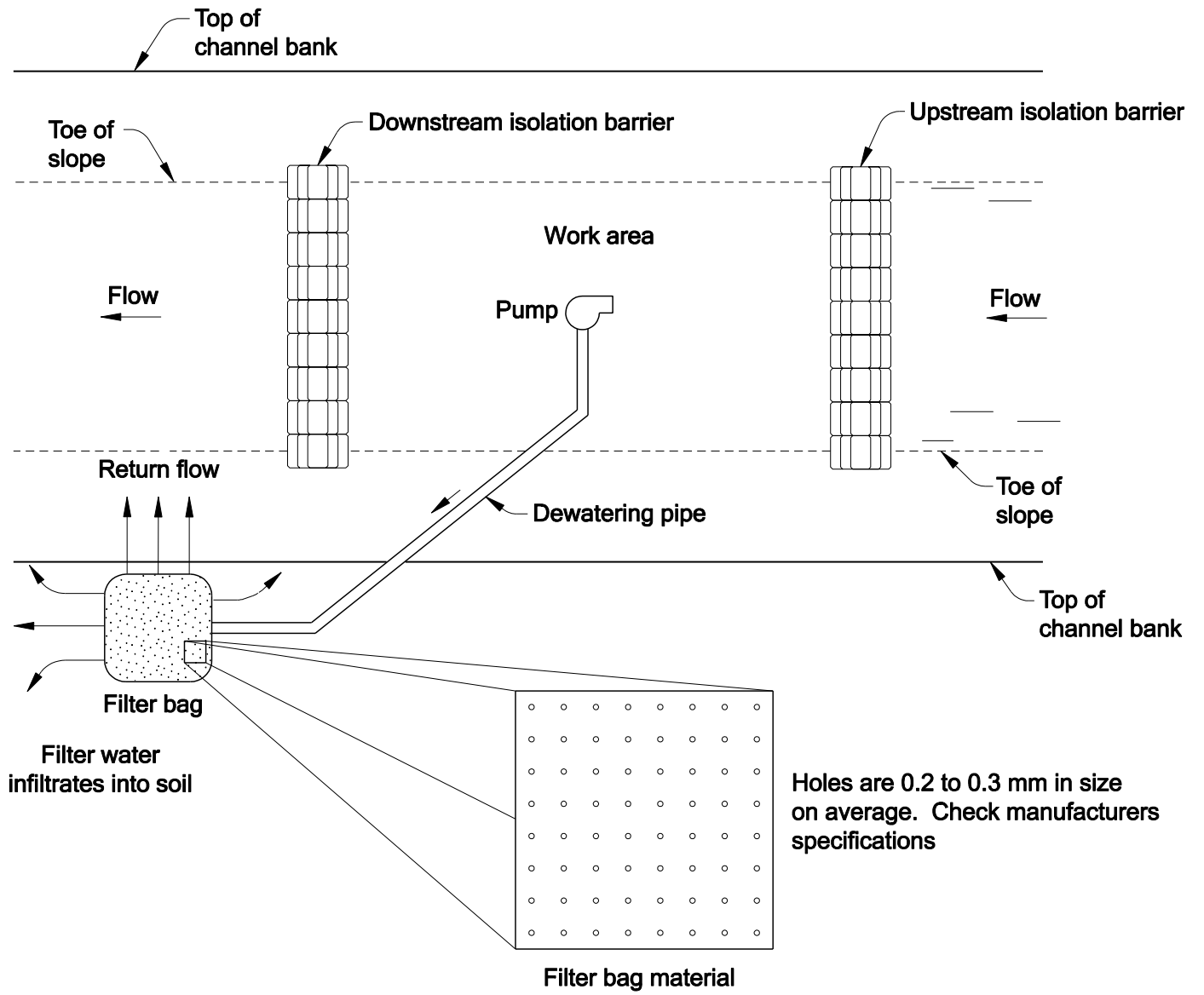


Figure 18-16 Filter Bag



Photo example of a Filter Bag

Implement into the concept plan utilizing a few common guidelines:

- Limit use to on the ground or on a trailer. The area needs to be stable and relatively level. Steep slope areas are not recommended as the bag may roll.
- Bags come in various sizes and recommended flow rates. Refer to manufacturer's literature for more detailed information.
- Bags can be connected to a 2, 3, 4, or 6 inch discharge hose

18.5.5.2 Rock Filter Berms

Rock filter berms utilize a mound of clean gravel that creates a settling chamber for the turbid water. A rock filter berm should be placed onto an impervious geotextile to discourage water from undermining the rock filter and to help contain the collected sediment. Rock filter berms are easy to install and are effective. This method is illustrated in Figures 16 and 17. Refer to ODOT's Erosion Control Manual for guidance.

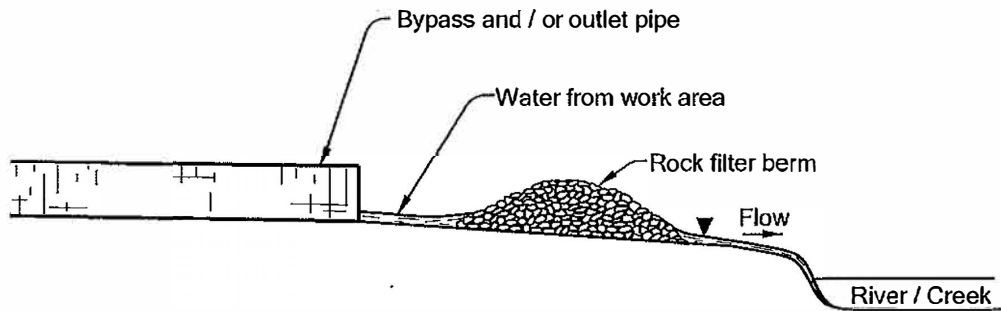
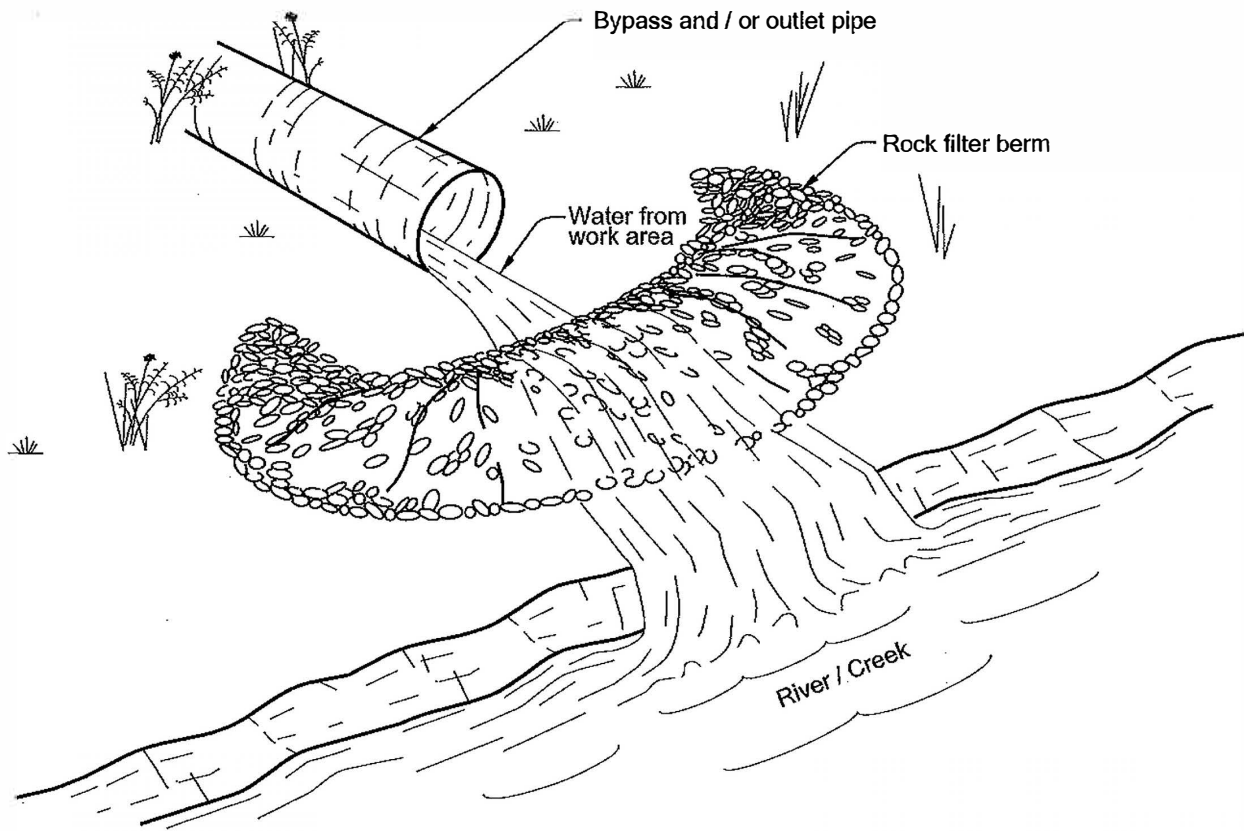


Figure 18-17 Rock Berm (channel bank installation)

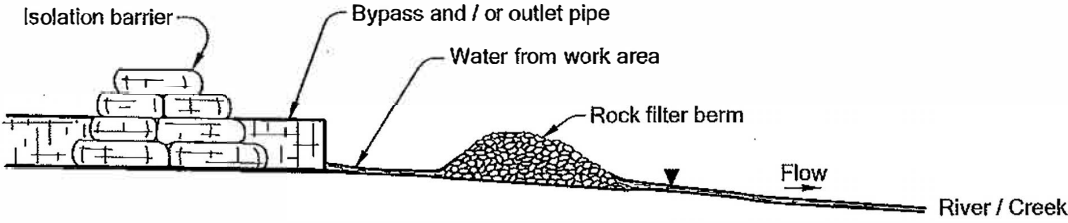
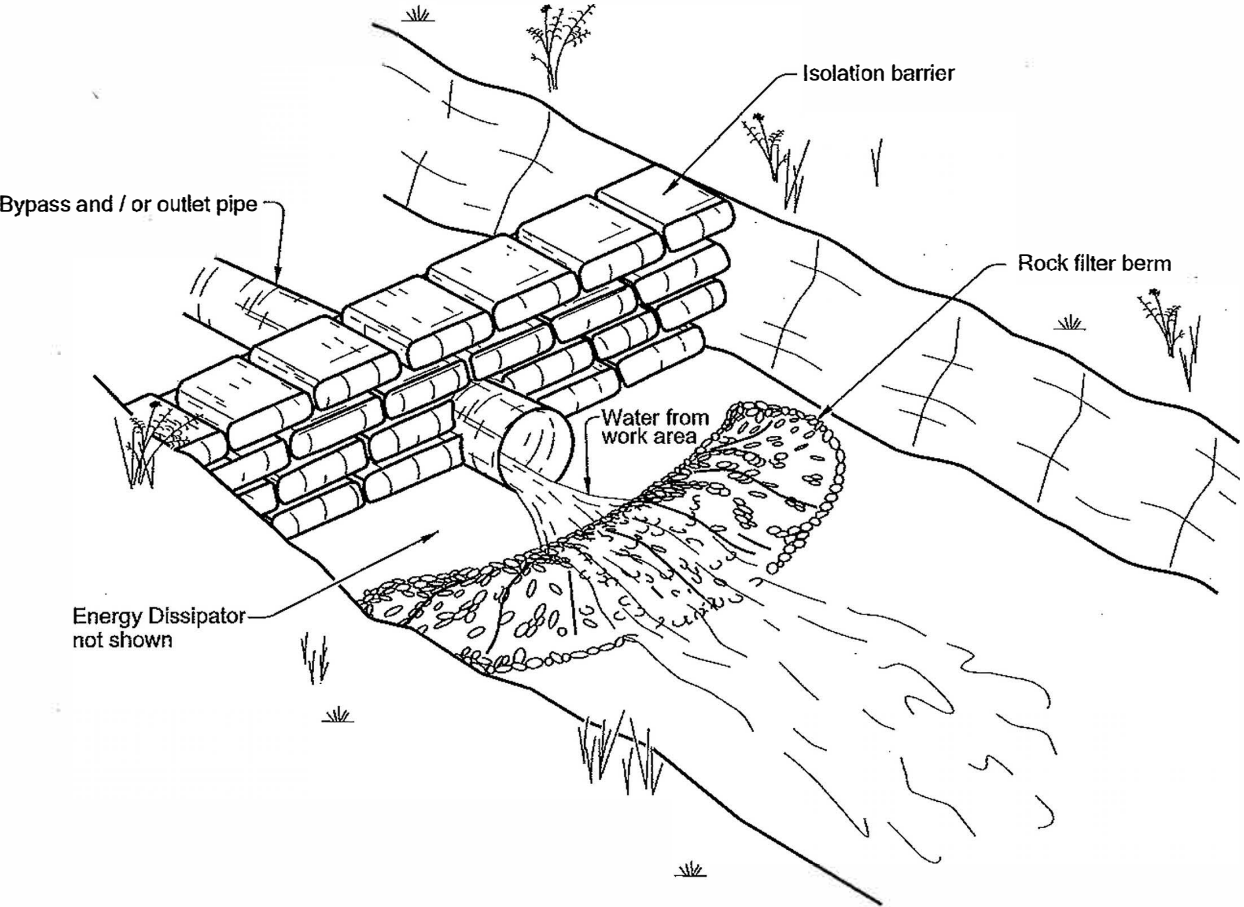


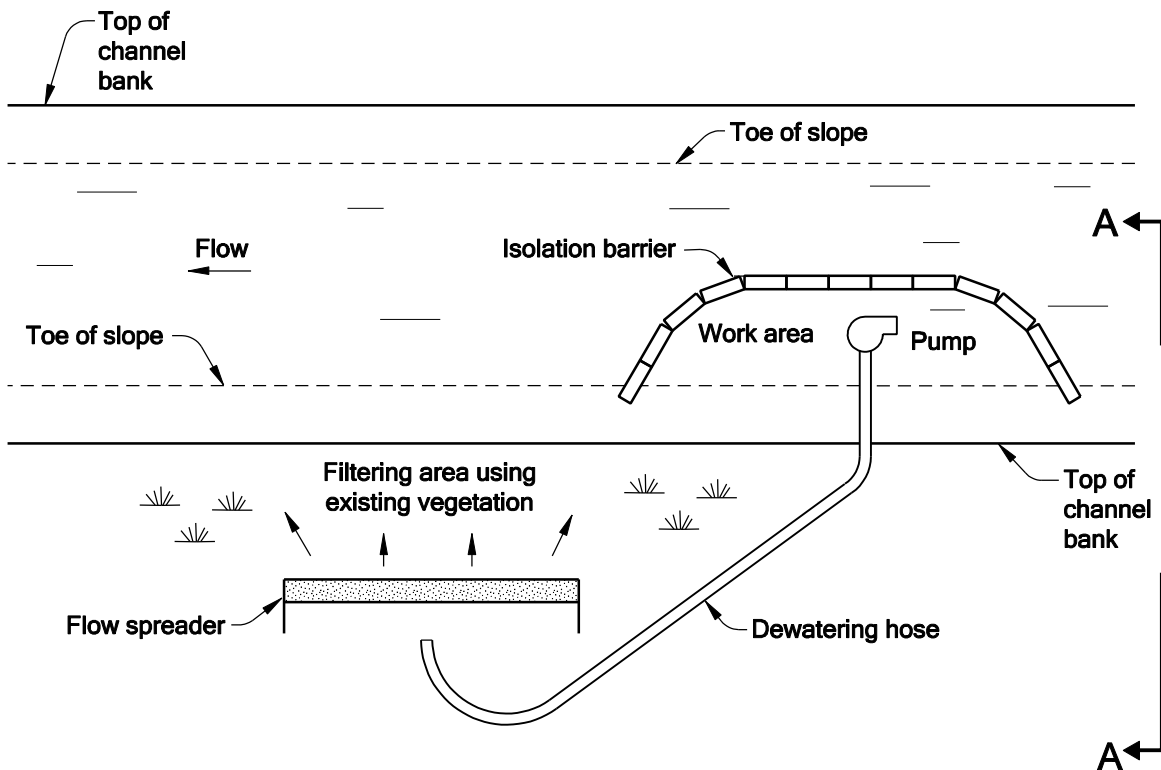
Figure 18-18 Rock Berm (channel installation)

18.5.5.3 Dispersion

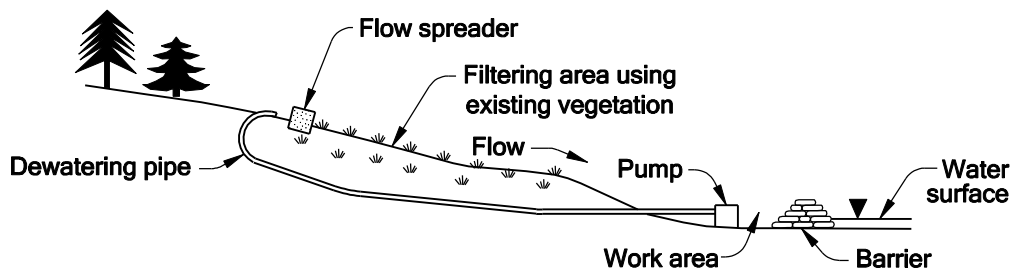
Mild sloped areas adjacent to the waterway can be used as a temporary dispersion spot to remove sediments from pumped water prior to draining back into the waterway. Concentrated flows from pumping may be dispersed with a flow spreader to achieve sheet flow conditions. Sheet flow across vegetated ground maximizes water contact with vegetation and results in optimal filtration performance. This method is illustrated in Figures 18 and 19.

Implement into the concept plan utilizing a few common guidelines:

- Vegetated areas along the project site or imported turf could be utilized to disperse pumped water. Imported turf should be anchored to prevent it from sliding down the side slope. The minimum surface area needed to accommodate this approach:
 - length: 6 feet or equal to flow spreader length; whichever is greater
 - width (flow width): 10 feet
- The maximum dispersion area slope: 33 percent
- Flow spreader: 6 foot minimum length

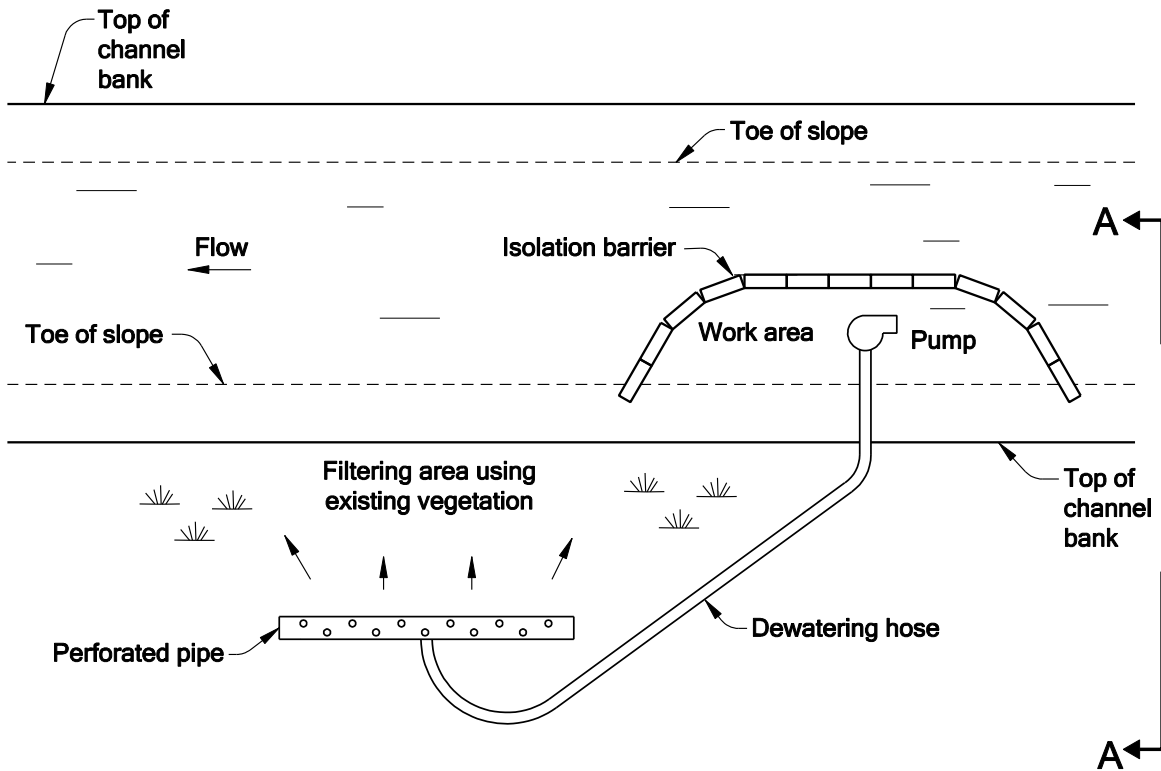


PLAN VIEW
NTS

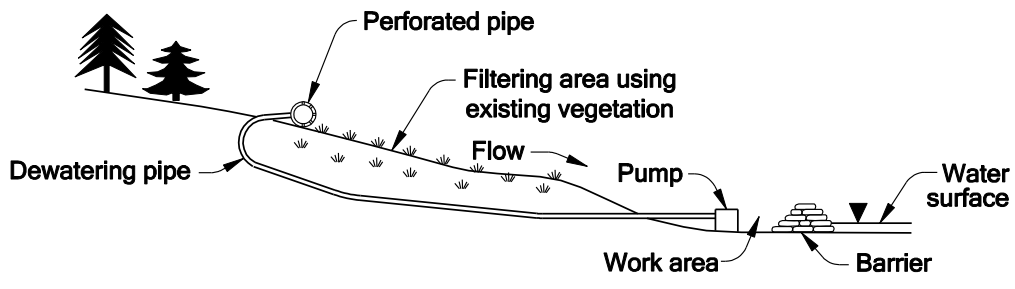


Section A-A
NTS

Figure 18-19 Dispersion using Filter Strip with rock berm flow spreader



PLAN VIEW
NTS



Section A-A
NTS

Figure 18-20 Dispersion using Filter Strip with perforated pipe flow spreader

18.5.5.4 Sediment Trap

TWM sediment traps are temporary ponding areas used to remove sediments through settling. Sediment traps can be constructed using sandbags and impervious liners, inflatable pool kits, an excavated hole with a liner or a portable truck or trailer mounted tank. The trap requires an outlet feature to convey the water back into the waterway channel. A sediment trap is illustrated in Figure 20.

Implement into the concept plan utilizing a few common guidelines:

- The surface area needed to accommodate a sediment trap:
Volume = (5%) (50 percent exceedance discharge) x 16 = cubic feet storage
Area = cubic feet storage /estimated storage depth.
- An outlet pipe from sediment trap to energy dissipator is necessary. Elevate invert of pipe above bottom of sediment trap to allow for detention time and sediment storage.
- An energy dissipator is necessary. Refer to Section 18.5.3



Photo example of Sediment Trap

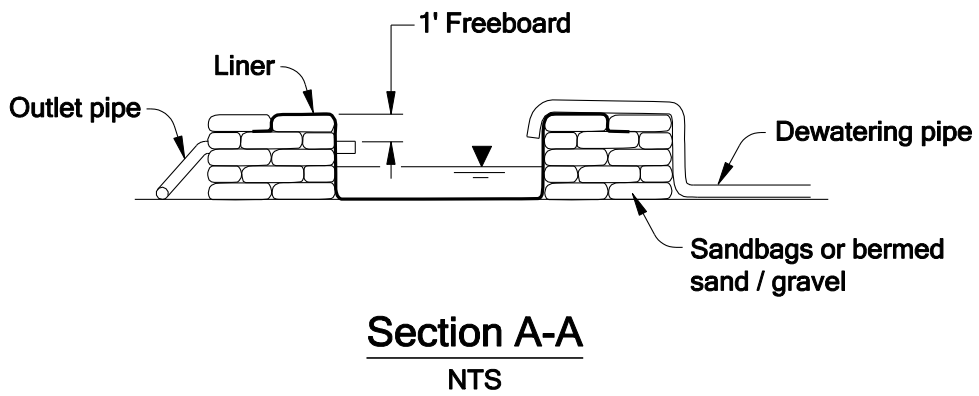
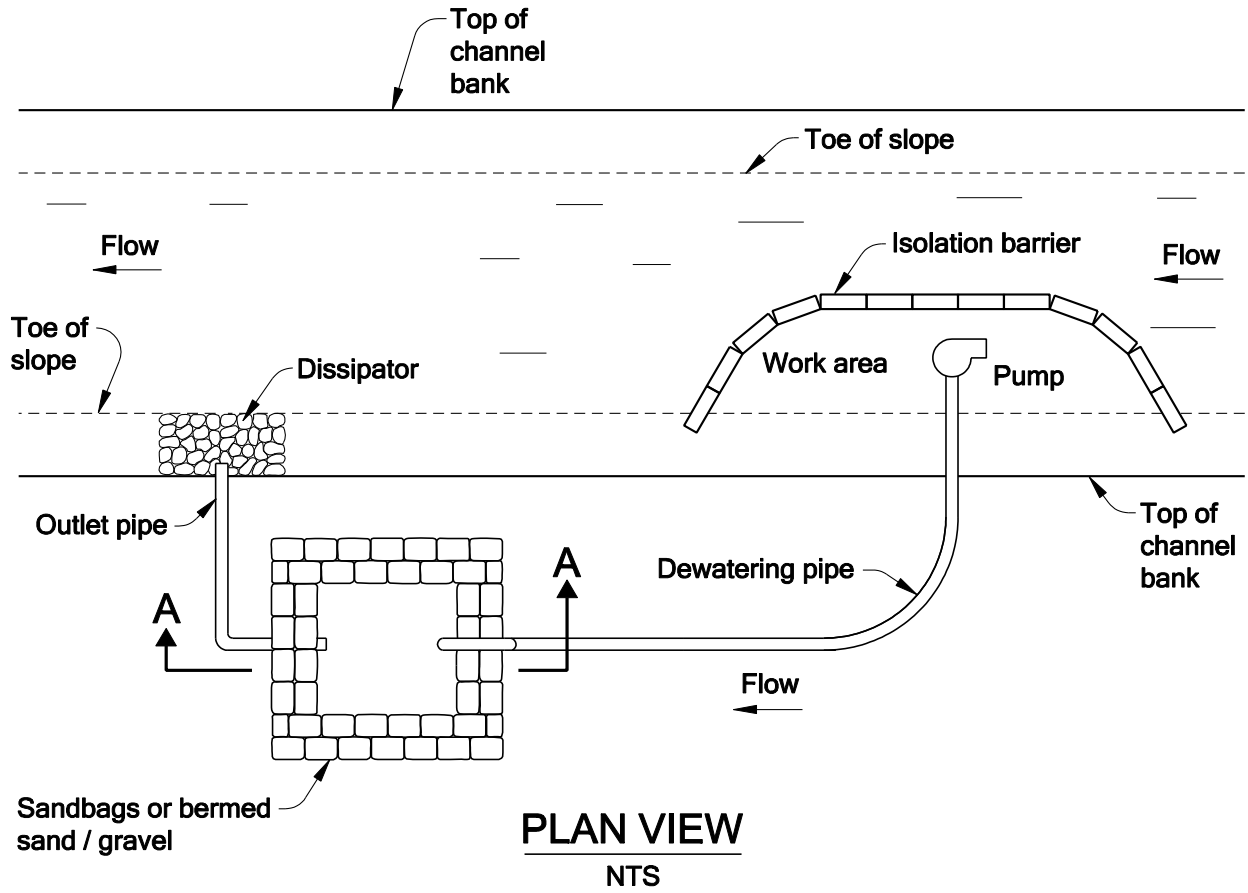


Figure 18-21 Sediment Trap

18.5.5.5 Swales

TWM swales are temporary constructed grass lined channels used to remove sediments by filtration through vegetation. A trapezoidal swale cross-section is illustrated in Figure 21. It is the ideal shape for temporary applications because the raised side slopes would help contain the flow along the grass channel and trap sediments.

Implement into the concept plan utilizing a few common guidelines:

- Utilize a temporary and mobile application such as constructing the trapezoidal channel using plywood and lining with sod. Other applications could be utilized as long as sheet flow conditions can be achieved for varying flow conditions. The **minimum** surface area needed to accommodate this approach (not including side slopes):
 - length (flow length): 25 feet
 - width: 4 feet
 - slope: 6 percent maximum
- Use in areas with mild slopes to promote slow velocities and increase retention time
- Use a flow spreader to reduce velocity of water exiting dewatering pipe before discharging onto swale

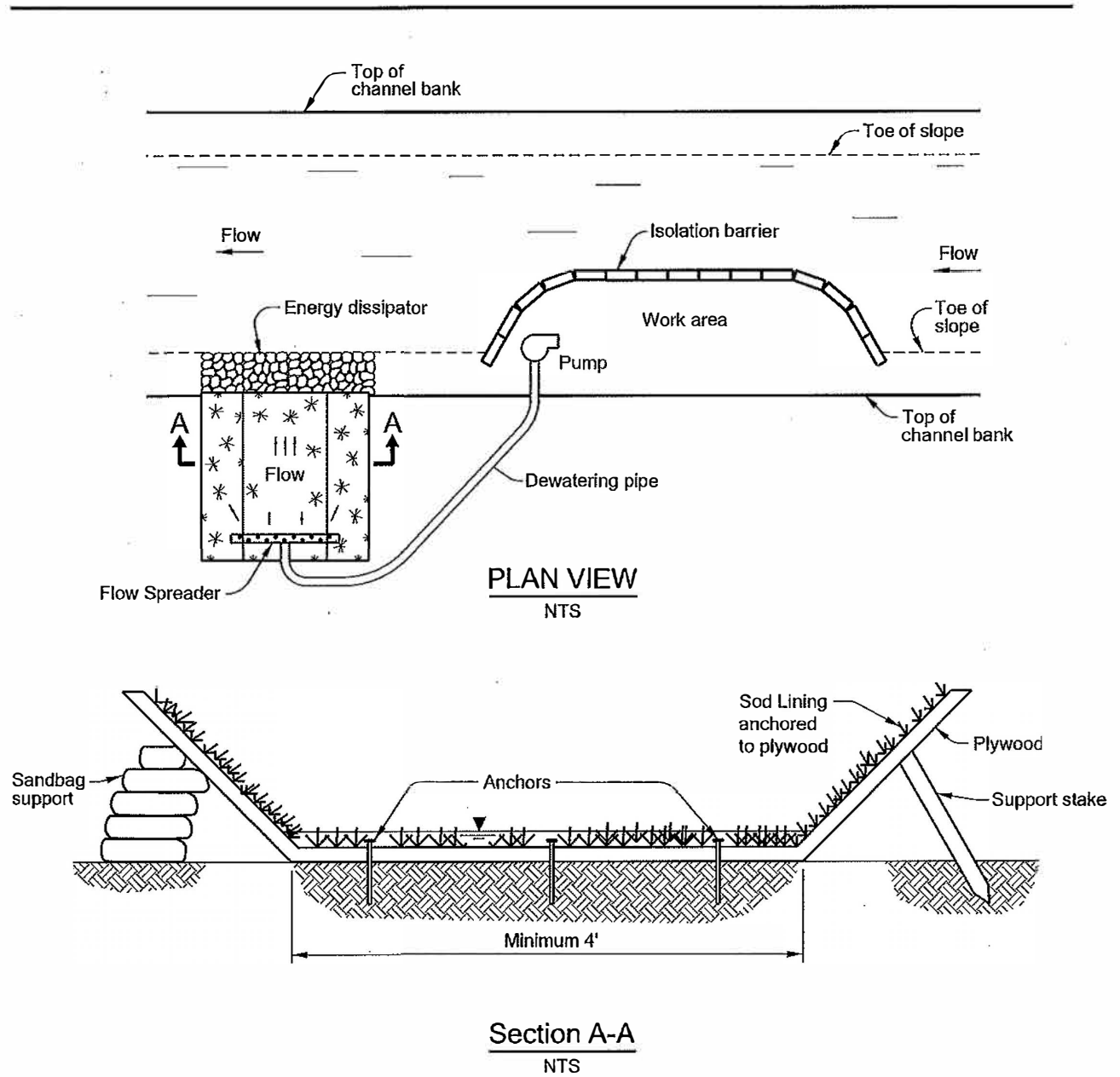


Figure 18-22 Swale

18.6 Design Procedure

The temporary water management concept design procedure involves many tasks. The typical concept design includes many, if not all, of the following tasks. Keep in mind:

- The goal is to prepare a TWM “Concept Plan” that is included with project plans and can be implemented based on site conditions. A stamped working drawing(s) is developed by the Contractor based on either the Agency’s concept plan or an independent plan.
- The concept plan should allow for construction or repair tasks to be accomplished under stable and safe conditions and minimize as much as possible environmental effects such as fish passage and disturbance of fish habitat, wetlands, and riparian areas.
- Redesigns can be minimized by coordinating the concept design of TWM with other project team members such as the biologist, environmental coordinator, permit specialist, project leader, and roadway designer early and throughout the development process.

Step 1 – Project task kick-off

Notify the project biologist, environmental coordinator, permit specialist, construction office, roadway designer, and bridge designer you will be the temporary water management designer on the project.

Step 2 – Determine Project Scope

- Determine and note the activities requiring temporary water management.
- Months of the year the temporary water management will be in place (usually the in-water work period)
- Requirements for temporary water management due to the chosen environmental permitting method. Coordinate with the project environmental coordinator or biologists.
- Available right-of-way
- Floodplain use regulations:
The Federal Emergency Management Agency (FEMA) regulations are discussed in Chapter 2, Chapter 3 and Chapter 6, Section 6.4.1. When work is to occur within a floodway, it is necessary to comply with applicable regulations and consult with the local FEMA coordinator to discuss the concept design and incorporate any issues that result from this effort.
- Water Right Issues:

The objective of using isolation methods along rivers and creeks is to allow for continuous flow through or around the work area. This is the most desirable approach because this should lessen habitat impacts. Quite often no additional permits are required when rerouting methods are used for the duration of the project.

Water rights to neighboring property owners should not be interrupted throughout the duration of the project. Storage, diversions or water uses are determined using Oregon Water Resources Department (OWRD) information. Identify nearby surface water withdrawal points using data available from OWRD. Visit the project site to verify the conditions that need to be maintained when surface water withdrawal points are in the immediate vicinity of the project. Care is needed during project temporary water management to allow for any surface water withdrawal points to operate for the duration of the project. There are two design options:

- (1) The preferred approach is to work around the withdrawal point(s) without having to temporarily relocate during construction activities, or
- (2) Temporarily relocate withdrawal point(s) during construction. Coordinate relocation and restoration of withdrawal point(s) and easements with project leader, property owner, and right-of-way specialist.

Locate these points and note applicable provisions to maintain access to water on the temporary water management plan. A description of water right issues should be included in the project hydraulics report.

The removal of all or a portion of flow from a river or creek is known as diversion. This approach may have significant biological impacts; affect the scope of hydraulic work and the total project costs. Coordinate with project environmental staff and regulatory agencies for site requirements when this option is being considered during temporary water management. Regulatory requirements and supporting narrative comments should be documented in the project hydraulics report.

- In-water work period: In-water work guidelines have been developed by ODFW to assist the public in minimizing potential impacts to important fish, wildlife and habitat resources. These guidelines apply to Oregon rivers, tributaries, associated reservoirs and lakes, bays, and saltwater estuaries.

The ideal TWM approach is to prepare the concept plan assuming the work will be implemented during the in-water work period. The in-water work period can be determined by going to ODFW's website, (<http://www.dfw.state.or.us/lands/inwater/>), or asking the project biologist.

- **Fish Passage:** Fish passage is the ability for fish to travel freely up and down the waterway they occupy.

Maintaining upstream and/or downstream fish passage during the time the temporary water management structure will be in place is a concern to regulators and may be a permit requirement for any given project. Therefore, this is a very important issue and must be considered, evaluated, and coordinated with the project team on all projects that require temporary water management.

Note:

- It is common not to have any fish passage concerns during partial isolation and working in the wet installations because water is allowed to continue flowing downstream through the non-isolated channel without any significant changes in water depth and velocity.
- Fish passage cannot be provided during a full isolation installation using pumps to route streamflow around the work area.
- Fish passage through a bypass pipe depends on diameter/span, slope, and flow conditions which will vary throughout the duration of a project. Downstream passage during any flow condition is not difficult to accommodate because fish traveling downstream would be moving in the direction of flow. Upstream fish passage is limited to when flow conditions are reasonable for fish to make the journey through the pipe. The slope, diameter/span and length of the bypass pipe will impact velocity conditions due to confining the flow from the stream channel to a pipe barrel.

Step 3 – Determine Hydrology

Temporary water management designs require discharge estimates for a portion of the year when construction will take place. These discharges are used to estimate the need for isolation barriers, bypass piping and/or pumps, energy dissipators, dewatering pumps, and sediment control features as outlined in the concept plan. Then the design of these features would be based on the actual flows observed on the jobsite by the Contractor's Engineer preparing a working drawing based on the ODOT prepared concept plan or an independent plan that meets water quality and environmental requirements, and does not affect neighboring properties and water rights.

Mean daily exceedance discharges are used in temporary water management. Exceedance discharges are estimated surface water discharges throughout the construction period and are used in temporary water management design. The exceedance discharge is the mean daily discharge that is expected to be exceeded for a specified number of days during the subject month. Usually this is expressed as a percentage of the days in the month. The discharges most often used are the 5, 10, 25, 50, and 95 percent exceedances.

General steps to determine hydrology include:

- determine the months of the year temporary water management will be in place (usually the in-water work period established by Oregon Department of Fish and Wildlife). See Chapter 3 for additional guidance on installations used within and outside of the flood season.
- follow the steps outlined in **Chapter 7**, Appendix J to estimate exceedance discharges for the months TWM will be in place or utilize the USGS software program named National Streamflow Statistics (NSS). The NSS program is not part of ODOT's Hydraulics overlay. It would need to be installed onto your computer by contacting the Computer Support Desk. Others can download this software from the following website: <http://water.usgs.gov/software/NSS/>

Note: A cooperative study between the USGS and the Oregon Department of Transportation resulted in developing methods for calculating flow duration quantiles for the 5, 10, 25, 50, and 95 percent exceedances from streamflow records and developed regression equations that relate basin physical and climatic characteristics to flow statistics. These equations provide estimates of unregulated flow conditions at locations where streamflow data are unavailable (ungaged sites). This data has been incorporated into the NSS program. The study can be viewed at the following website: <http://pubs.usgs.gov/sir/2008/5126/>

- determine the maximum predicted discharge when necessary. This discharge would be necessary for critical facilities such as coffer dams, bypass pipes or temporary bridges on critical roadways, or work bridges. Follow the steps outline in **Chapter 7**, Appendix K to estimate the maximum predicted discharge.
- use the calculated exceedance and maximum predicted discharges to prepare the discharge table in the hydraulics report and concept plan. Example of a discharge table included in the hydraulics report is provided below. Example of a discharge table included in a TWM concept plan is provided in Figure 23.

Note:

The objective of temporary water management is to provide for uninterrupted streamflow through the project site and it is almost always required by the permitting regulatory agencies. This continuous flow prevents the downstream channel from drying up and killing aquatic life and may require fish passage upstream, downstream, or both. Coordinate with project environmental staff and regulatory agencies for site requirements.

Discharges less than or equal to 0.5 cubic feet per second (224 gpm) are almost a trickle in most streams and can be difficult to convey with gravity flow systems. The streamflow sometimes percolates under the barriers and flow through the bypass pipe ceases or is reduced to a trickle. Often the solution to manage upstream flows less than 0.5 cubic feet per second is to pump the water through the worksite. The pump must be small enough to operate continuously and deliver an uninterrupted flow.

Discharges greater than 0.5 cubic feet per second (224 gpm) are often impractical to pump through the work site because multiple portable pumps or a single trailer mounted pump would be required. Gravity flow systems or other methods would be used to manage upstream flows greater than 0.5 cubic feet per second. The gravity system would be sized to convey water during the wettest construction month. Quite often it is possible to use a combined system: pumping during work hours and gravity flow during off hours.

DRY CREEK AT HWY 99W
ESTIMATED DISCHARGES FOR
TEMPORARY WATER MANAGEMENT

	AVERAGE DAILY DISCHARGE IN CUBIC FEET PER SECOND (GALLONS PER MINUTE)		
NOTE	1	2	3
JULY	3.1 (1,400)	2.0 (900)	1.4 (630)
AUGUST	2.0 (900)	1.1 (490)	0.77 (350)
SEPTEMBER	2.5 (1,100)	1.3 (580)	0.68 (310)
OCTOBER	11.0 (5,000)	3.3 (1,500)	1.4 (630)

- 1) Average Exceedance Discharge (Average daily discharge expected to be exceeded 2 days each month.)
- 2) Average Exceedance Discharge (Average daily discharge expected to be exceeded 8 days each month.)
- 3) Average Exceedance Discharge (Average daily discharge expected to be exceeded 16 days each month)

In-Water work period extends from 1 July through 15 October

Listed discharges are surface water from the upstream watershed. The estimated discharges are based on nearby gaged basins. Discharges in the subject watershed may differ.

TWM Discharge Table included in Hydraulics Report and concept plan

Step 4 – Visit the project site

- Take Photos. At a minimum, photos should be taken of:
 - highway, looking toward increasing milepoint
 - highway, looking toward decreasing milepoint
 - scour or erosion problems when a stabilization or repair task
 - upstream and downstream of crossing structure when applicable
 - possible areas to place sediment control features

- Prepare a photo log and include in the project design file
- Verify Hydrology calculations are reasonable. It is important to remember that the calculated discharges are for flows for an average year and are almost always based on gage records on nearby streams. This prediction method cannot predict discharges during the TWM period with absolute certainty. Therefore, the TWM design should have some flexibility to handle unexpected discharges.
- Document site characteristics such as:
 - Debris concerns
 - Cross-sections and approximate bank slopes
 - Neighboring structures
 - Any nearby water withdrawal features
 - Ground cover conditions (e.g. trees, boulders, erosion)
 - Channel stability concerns
 - Approximate bed material size and gradation
 - Utilities within project boundaries

Step 5 – Coordinate additional data (as needed)

Assemble additional data such as streambed profiles, channel and overbank area cross-sections, OHW elevation mark elevation, existing structures, utilities, etc. as discussed in Chapter 6.

Step 6 – Verify survey

The type, source, and complexity of data for a temporary water management design will vary depending on the location and type of construction activity. It is important to verify accuracy and completeness at this stage of the design process.

Step 7 – Determine the isolation approach

There are almost always several alternatives that could be implemented at any given project site. Select what appears to be the best option. Discussion on the isolation approaches and components are discussed in Sections 18.4 and 18.5.

Step 8 – Develop a TWM Concept Plan

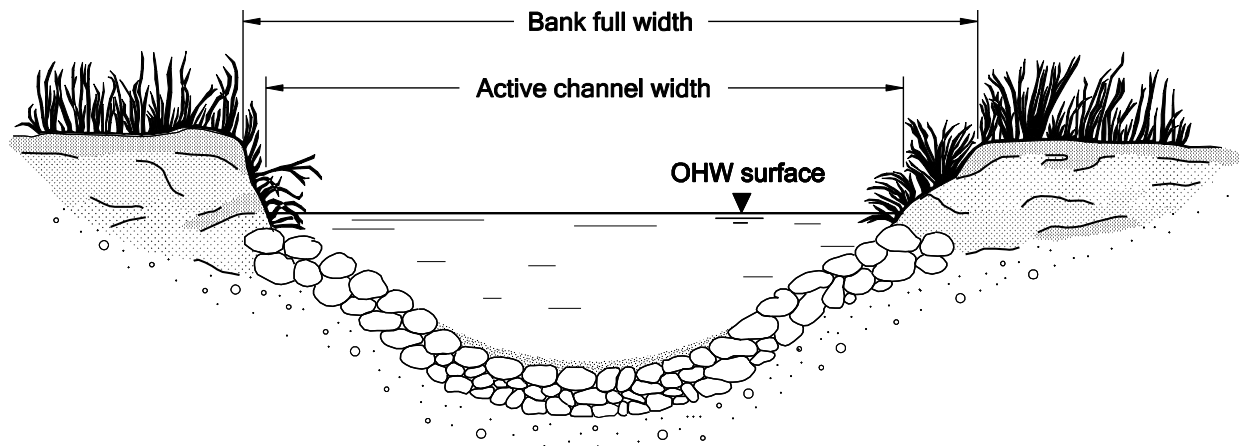
Develop a temporary water management concept plan. This plan will be included with the final design plans. Distribute for review and comment as noted in the design step below.

- Note on the plan the selected option to control water during construction.

- Include any constraints on plan such as highway and road locations, right-of-way boundaries, existing structures, utilities, etc.
- Include ordinary high water mark (OHW) to establish the regulated work area (See Chapter 6). Work within the regulated work area is allowed only during the in-water work period. The Hydraulic Engineer and Biologist field locate the ordinary high water marks. The active channel width is determined by the distance between the ordinary high water marks. The requirements for field assessment, flagging, and documentation of the ordinary high water mark are outlined in ODOT Geo-Environmental Technical Bulletin GE09-07(B). A link to this bulletin is provided below:

http://www.oregon.gov/ODOT/HWY/TECHSERV/docs/tech_bulletins/GE09-07b.pdf

- Typical temporary water management components included on plan:
 - Limits of isolation (see step 10)
 - Construction limits (see step 10)
 - Isolation barriers (see Chapter section 18.5.1)
 - Bypass pipe or other bypass features when applicable (see Chapter section 18.5.2)
 - Pumps when applicable (see Chapter section 18.5.2).
 - Pump screening detail and notes when applicable - incorporated into the standard templates (see template examples below)
 - Energy dissipater (see Chapter section 18.5.3)
 - Sediment control facility (see section 18.5.4)
 - Temporary water management discharge table. Add hydrology data according to Step 3.
 - Specific notes
 - Temporary construction easements



Active channel width and bankfull width

Step 8a – Coordinate TWM Concept Plan Drafting

A template is available for preparing partial or full-isolation concept plan sheets. The name of the template file is Seed_TWM.dgn and is located with other seed files in ODOT's MicroStation workspace. The file contains a ready-made plan sheet (or template). The template contains instruction on use and includes general notes, details, a fillable discharge table, and an area for laying out the TWM concept plan.

Step 9 – Distribute the TWM plan for review and comment

Distribute the plan to the project team and project manager's office. Modify concept design as needed based on review comments.

Then meet with environmental and permitting staff and review the proposed concept plan. Verify the concept plan can obtain a permit. It is necessary to work out permitting issues at this early stage of design.

Be prepared to repeat this step more than once.

Step 10 – Verify there is adequate right-of-way for temporary water management

No temporary construction easements are necessary if adequate right-of-way is available. If adequate right-of-way is not available, coordinate temporary construction easements with the project leader and right-of-way agent.

A project's temporary water management construction limits is the area or boundary needed to accommodate project isolation features (such as barriers, bypass piping, pumps and hoses, fish isolation netting, and sediment control measure), construction materials, equipment, mobility, and other activities. The construction limits should be estimated early and accurately during the design process to allow adequate time to negotiate and purchase project construction easement(s) when applicable and may be referenced in project environmental documents.

The following procedure outlines the typical steps in estimating temporary water management construction limits and coordinating construction easements when necessary.

- Estimate the limits of isolation.

The construction limit for temporary water management is determined by the hydraulics designer by first estimating the limits of isolation. Limits of isolation marks the area needed to perform the work within the waterway. All three isolation method limits are marked with the barriers used to isolate the work area. For example, a full isolation project would place a barrier upstream and downstream of the work area. The limits of isolation would be the distance between these barriers. The limits of isolation for partial isolation and working in the wet would be from waterway bank to the isolation barrier.

- Estimate the TWM construction limits.

The TWM construction limit would then be estimated beyond the isolation limits to allow for adequate area for mobility and construction activities.

Always try to minimize the TWM construction limits. This is recommended and desirable because this approach should lessen habitat impacts. This is important because it is typically the number one priority of regulators. Also, this may ensure a shorter review from regulators if the isolation plan demonstrates impacts are minimized to only what is needed to perform the work.

- Submit construction limits to the project roadway designer.

The estimated construction limits for temporary water management is submitted to the roadway designer for consideration of the overall project construction limit. Construction limits for other highway features would also be submitted by other project team designers to the roadway designer for consideration of the overall project construction limit. The construction activity requiring the greatest area would establish the construction limits for the project. Any project construction limit area needed beyond the highway right-of-way would require construction easements. The roadway designer most often coordinates all project construction easements with the right-of-way specialist.

Note:

- A Construction easement is an agreement between ODOT and a neighboring property owner(s) that allows access to the construction site through private property to perform temporary construction activities on private property such as staging of equipment, stock piling of materials, temporary water management or other temporary construction activities when applicable.
- All permanent highway facility features should be limited to within the regulated waterways or highway right-of-way unless permanent easement(s) or additional right-of-way has been purchased as needed from neighboring property owners.

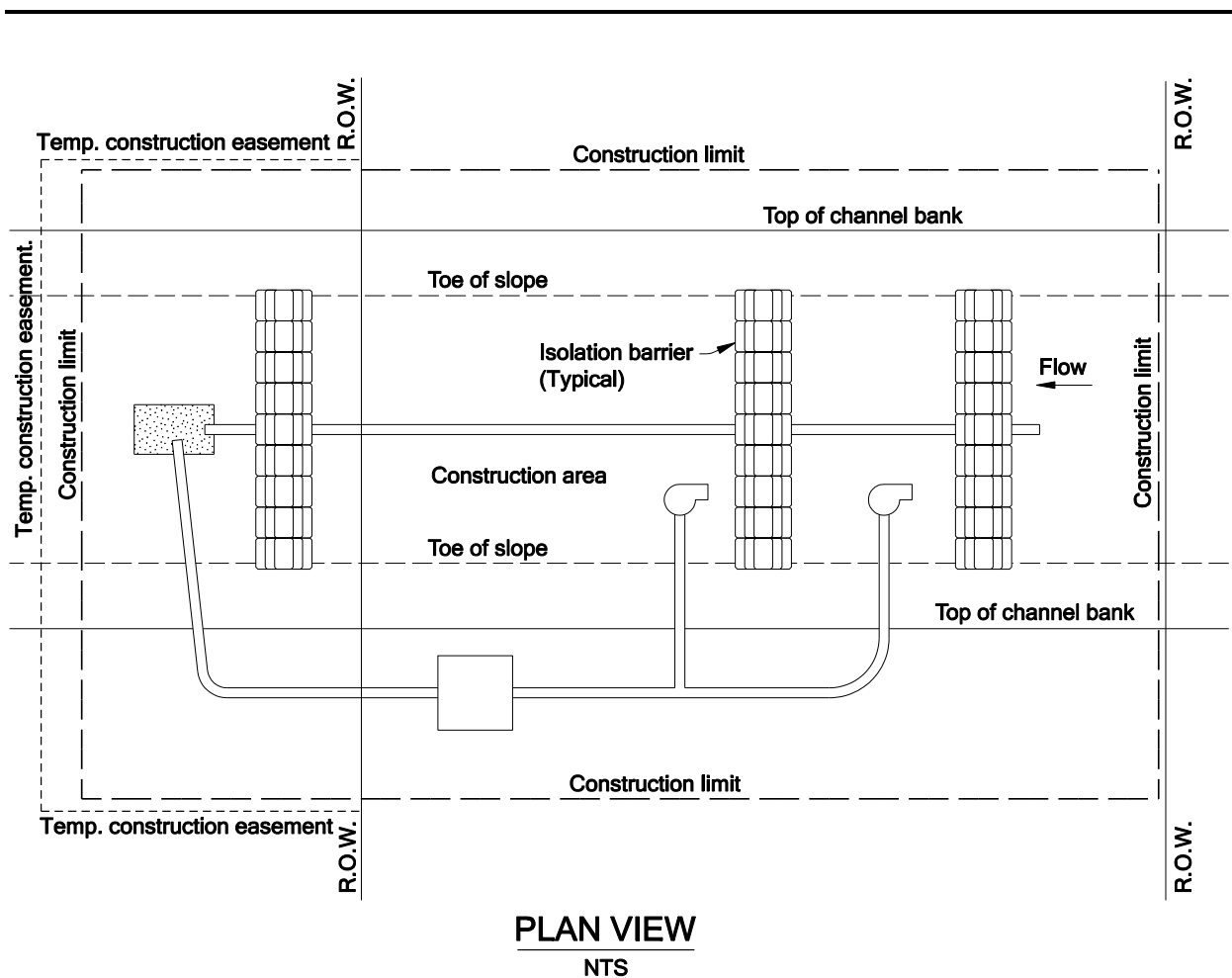


Figure 18-23 Example Temporary Construction Limits and Extent of Work Area Isolation

Step 11 – Preliminary Plans (or DAP) review comments

Distribute the concept plan to project team designers, project manager's office, environmental staff and project permit specialist. Comments from the project team, regulators and other interested parties are used to prepare the detailed hydraulic recommendations and revise the temporary water management plan.

Step 12 – Prepare TWM section of the Hydraulics report

Prepare recommendations for temporary water management and include in the project hydraulics report according to Chapter 4.

Step 13 – Advanced plans review comments

When applicable, revise and submit temporary water management concept plan.

Step 14 – TWM plan and Permit Coordination

Coordinate with environmental staff and project permit specialist to verify permit is consistent with temporary water management plan. Changes to permit or plans are usually required to bring these documents into agreement.

Step 15 – Plans-in-hand review comments

Collect comments from plans-in-hand meeting. Revise plan as necessary. Submit plan with final design plans. Figure 22 is an example of a TWM plan “concept only”.

Step 16 – Prepare Special Provision

Utilize Special Provision SP00245. This provision can be viewed and downloaded at the following website:

http://www.oregon.gov/ODOT/HWY/SPECS/Pages/2008_special_provisions.aspx#Part_00200

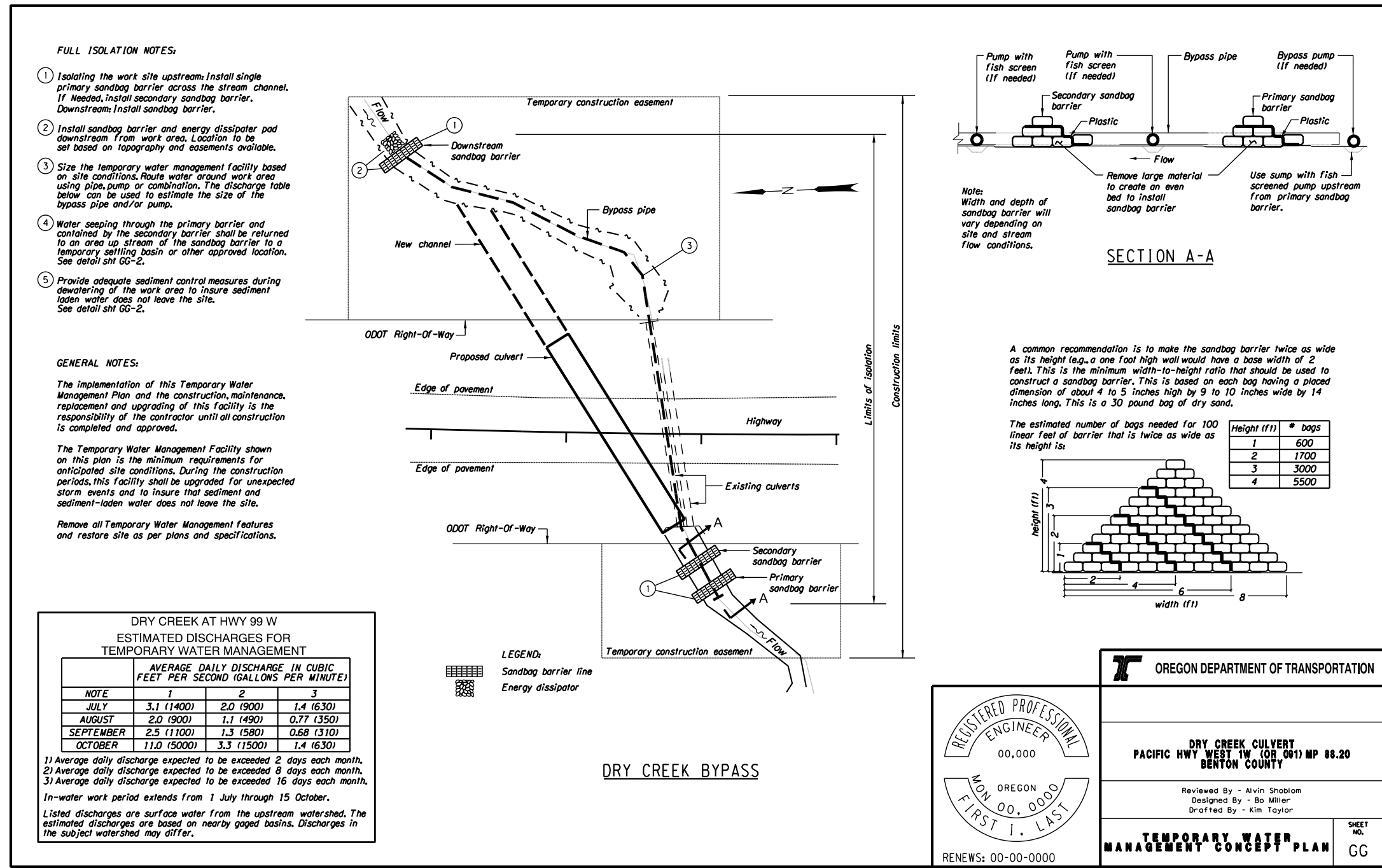


Figure 18-24 Example Drawing of a TWM Concept Plan (Full Isolation)

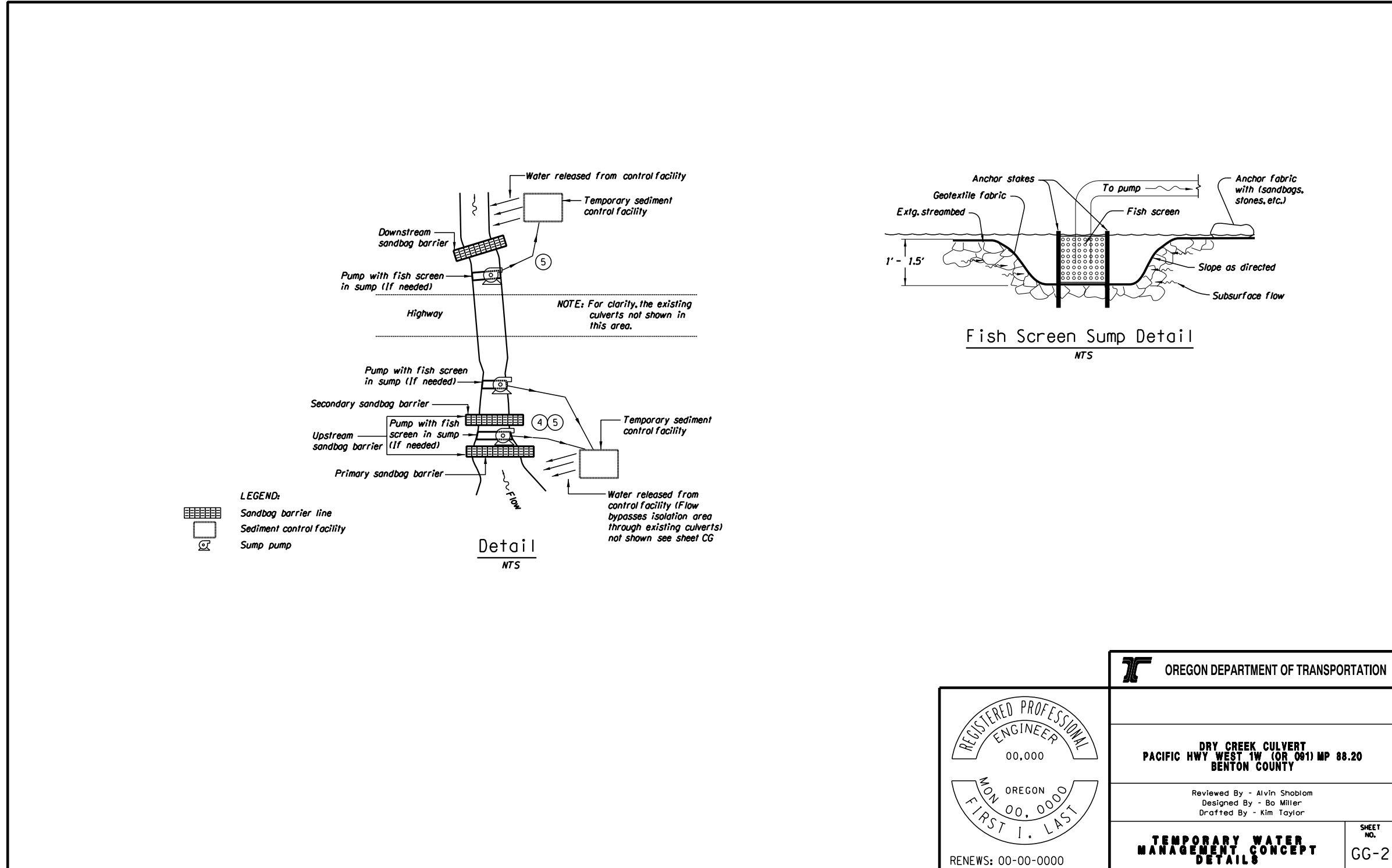


Figure 18-25 Example Drawing of a TWM Concept Plan (Full Isolation Page 2)

	OREGON DEPARTMENT OF TRANSPORTATION	
	DRY CREEK CULVERT PACIFIC HWY WEST 1W (OR 001) MP 88.20 BENTON COUNTY	
	Reviewed By - Alvin Shoblom Designed By - Bo Miller Drafted By - Kim Taylor	
TEMPORARY WATER MANAGEMENT CONCEPT DETAILS		SHEET NO. GG-2

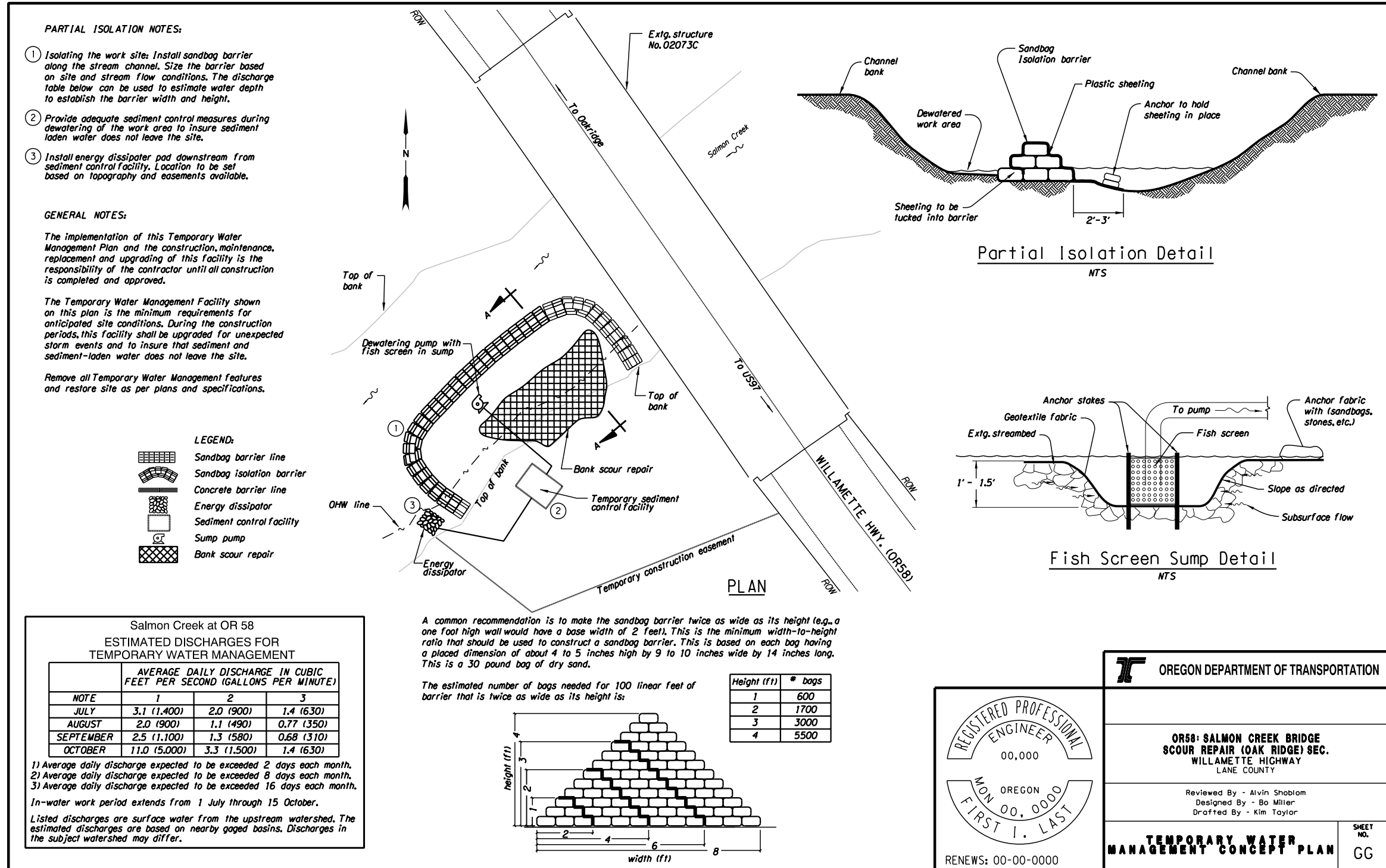


Figure 18-26 Example Drawing of a TWM Concept Plan (Partial Isolation)

This page intentionally left blank

Benton County BMP Document

2022

APPENDIX I

When is a Permit Required?

Oregon Department of State Lands (2019)

7.1. When Is A Waterway (Corps/DSL) Permit Needed for Ditch Maintenance?

Answer all questions from both columns

WATERWAY ISSUES		WETLAND ISSUES
Is there running or standing water in drainage facility other than during or after rainfall events?	Yes <input type="checkbox"/> <input type="checkbox"/> Yes No <input type="checkbox"/> <input type="checkbox"/> No	Is there wetland vegetation (willows, rushes, cattails) in ditch?
Does the drainage have an open water connection to a lake, pond, creek, river, or wetland?*	Yes <input type="checkbox"/> <input type="checkbox"/> Yes No <input type="checkbox"/> <input type="checkbox"/> No	Is there standing water or wetland vegetation adjacent to ODOT ROW? (Call Region Environmental Coordinator for assistance)
* If yes, contact REC to make appropriate coordination with local ODFW/NMFS fisheries biologist regarding potential impacts to fish.		
Is the waterway subject to tidal influence?	Yes <input type="checkbox"/> <input type="checkbox"/> Yes No <input type="checkbox"/> <input type="checkbox"/> No	Would the activity add to or change the existing facility? (Add rip-rap, extend culverts, ditch widening or deepening or new work)

A 'Yes' to any questions in this column

If ALL responses are 'No'

A 'Yes' to any question in this column

PERMIT AND BIOLOGICAL ASSESSMENT MAY BE NEEDED

Contact Region Environmental Coordinators

NO WATERWAY PERMITS NEEDED

If ODOT Best Management Practices are followed

PERMIT MAY BE NEEDED

Contact Region Environmental Coordinators

ODOT Environmental Permit Coordinators: Check regional listings for name and phone number.

Chapter 2: When is a Permit Required? – *At a Glance*

Oregon’s Removal-Fill Law (ORS 196.795-990) requires any person who plans to “remove or fill” material within “waters of this state” to obtain a permit from the DSL. There is one exception, permitting on the beach between lowest measured tide and the vegetation line is administered by Oregon Parks and Recreation Department.

[Waters of this State: Types of Jurisdictional Waters and their Boundaries](#)

Type of “Water of the State”	Jurisdictional Limit
Pacific Ocean	Extreme low tide to 3 miles out
Tidal Bays, Tidal Rivers, and Estuaries	Highest Measured Tide (HMT) or upper edge of wetland
Rivers, Perennial Streams, Lakes and Ponds	Ordinary High Water (OHW)
Intermittent Streams	OHW
Wetlands	Wetland boundary
Artificially Created Ponds and Ditches	OHW
Artificially Created Wetlands	Wetland boundary
Reservoirs	Normal operating pool level or upper edge of adjacent wetland

Highest Measured Tide (HMT) is determined by using tidal station data, installing a tidal gage on site, or by using field indicators. Ordinary High Water (OHW) is determined by direct observation of an annual event, gauge data or field indicators. The wetland delineation method adopted by the Corps is used to determine wetland boundaries.

[Definition of Removal and Fill](#)

Removal means taking inorganic substances (rock, gravel, sand, silt, etc.) and large woody debris; or their movement by artificial means within waters of this state, including channel relocation. Fill means the deposit by artificial means of any material (organic or inorganic) at any one location.

Large Woody Debris is defined as any naturally downed wood that captures gravel, provides stream stability or provides fish habitat, or any wood placed into waters of this state as part of a habitat improvement or conservation project.

[Removal-Fill Volume Thresholds](#)

For many waters of this state, a permit is required if a project will involve 50 cubic yards of fill and/or removal (cumulative) within the jurisdictional boundary. For activities in ESH streams, State Scenic Waterways and compensatory mitigation sites, a permit is required for any amount of removal or fill. Removal is calculated on an annual basis. Fill is calculated on a cumulative basis.

[Calculating Removal-fill Volumes](#)

Guidance and examples for calculating removal-fill volumes is provided.

[Special Situations: Activities that Cannot Be Permitted By Law or Rule](#)

Exploration for minerals within the territorial sea and navigable bays is prohibited by statute.

Chapter 2: When is a Permit Required?

Oregon's Removal-Fill Law (ORS 196.795-990) requires any person who plans to "remove or fill" material in "waters of this state" to obtain a permit from DSL. As noted below, the one exception is that permitting on the beach is administered by Oregon Parks and Recreation Department. In determining whether a permit is required for a proposed activity, DSL must determine all of the following:

- The activity is proposed in a water of the state (i.e. a jurisdictional waterway or wetland)
- The activity meets the definition of removal or fill
- The activity is not exempt

Waters of This State - Types of Jurisdictional Waters and Their Boundaries

Waters of this state include the jurisdictional portions of the Pacific Ocean, tidal bays, tidal rivers, estuaries, non-tidal rivers, perennial and intermittent streams, lakes, ponds, wetlands, and reservoirs. In addition, certain ditches and created wetlands and ponds are also considered waters of this state. This section outlines the different types of waters of this state and provides guidance on what portion of those waters are jurisdictional.

The Pacific Ocean

DSL regulates removal-fill activities between extreme low-tide elevation seaward to the limits of the territorial sea, which is 3 statutory miles into the Pacific Ocean. Note this does not include the beach, which is defined as the area between extreme low tide (lowest estimated tide) and the "line of statutory vegetation" or "actual vegetation line" whichever is further inland (Figure 2-1). OPRD regulates earthwork on the beach through the [Ocean Shore Permit Program](#).

The Legislature charged DSL with determining "**waters of this state**" and their boundaries to implement the Removal-Fill Law. This is done through a formal jurisdictional determination. Since only DSL has the authority to make jurisdictional determinations, it is important to get concurrence from the Department prior to starting any work in waterways or wetlands.

The statutory vegetation line is the line described according to the Oregon Coordinate System and set forth in ORS 390.770. The line consists of a series of connected line segments. The "actual vegetation line" means the extreme seaward boundary of natural, non-aquatic vegetation. It is a visible boundary, marking the border between the dry sand beach and the adjoining upland. Seasonal occurrences or isolated patches of vegetation may lie seaward of the actual vegetation line.

The extreme low tide elevation is the lowest estimated tide that can occur in a given year. This line can change from year to year and does not have a fixed elevation. For this reason, it is best to contact a Jurisdictional Coordinator or an Aquatic Resource Coordinator to determine the elevation of extreme low tide for a specific project.

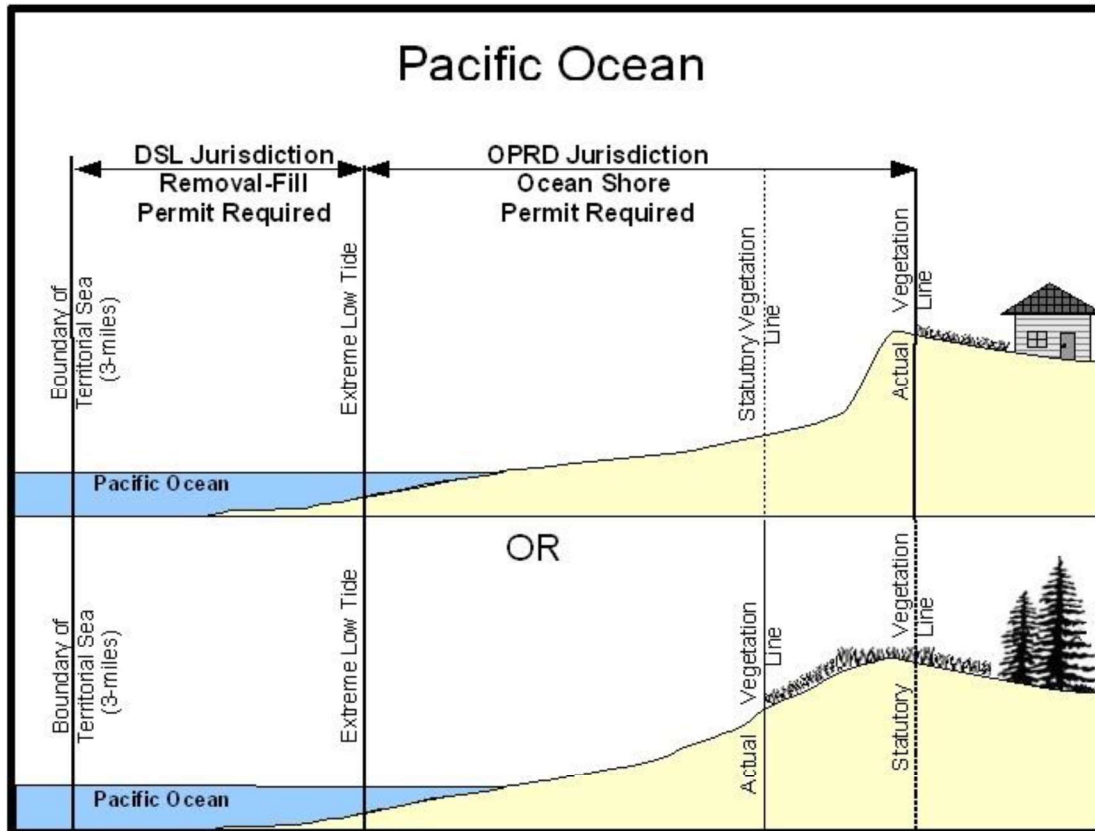


Figure 2-1: Jurisdiction of the Pacific Ocean and the beach (between extreme low tide and upland).

Tidal Bays, Tidal Rivers, and Estuaries

A waterway is considered tidal if it is located below the head of tide. The head of tide is the farthest point upstream where a waterway is affected by tidal fluctuations. The head of tide is established for coastal rivers and streams and maps are located in the publication, *Heads of Tide for Coastal Streams in Oregon*. Although the Columbia River's actual head of tide is located at Bonneville Dam, 146 river miles upstream from its mouth, the western edge of Puget Island around River Mile 38 has been designated as the end of the estuary for the purposes of the Removal-Fill Law. For GIS users, a shape file titled 'Head of Tide Locations for Coastal Streams in Oregon' has been created from this document and may be downloaded from the [Oregon Coastal Atlas](#).

Basic information on tides is found in the [Estuary Assessment chapter of Oregon Watershed Enhancement Board's Watershed Assessment Manual](#).

If the subject waterway is not listed in the heads of tide document, a site visit should be made during a high tide when the moon is full or new ('spring tide') in the winter to determine if a water is tidal. [NOAA's website](#) has predictions of high tide times for the station closest to the waterway in question. If it is not practical to visit the waterway during a winter high spring tide, then the site should be visited during a spring tide and the timing of the observation should be interpreted in the context of the tidal cycle.

Tidal bays and estuaries are jurisdictional below the elevation of HMT or to the wetland boundary, whichever is higher, as illustrated in Figure 2-2. The HMT is defined as the "highest tide projected from actual observations within an estuary or tidal bay."

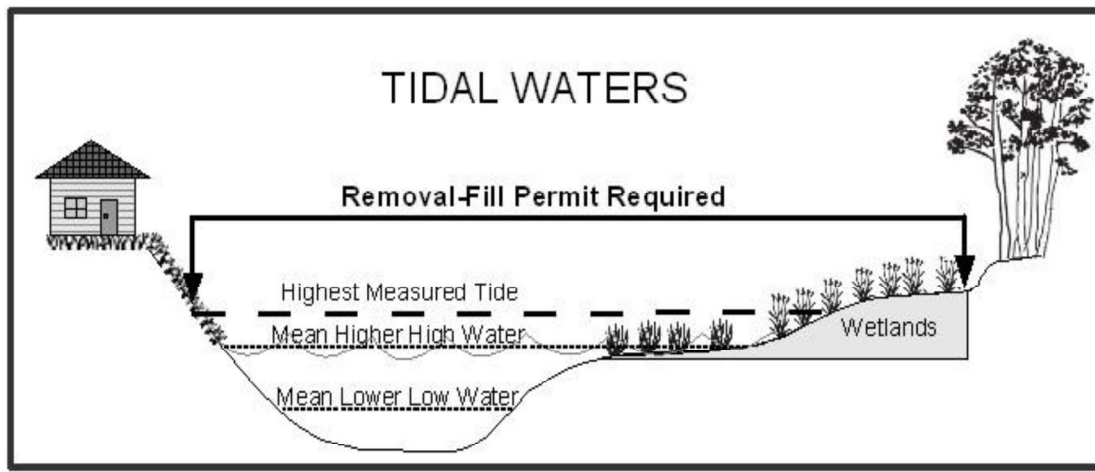


Figure 2-2: Jurisdictional boundary in waters subject to the tide.

The HMT elevation on a parcel may be determined by a land survey referenced to the closest tidal benchmark based on the most recent tidal epoch and reference to both the tidal datum (MLLW) and the fixed geodetic datum (NAVD88). In lieu of surveyed elevations, subject to approval by DSL, HMT elevation may be based upon actual tide gauge measurements during a wintertime spring tide or observation of the highest of the field indicators. These methods are outlined below.

Using Tidal Station Data: Tidal elevation data is on the NOAA's [National Ocean Service](#) website. The closest station to the subject property should be used to derive the elevation of the highest water level recorded. Because this water level is usually referenced to the station datum, it will need to be converted to the geodetic datum NAVD88. Once the highest water level elevation is identified and converted to geodetic datum NAVD88, it can be used to identify the HMT on the property through a topographic survey. A more complete description of how to use tidal data to determine Highest Measured Tide, plus a compilation of HMT Data from various stations, is available from DSL.

More information on tidal and geodetic datums is available on [NOAA's Web site](#).

Installing Tidal Gages On-Site: Installing a tidal gage on the property for a winter tide cycle is a more accurate way to determine HMT. Caution should be exercised in applying this option because data collected during the winter tide cycle may not be

representative of a typical tide cycle. Applicants seeking to pursue this option should consult with DSL before installation.

Using Field Indicators: At the discretion of DSL, field indicators may be used to determine HMT. The highest of the following field indicators can be used to determine the elevation of HMT. Examples of field indicators include:

- The uppermost drift or wrack (or debris) line containing small driftwood, mats of filamentous algae (algae that form long visible chains, threads, or filaments that intertwine forming a mat), seaweeds, sea grasses, pieces of bulrush or other emergent vascular plants, Styrofoam or other buoyant plastic debris, bivalve shells, crab molts, or other aquatic invertebrate remains
- The uppermost water mark line on an eroding bank
- The uppermost water mark line (e.g., discoloration; sediment, barnacles, snails, or algae growth) visible on a hard shoreline or bank consisting of bedrock, boulders, cobbles, riprap or a seawall
- The uppermost intertidal zone inhabited by a community of barnacles, limpets, and littorine snails along shorelines composed of bedrock, riprap, boulders and/or cobble
- The uppermost tidal marsh/upland boundary, as indicated by a dominant plant community characteristic of saltwater, brackish, or freshwater tidal plant communities changing to a dominant plant community typical of uplands
- The intertidal/upland boundary along sandy shores as indicated by the appearance of a distinct dune plant community

These field indicators are often not observable in the upper riverine portion of an estuary, in which case a topographic survey is required.

Areas behind dikes and tide gates may require additional evaluation to determine if there are jurisdictional waters and the type of water (tidal or non-tidal). If the subject area is separated from tidal influence by a properly functioning dike or a tide gate, the area behind the dike should be assessed for wetlands. Also, channels present on the site may be jurisdictional either to OHW or HMT (if tidal). If there is no tidal influence upstream of a tide gate and the area behind the dike does not meet wetland criteria, channels below OHW may be the only regulated feature.

Non-tidal Rivers, Intermittent and Perennial Streams, Lakes, and Ponds

Rivers and perennial streams have continuous flow in parts of their bed all year long during years of normal precipitation. Intermittent streams flow a portion of every year (see more details below). Lakes and ponds are bodies of standing water in depressions of land or within expanded portions of streams. Rivers, perennial and intermittent streams, lakes, ponds and jurisdictional ditches are jurisdictional to the OHW line, meaning the line on the bank or shore to which the high water ordinarily rises. The OHW line excludes exceptionally high water levels caused by large flood events (e.g., 100 year events).

Three methods are used to identify OHW: using field indicators, determining bankfull stage using local gage data, and directly observing an annual high water event. These methods can be used individually or in combination. The choice should be based on best professional judgment. However, often the most practical approach is to first look for field indicators, because local gage data is not always available and direct observation is often difficult to schedule.

Bankfull Stage is defined as the two-year recurrence interval flood elevation

Field indicators of OHW include:

- Clear, natural line impressed on the shore, including scour, shelving and exposed roots
- Change in plant community from riparian (e.g., willows) to upland (e.g., oak, fir) dominated. If the area is cropped, hydrophytic plants, or evidence of crop stress or damage from high flows would be indicative of high water.
- Textural change of depositional sediment or changes in the character of the soil (e.g. from sand, sand and cobble, cobble and gravel to upland soils). Sediments may appear stratified. This indicator may require careful evaluation on floodplains where certain farming practices regularly disturb the soil profile.
- Elevation below which no fine debris (needles, leaves, cones, seeds, soil organic matter) occurs
- Presence of water-borne litter and debris, wrack accumulation, water-stained leaves, water lines on tree trunks, flattened vegetation. Certain farming practices can obscure these indicators.

Documentation of field indicators should include a map that clearly shows the location and extent of the river, stream, lake, pond, or jurisdictional ditch; and a brief written report with ground level color photographs describing and showing the indicator(s) observed.

Determining bankfull stage: The following documents provide examples of how hydrologic data can be used to estimate OHW:

- [A Field Guide to the Identification of the Ordinary High Water Mark in the Arid West Region of the Western United States](#)
- [Determining the Ordinary High Water Mark on Streams in Washington State](#)

Documentation of bankfull determinations should include a map that clearly shows the location and extent of the stream, lake or pond; and a brief written report providing the gage data and describing the analysis method used to make the determination.

Direct observation of a high water event during a year of normal precipitation may also be used to determine OHW. The date chosen for the observation should be based on local knowledge or by estimating the likelihood of an event occurring using hydrologic data.

Documentation of annual high water events should include a map that clearly shows the location and extent of the stream, lake, pond, or jurisdictional ditch on the day of the

observation; and a brief written report that includes precipitation data and ground level color photographs to support the line drawn.

Sources of additional evidence to support OHW determinations include:

- Aerial photographs of the site (current and historic) from late winter and early spring are useful for identifying annual high water events. False-color infrared aerial photography will help differentiate between contrasting patterns of vegetation associated with active floodplains and drier terraces, and stereo pairs of aerial photographs show site topography.
- Light Detection and Ranging (LiDAR) or Shaded Relief Digital Elevation Model (DEM) data often show topographic features associated with OHW.
- County soil survey maps (including accompanying soil descriptions) and FEMA floodplain maps can help identify active floodplains.

Intermittent Streams

An intermittent stream is defined in statute as “any stream that flows during a portion of every year and which provides spawning, rearing, or food-producing areas for food and game fish” (ORS 196.800). In other words, an intermittent stream is a stream which flows during a portion of every year and which provides one or more of the following:

- Spawning areas for at least one species of food fish and one species of game fish
- Rearing areas for at least one species of food fish and one species of game fish
- Food-producing areas for at least one species of food fish and one species of game fish

Intermittent streams are jurisdictional to the elevation of OHW. A DSL jurisdictional determination applies only to the portion of the stream where the removal-fill activity is proposed or has occurred.

In contrast, ephemeral streams flow only during storm events. Streams typically begin as ephemeral, transition to intermittent, and then become perennial. However, some streams, particularly on the east side of Oregon, may flow into closed basins, may become ephemeral downstream or may even disappear.

Generally, if an intermittent stream is identified on the [National Hydrography Dataset](#) or USGS quad map, it is an indication that the stream is at least intermittent. However, if jurisdiction is otherwise unclear or disputed, additional information may be necessary to determine whether a stream is intermittent.

- Visual observations or hydrology data during years of normal precipitation may indicate that the stream flows during a portion of every year.
- Consultation with ODFW or [StreamNet](#) may confirm whether the stream segment contains spawning or rearing areas for food fish and game fish. (Note: StreamNet may not always reflect the most accurate mapping of waterways containing spawning or rearing areas for food fish and game fish.)

- If confirmation of spawning or rearing areas for food and game fish is not possible, then determining whether the stream segment is a food producing area will be necessary. Generally this occurs when the flow is of sufficient duration to support amphibians and aquatic insects, and provide other food web support mechanisms, such as conveyance of particulate organic matter. The Streamflow Duration Assessment Method (SDAM) may be applied to see if the stream segment has sufficient flow to provide food or food web support. SDAM is not required to make stream flow duration determinations. The method was designed to be an assessment tool and should support, not replace best professional judgment. To be intermittent at least one food fish and one game fish must be present downstream or the stream must be a tributary to a stream with the fish present. Consultation with ODFW or [StreamNet](#) may be required to determine this fish presence.

Wetlands

Wetlands are areas that are inundated or saturated by surface or ground water at a frequency and duration sufficient to support, and under normal circumstances do support, a prevalence of vegetation typically adapted for life in saturated soil conditions. Wetlands are jurisdictional within the wetland boundary.

A wetland boundary is delineated and mapped according to the [wetland delineation manual](#) developed by the Corps. Wetland delineation reports are prepared by wetland consultants and submitted to DSL for review and approval (jurisdictional determination). Jurisdictional determinations for wetlands are valid for a period of five years, unless new information necessitates a revision. In comment below:

Jurisdiction over compensatory mitigation sites: Mitigation sites that are referenced in a removal-fill authorization are jurisdictional for the entire area of the mitigation site, as shown in the authorization, including any upland buffers. Any amount of removal or fill within mitigation sites requires a permit. To determine whether there is a compensatory mitigation site at a project location, contact DSL.

Reservoirs

A reservoir is a natural or artificial pond or lake used for storing and regulating water. Reservoirs are jurisdictional to the normal operating pool level (sometimes called the full-pool elevation), or to the upper edge of an adjacent wetland, whichever is higher.

In most cases, the normal operating pool level of a reservoir coincides with a very clear line on the bank around the reservoir where the vegetation, slope and soil characteristics change dramatically. Indicators of this line are similar to the OHW line indicators for streams and rivers. For larger reservoirs, the applicant may want to verify the elevation of this line with elevation data from the entity that manages the reservoir (the Corps, an electric company, or a local irrigation or water management district).

Artificially Created Ponds and Wetlands

Artificially created ponds and wetlands are waters that exist as a result of some human activity. They are jurisdictional if they meet any one of the following criteria (other than the exceptions listed below):

- Greater than or equal to one acre in size (unless created for one of the purposes listed below)
- Created, in part or in whole, in waters of this state
- Identified in an authorization as a mitigation site

Exceptions: The one-acre size threshold does not apply to wetlands or ponds artificially constructed entirely from uplands for the purpose of:

- Wastewater treatment
- Settling of sediment
- Stormwater detention or treatment
- Agricultural crop irrigation or stock watering
- Fire suppression
- Cooling water
- Surface mining
- Log storage
- Aesthetic purposes

Legally constructed ponds that are artificially created and are severed from interaction with the surrounding environment by an impermeable liner are not jurisdictional.

To determine whether a wetland or pond was “created in part or in whole in a water of this state”, the applicant should use the following resources to research the historical site conditions. Generally, if any of the following situations exist in any portion of the created wetland or pond, it was likely created in part or wholly in a water of this state:

- The USGS map shows a channel flowing through, into or out of the artificially created pond or wetland
- Historical aerial photos show a water body, inundation or an area devoid of vegetation in early spring
- NWI or LWI maps show a wetland identified at the site
- Hydric soils maps from the County Soil Survey show that the site is mapped as a hydric soil unit, or is in a low topographic position in a soil unit with hydric soil inclusions
- There are springs, seeps or wetlands upslope of the site, or a channel flowing into the site

When an existing **jurisdictional pond, wetland, or waterway** is enlarged through artificial means, such as redirection of water or excavation, the additional area is included in the jurisdictional boundary.

Following are some examples of jurisdictional artificially created ponds and wetlands:

- A flood-irrigated pasture that meets wetland criteria, greater than one acre, where no wetland or waterway existed on the site prior to flooding
- A wetland caused by water backing up behind an undersized culvert in an intermittent stream

- A two-acre wildlife pond created by construction of a berm or excavation of material in a non-jurisdictional drainage

Figure 2-3 provides a step-by-step procedure for how to determine if an artificially created wetland or pond is jurisdictional.

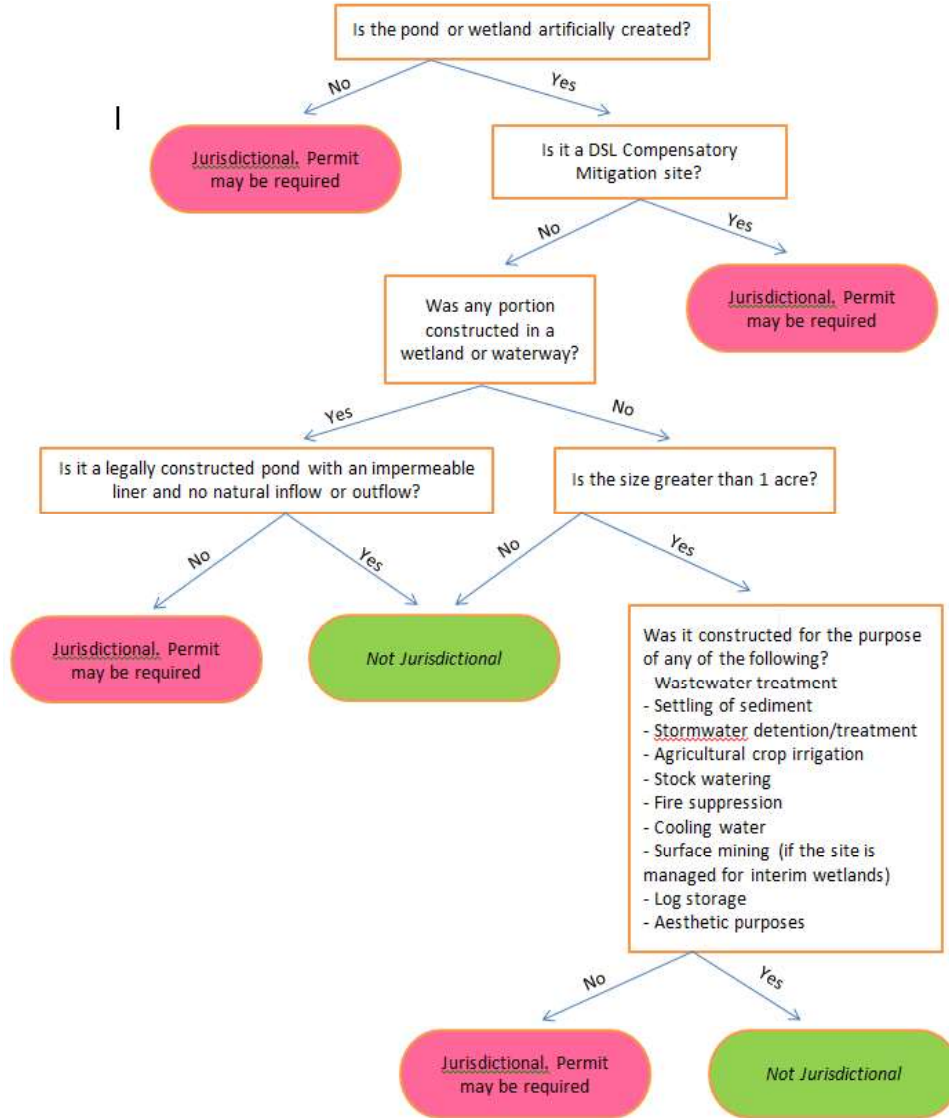


Figure 2-3: Jurisdiction flowchart for artificially created ponds and wetlands.

Ditches

A ditch is a manmade water conveyance channel. Channelized or straightened natural waterways are not considered ditches. If the channelized waterway is shown as an intermittent or perennial stream on a USGS map, it is likely not a ditch, but a channelized stream. Likewise, if historical aerials show the waterway in a different location, it is likely a channelized stream.

Ditches created in wetlands are jurisdictional (with the exception of some irrigation ditches and roadside and railroad ditches as described below).

Ditches created in uplands are jurisdictional if they meet both of the following:

- Have a free and open connection to a waterway: A “free and open connection” means a connection by any means, including but not limited to culverts, to or between natural waters that allows the interchange of surface flow at bankfull stage (the two-year recurrence interval flood elevation) or OHW, or at or below HMT between tidal waterways.
- Contain food *and* game fish: Because the list of food fish includes almost any fish (there is no list available), and the ditch must have both to be jurisdictional, the game fish list (ORS 496.009) is used to establish jurisdiction. Ditches created from upland that have fish screens are generally not jurisdictional.

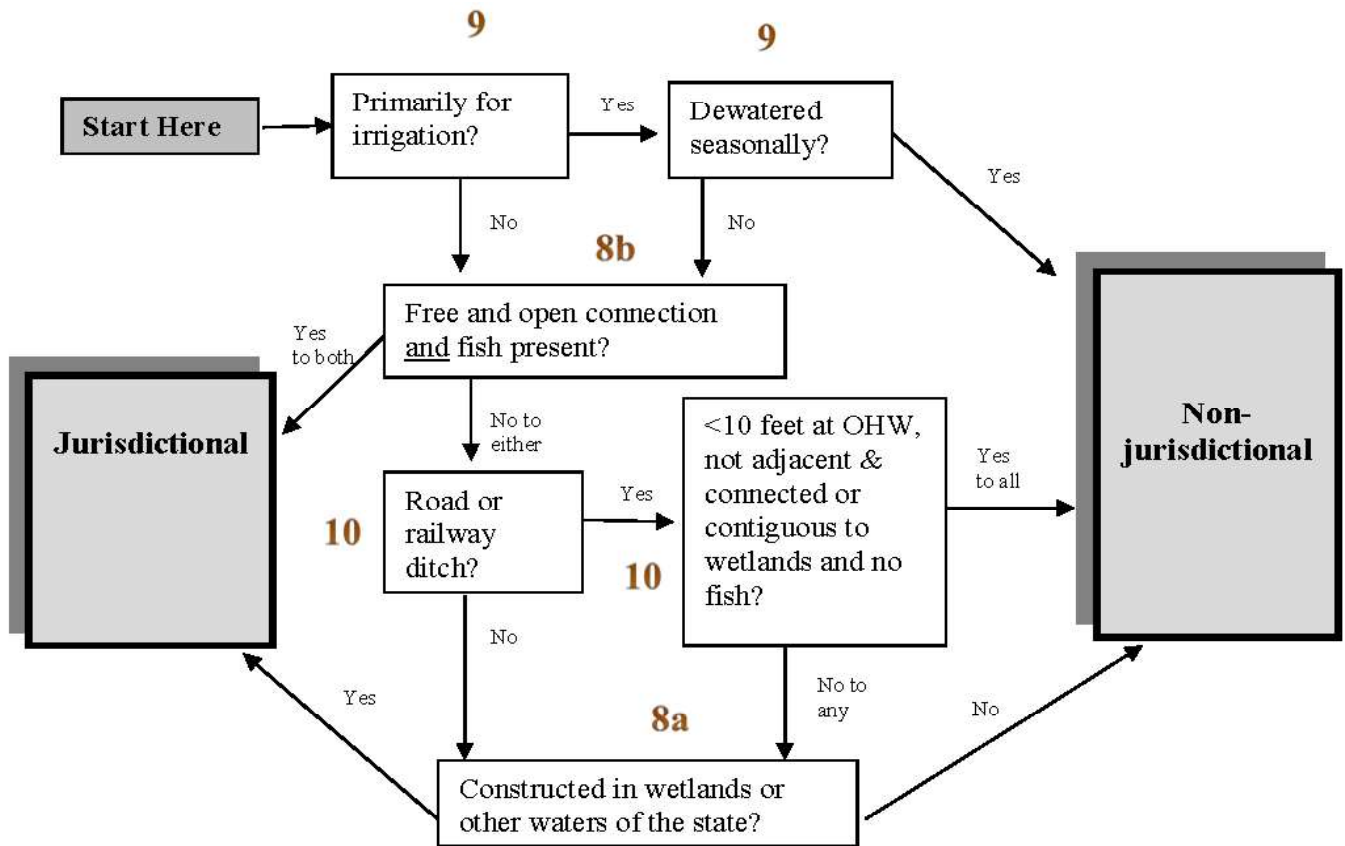


Figure 2-4: Jurisdiction flowchart for ditches.

Irrigation Ditches

Regardless of whether it was created in wetlands or uplands, an irrigation ditch is not jurisdictional if it meets both of the following:

- The ditch is operated and maintained for the primary purpose of irrigation.

- The ditch is dewatered for the non-irrigation season except for isolated puddles in low areas. “Dewatered” means that the source of the irrigation water is turned off or diverted from the irrigation ditch. A ditch that is dewatered during the non-irrigation season may be used for temporary flows associated with stormwater collection, stock water runs, or fire suppression.

Roadside and Railroad Ditches

Regardless of whether it was created in wetlands or uplands, a roadside or railroad ditch is not jurisdictional if it meets all of the following:

- It is ten feet wide (average) or less at OHW or the wetland boundary
- It is not adjacent and connected or contiguous to wetlands. (If so, only the portion that is connected or contiguous with the wetland is jurisdictional.)
- It does not contain fish

Note that a roadside ditch is always jurisdictional if it is a channelized stream, or if it has a free and open connection to another water and contains food and game fish.

Figure 2-5 illustrates a portion of a roadside ditch that is jurisdictional because it is adjacent to a wetland. (A ditch may be considered adjacent to a wetland even if there is an upland berm between the ditch and the wetland.)

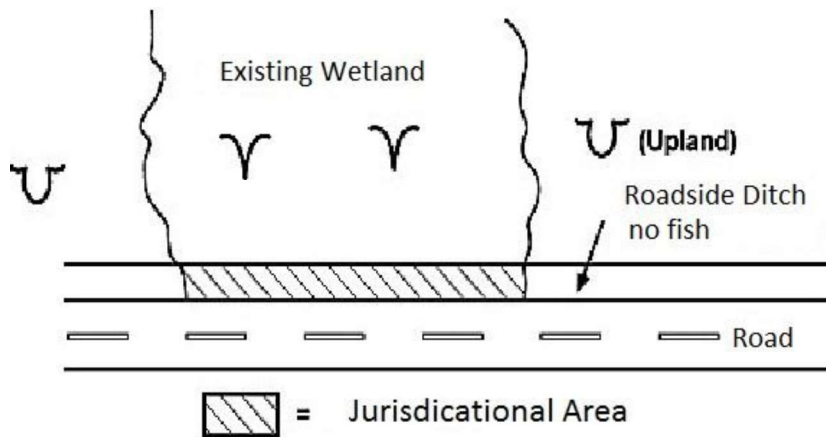


Figure 2-5: Jurisdiction of a roadside ditch with adjacent wetlands.

If an applicant is uncertain about whether a ditch is jurisdictional, he or she should contact a Jurisdictional Coordinator or Aquatic Resource Coordinator. Figure 2-4 may also help to determine whether a ditch is jurisdictional.

Definition of Removal and Fill

As stated in statute and rule:

"Removal means the taking of more than 50 cubic yards of material (or its equivalent weight in tons) in any waters of this state in any calendar year; or the movement by artificial means of an equivalent amount of material on or within the bed of such waters, including channel relocation. However, in designated Essential Salmonid Habitat areas and State Scenic Waterways, the 50-cubic-yard minimum threshold does not apply."

In other words, removal involves:

- More than 50 cubic yards (except in State Scenic Waterways, ESH streams, or mitigation sites where the threshold is zero)
- Inorganic material and Large Woody Debris
- Either taking material from the bed and/or banks or "movement" of material within the bed and banks

"Channel relocation" means to change the location of a channel. If more than 50 cubic yards of material is removed in moving the channel or if it would require more than 50 cubic yards of material to completely fill the old channel, a permit is required.

Movement may include disturbance of the substrate or other inorganic materials associated with embedded organic materials such as salvage logs, wood piling, log jams and beaver dams. While, other than Large Woody Debris, removal of the organic material is not regulated, disturbance of the associated inorganic material may be considered movement.

Examples of removal are: digging a ditch through a wetland, excavating a foundation in a wetland, or dredging to remove sediment from a waterway. Examples of movement are plowing in a wetland or moving gravel around in a stream.

"By artificial means" is the *purposeful* movement or placement of material by humans and/or their machines.

Definition of Fill

As stated in statute and rule:

"Fill means the total of deposits by artificial means equal to or exceeding 50 cubic yards or more of material at one location in any waters of this state. However, in designated ESH areas and in State Scenic Waterways, fill means any deposit by artificial means."

In other words, fill involves:

- Equal to or greater than 50 cubic yards, except in State Scenic Waterways, ESH areas, mitigation sites, or if the project is for an Ocean Renewable Energy Facility where the threshold is zero
- Inorganic or organic material
- A one-time volume with no annual allotment
- Includes the entire project location(s)

The rules define “**location**” as the entire area where the project is located. In determining whether the cubic yard threshold is met, all the removal-fill activities in all waters of this state for the entire project must be included to determine whether a permit is needed.

Examples of fill are placing material for a road or building pad in a wetland, placing rip-rap on a stream bank, placing large wood into a stream or pushing material into a stream. Note that fill does not require that the material be imported from another site. Fill can include moving or pushing material from an upland location on a site into a water or wetland.

Removal-Fill Volume Thresholds

Once it has been determined that a proposed removal-fill activity is located in a jurisdictional water of the state, then it must be determined if the activity exceeds the applicable volume threshold, which is the amount of removal or fill allowed without a permit.

Volume Threshold for Many Waters

For many waters of this state, 50 cubic yards or more of *fill* requires a permit. More than 50 cubic yards of *removal* within waters of this state in any calendar year requires a permit. For projects with both removal and fill, the cubic yards of removal is added to the cubic yards of fill. A permit is required if the combined total exceeds 50 cubic yards.

Volume Threshold for State Scenic Waterways

Any amount of removal or fill activities in State Scenic Waterway requires a permit, except for certain prospecting. A permit is not required for:

- Prospecting that involves:
 - Less than one cubic yard of removal-fill at any one individual site in any year
 - Less than 5 cubic yards of removal-fill, cumulatively, in any single waterway in any year

Volume Threshold for Essential Salmonid Habitat

Any amount of removal-fill in ESH waters requires a permit, except higher thresholds are allowed for certain activities (See [Chapter 3: What Activities Are Exempt?](#)):

- prospecting and other non-motorized activities involving less than one cubic yard of removal-fill at any one site and cumulatively less than 5 cubic yards of removal-fill in any single waterway in any year
- fish passage and fish screening structures may be constructed, operated, or maintained up to 50 cubic yards without a permit under ORS 498.306, 498.316, 498.326 or 509.600 to 509.645
- activities customarily associated with agriculture involving 50 cubic yards or less

Though shown on the maps as a line, ESH waters are jurisdictional to Ordinary High Water or Highest Measured Tide, even if muted behind tidegates. Adjacent wetlands may also be ESH. Tributaries not mapped as such are not ESH upstream of the OHW or HMT elevation of the ESH waterbody.

Volume Threshold for Compensatory Mitigation Sites

Compensatory mitigation sites are areas that have been created, restored or enhanced as part of a project and are referenced in an authorization issued by DSL. At compensatory mitigation sites, any amount of removal or fill requires a permit. The zero volume threshold for compensatory mitigation sites applies to the entire area of the site, including any upland buffer areas.

Volume Threshold for Ocean Renewable Energy Facilities

The threshold volume for removal-fill in Oregon's territorial sea that is related to an ocean renewable energy facility is any amount greater than zero.

Essential Salmonid Habitat (ESH) Defined:

ESH is the habitat necessary to prevent the depletion of native anadromous salmon species (chum, sockeye, Chinook and Coho salmon, and steelhead and cutthroat trout) during their life history stages of spawning and rearing. The designation applies only to those species that have been listed as Sensitive, Threatened or Endangered by a state or federal authority. DSL, in consultation with ODFW, designates ESH based on field surveys and the professional judgment of ODFW's district biologists.

ESH-designated areas include the stream segment identified on the ESH map and any adjacent off-channel rearing or high-flow refugia habitat with a permanent or seasonal surface water connection to the stream.

Adjacent off-channel rearing or high refugia habitat includes wetlands connected by shallow surface water during high water or flood events. For tidal streams and estuaries, it would include the wetland area inundated by higher high tides. For non-tidal areas, the wetland area within the 100-year floodplain could be ESH, (unless excluded from flooding by a dike or other obstruction). If a wetland is within the 100-year floodplain, the site should be investigated for physical indicators of inundation, such as debris lines or drainage patterns. Floodplain maps and knowledge from landowners about the frequency of inundation may also be helpful. Note that only the wetland area within the inundation area would be considered ESH wetland and subject to the zero cubic yard threshold. Portions of the wetland that are not connected by surface water would be subject to the 50 cubic yard threshold.

Calculating Removal-Fill Volumes

What to Include in the Volume Calculation

In determining whether a permit is required for a project, the volumes of material that are placed, excavated or moved within a jurisdictional area, whether temporary or permanent, for the entire project are added together. If the volume thresholds are met, a permit is required.

For example, if a project involved temporary excavation of 25 cubic yards in a stream or wetland and the same 25 cubic yards are returned in the same location, a permit would be required.

In a non-wetland waterway, fill and removal volumes include the amount below OHW or HMT (in tidal areas). Excavation volumes include the amount below the OHW down to the full extent of the excavation.

In a wetland, fill is measured to the height of the fill (excluding buildings and other structures) and removal includes all excavation within the wetland boundary.

“Project” defined: For the purpose of determining if the volume threshold is met, a “project” is defined as the primary development or use intended to be accomplished. A project is conducted at one “location” which is defined as the entire area where the project is located. A “project” must have independent utility and may involve more than one removal-fill site.

Special note regarding directional boring: If a directional bore enters the ground in uplands, goes under the creek bed or wetland, and exits in uplands, the activity does not require a permit. If a “frac-out” occurs as a result of the boring activity, the discharge and removal of the drilling mud may be considered removal or fill subject to the volume thresholds. The Department would typically handle this situation as an emergency authorization.

Examples of Removal-Fill Volume Calculations

Excavation on the Bank of a Stream

When excavating on a bank of stream, all removal below OHW must be included in the calculation. In Figure 2-6, only area 1 is considered in the calculation of removal volume.

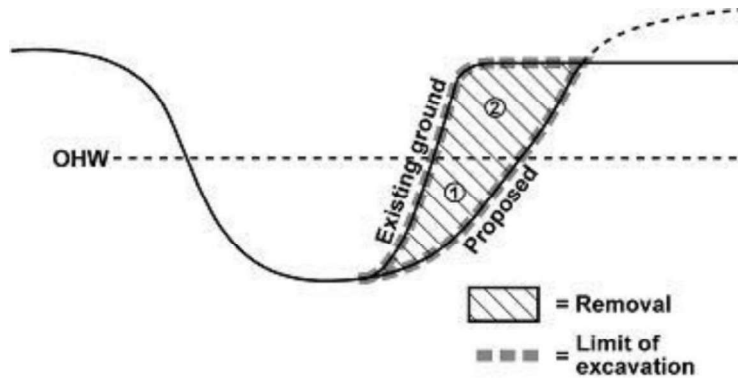


Figure 2-6: Only area 1 is included in the calculation of removal volume.

Calculating Volume for Excavation at the Wetland/Upland Boundary

When excavating at a wetland/upland boundary, as shown in Figure 2-7, the area excavated in upland is not included in the calculation.

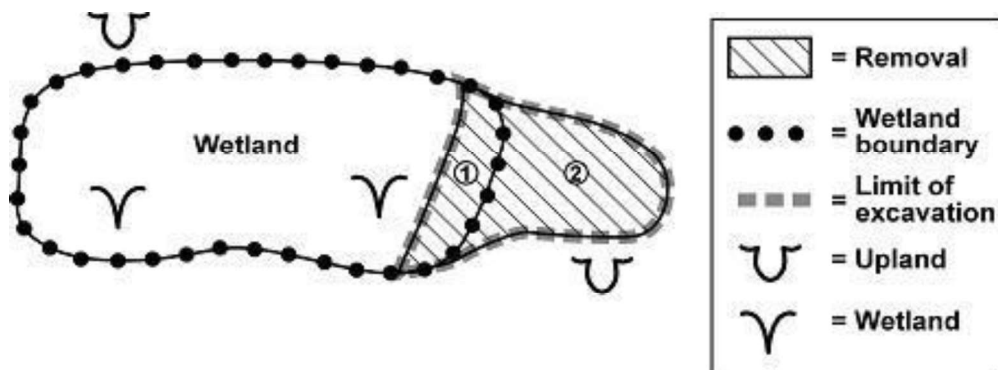


Figure 2-7: Only area 1 is included in the calculation of removal/fill volume at the wetland/upland boundary.

Calculating Volume for Trenching

For trenching and other temporary impact activities where material is first removed and then placed back in the trench, the volume calculation includes both removal and fill within the jurisdictional area only. As shown in Figure 2-8, the material in area 1 would be calculated twice (once as removal and once as fill).

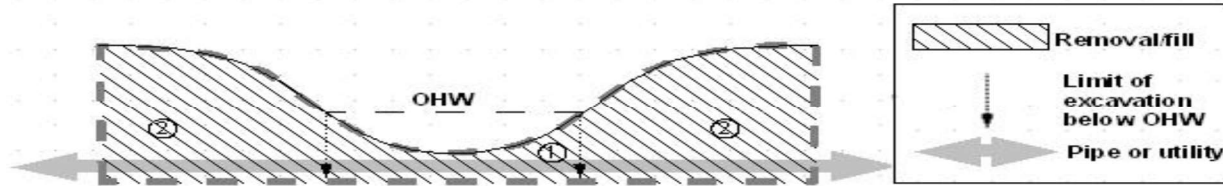


Figure 2-8: Only area 1 is included in the calculation of volume, but it is included as both removal and fill.

Calculating Volume for Channel Relocation

To calculate the removal-fill volume for a channel relocation project, evaluate both of the following volumes:

- The volume of material that will be removed to construct the new channel
- The volume that would be needed to entirely fill the old channel to the OHW Line, even if the proposed project will not fill the channel in its entirety

If either of these two amounts is greater than 50 cubic yards, a permit is required. It is important to note that if a stream is relocated, the new channel becomes jurisdictional. The old channel may remain jurisdictional if it meets wetland criteria or meets the definition of intermittent or perennial stream.

Calculating Volume for Culvert Projects

When calculating fill and removal volumes for culvert replacement projects, the **interior of the culvert is not included**. As shown in Figure 2-9, only the volume of material in area 2 is included in the removal-fill calculations.

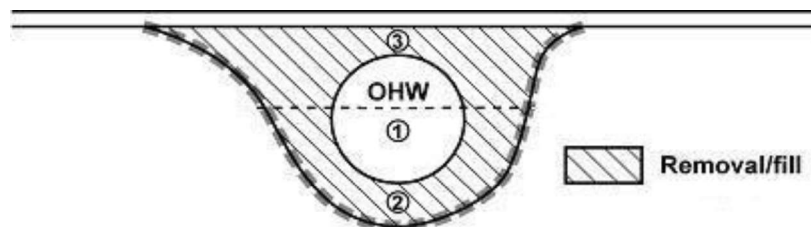


Figure 2-9: Only area 2 is included in the calculation of removal/fill volume

Temporary Removal and Fill Volumes

Removal and fill volumes associated with temporary impacts such as temporary stockpiling of materials, temporary access roads, work-area isolation structures, and spud piles must be included in the volume used to determine if a project exceeds the thresholds.

Special Situations: Activities That Cannot Be Permitted by Rule or Law

Prohibited Activities within the territorial sea and navigable bays

DSL is owner of certain lands, including most submersible and submerged lands within the territorial sea and navigable bays. As landowner, per statute and rule there are certain activities DSL may not enter into a contract to allow. DSL cannot grant permission for the following activities:

- Exploration for Minerals on State-Owned Submersible and Submerged Lands Within the Territorial Sea and Navigable Bays (ORS 274.610)
- Removal of kelp or other seaweed for commercial purposes on state owned land. (OAR 141-125-0110 (14))
- Exploration, development, or production of oil, gas, or sulfur is prohibited in the territorial sea. (2010 Note to ORS 274.710)

Because the landowner (DSL) cannot authorize use of the lands for these activities a removal fill permit cannot be issued.

Prohibited Activities in Smith or Bybee Lakes

DSL cannot issue a removal or fill permit within Smith or Bybee Lakes, other than for maintaining fish and wildlife habitat or to support recreational use or public access. Any activity for enhancing or maintaining fish and wildlife habitat must be approved by ODFW. (ORS 196.820(1) and (2))

Chapter 7: Emergency Permits – *At a Glance*

What is an Emergency?

Within the context of the Removal-Fill Law, an emergency is a circumstance that poses an immediate and direct threat to public health, safety, or substantial property. If the actions necessary to alleviate the threat involve 50 cubic yards or more of removal or fill below a waterway's ordinary high water (OHW) elevation or in wetlands, or any amount of removal or fill in designated [Essential Salmonid Habitat \(ESH\)](#), [State Scenic Waterway \(SSW\)](#), or mitigation site, a DSL permit is required and may be authorized as an expedited emergency permit (EP).

The Procedure for Obtaining an Emergency Permit

Step 1: The applicant must provide information including location, nature and cause of the threat, the condition of the waters of this state, and what action is necessary to alleviate the immediate threat. Remedial actions must be limited to the minimal amount of impacts necessary prevent irreparable harm, injury or damage to persons or property.

Step 2: Contact DSL to initiate the EP process.

During Business Hours: 503-986-5200 (west of Cascades) or 541-388-6112 (east of Cascades)

After Business Hours: Oregon Emergency Response: 1-800-452-0311

Step 3: Submit the EP application materials as directed by the DSL Aquatic Resource Coordinator and as time allows. DSL may conduct a site visit or ask another designated agency, such as ODFW, to do so.

Step 4: Qualifying activities will be issued a written permit as soon as key information is provided. DSL can issue a verbal approval in advance of the written approval where it is necessary to protect public health, safety, or property.

After the Emergency

DSL staff may visit the site upon completion of the emergency work and may require the project be modified or require mitigation to compensate for any impacts to the affected wetland or waterway. A subsequent permit may be required to conduct remedial work.

Chapter 7: Emergency Permits

What is an Emergency?

Oregon Administrative Rule defines an emergency as natural or human-caused circumstances that pose an immediate threat to public health, safety or substantial property, including cropland. DSL will use this definition and apply all the following considerations to assess whether an activity in wetlands or a waterway is eligible for an Emergency Permit (EP):

- Does the emergency pose a direct threat to public health or safety or substantial property, including but not limited to a dwelling, transportation structure, farm, or cropland?
- Does the nature of the threat allow enough time to obtain some other form of permit or is prompt action required to reduce or eliminate the threat?
- Is the proposed project the minimal amount necessary to reduce or eliminate the threat and minimizes, to the extent practicable, adverse impacts to waters of this state?

The Procedure for Obtaining an Emergency Permit

Step 1: Before Contacting DSL - the Emergency Situation Must be Documented

To support a determination an emergency exists and to facilitate approval of the emergency action, the applicant should be prepared to provide the following information during the first contact with DSL:

- The type of property at risk
- The cause of the threat
- The reason prompt action is necessary and why there is not enough time to obtain another type of permit
- The location, including township, range, section, tax lot, and latitude and longitude
- The date the damage or threat was first observed or the date of the event that precipitated the threat
- The nature of the habitat being affected (e.g., if bank erosion, the slope and soil texture of the bank, types and extent of vegetation in the vicinity)
- What action(s) are necessary to alleviate the immediate threat, including: volumes and area of removal or fill, construction methods, construction timeline and other project specific information to allow DSL to understand the proposed emergency work
- Photos of the damage and proposed treatment area

- The name and contact information of consultants or engineers working on the emergency project
- Property owner information, including permission to conduct the emergency work

Actions must be limited to what is necessary to alleviate the emergency. Because the purpose of an EP is to alleviate the emergency situation, it is important the project be the minimal amount of work to alleviate the threat and minimize adverse effects to waters of this state. Additional removal or fill activities beyond that necessary to alleviate the immediate threat are not allowed under an EP.

Some emergency actions may be exempt from a DSL permit requirement. Two exemptions are commonly applied in emergency situations:

- Emergency repair to currently serviceable roads, bridges, and other transportation-related structures
- Maintenance of certain water control structures

Exemptions are further discussed in [Chapter 3: What Activities Are Exempt?](#) It is recommended that the exempt status of a proposed action be confirmed with a DSL Aquatic Resource Coordinator before proceeding.

Step 2: Contacting DSL

Once the emergency situation has been documented, DSL should be contacted as soon as possible.

During Business Hours

Normal business hours are Monday – Friday, 8:00 a.m. to 5:00 p.m. Requests for EPs are initiated by calling the Salem office (503-986-5200) on the west side of the Cascades; and the Bend office (541-388-6112) on the east side. The Aquatic Resource Coordinator serving the appropriate county will handle the EP request.

After Business Hours

If the nature of the emergency is such that waiting until regular business hours is not possible, the [Oregon Office of Emergency Management](#) (Oregon Emergency Response System) should be contacted (1-800-452-0311). The operator will take information regarding the emergency and contact the appropriate agency for immediate follow-up.

Response from DSL upon Contact

DSL will provide the following guidance during the initial contact:

- Determine if a permit is required from DSL for the proposed action and if the action is eligible for an EP
- Discuss what other information may be needed to process the request
- Explain the process and timeframe for making a final decision
- Provide an EP application form
- Arrange for a site visit, if time allows and if necessary
- Determine if we will issue a verbal approval during the first contact

If there is sufficient time to prepare an application, the applicant will be asked to do so. If there is not sufficient time, and an emergency has been confirmed, DSL can issue a verbal authorization. If DSL issues a verbal authorization, a written authorization will be issued within five calendar days. The application should be submitted as soon as possible after the emergency work, generally the next day.

Aquatic Resource Coordinators will document the verbal authorization in the EP file, including volumes of removal or fill, design of the emergency work and construction methods authorized. To avoid enforcement action, the application must reflect what was authorized verbally.

Depending on the nature of the emergency and the scope of the proposed action, DSL staff may conduct a site visit or request local ODFW staff to visit the site to verify the emergency situation, evaluate the appropriateness of the proposed action, and develop site-specific EP conditions that may be warranted.

Contacting Other Agencies

DSL will typically contact the local ODFW office to get input on the emergency situation and what changes may be incorporated into the proposed action to limit impacts to waters of this state. Applicants may contact the [ODFW field office](#) directly to get input on the proposed action.

The emergency work may require approval from the Corps. The Corps may be contacted at 503-808-4373 (Portland office) or 541-465-6877 (Eugene office).

Step 3: Submitting the EP Application

Submittal Requirements

The emergency application form is available on the DSL Website and by e-mail or fax upon request. The emergency application must be filled out completely and sent back to the appropriate DSL office by mail or electronically. The information required by DSL on the application includes:

- Applicant name, address phone number, fax and e-mail
- Entity responsible for performing the activities
- Landowner permission (if different from the applicant)
- Project location (Township, range, section, tax lot, and latitude and longitude) and driving directions
- Date the threat (for example, erosion or landslide) occurred
- The need for the project including an explanation the nature of the direct threat to public health, public safety, or property
- Specific description of the proposed project (dimensions, amount of material to be removed and/or filled in wetlands or waterway)
- A determination if the project is a permanent or temporary solution
- Construction schedule

- Construction plan (how the work will be accomplished, equipment used, site access, etc.)
- Drawings including a location map, plan view, and cross section view
- Photos

Timelines for Processing the Emergency Application

State law and administrative rules do not establish a timeline by which DSL has to make a decision for an EP. DSL understands time is of the essence when an emergency exists and will act as promptly as possible to provide a timely decision.

Application Fees

The EP may be subject to an application fee according to the fee schedule. If a fee is applicable, the amount will be identified and payment required in the EP. Payment is required within 45 days of the EP issuance date.

Step 4: Receiving Approval

Verbal and Written Approvals

If the nature of the emergency is such that an immediate approval is necessary to protect public health, safety or substantial property, DSL may issue a verbal approval as soon as sufficient information is provided to make an informed decision. At the time a verbal approval is provided, the Aquatic Resource Coordinator will explain the location and volumes of removal or fill being authorized and any special conditions required to protect the aquatic environment.

If a verbal approval is given, it will be followed up with a written approval within five days. A written approval will include:

- The party authorized and responsible for the work
- The location and types and volumes of material authorized for removal-fill
- Best management practices to minimize effects on the waterway
- Other permit conditions specific to the site
- ODFW pre-action notification requirement
- Any post project reporting requirements
- Expiration date
- Permit conditions for follow-up work

If DSL determines that the situation or the proposed action does not qualify for an EP, the applicant will be informed of the reason(s) why. The applicant may apply for approval through DSL's standard permitting options.

Conditions of Approval

The person identified on the EP is responsible for complying with the permit conditions, including, but not limited to:

- Use of certain erosion control methods
- Planting requirements
- Post-project reporting
- Mitigation for adverse impacts
- Project modifications post construction
- Requirement to apply for a removal-fill permit once the emergency situation has subsided
- Other BMPs and conservation measures necessary to protect the aquatic environment

A site visit does not eliminate the permittee's responsibility to provide a post-construction report stipulated in the EP.

Expiration of the Emergency Permit

The term of the EP will be limited to the time necessary to reasonably complete the proposed action. EPs are typically valid for no more than 60 days. The expiration date will be clearly identified in the written permit. If the work cannot be completed by the expiration date, a new permit must be obtained.

After the Emergency

Because the review of emergency application is expedited and there is usually not the opportunity for agency input, certain follow-up actions are usually required.

Site Visit

DSL staff may visit the project site upon completion of the emergency work. The purpose of such a visit will be to determine if:

1. The project was conducted as authorized in the EP
2. Any project modifications are needed to minimize effects to the wetland or waterway
3. There are permanent effects that require mitigation
4. If further site monitoring is required

Additional Work May Be Required

DSL may require the project be modified after the initial emergency work is completed. If the emergency work is determined to be non-sustainable or to present an unacceptable level of impact to the aquatic environment, a modification of the emergency work may be required. For example, if rip-rap is allowed under an EP, the applicant may have to remove the rip-rap, slope the river bank and plant woody

vegetation as a more permanent solution to the erosion problem with less adverse effects. This work may require a separate authorization and would need to be done in the next in-water work period.

If impacts incurred from an emergency action are allowed to remain, the applicant may be required to provide compensatory mitigation. Mitigation actions may include purchase of credits from a mitigation bank, planting riparian vegetation, or other actions necessary to offset the adverse effects of the emergency work. Depending on the nature of the required mitigation, a separate DSL approval may be required.

Compensatory Mitigation at a Glance

[Compensatory Mitigation Planning for Wetlands, Streams, Tidal and Non-tidal Waters, and Aquatic Resources of Special Concern](#)

When applying for a permit to impact waters of this state, the applicant is required to “mitigate” these impacts. Mitigation is a process to reduce the effects of the proposed project and includes avoidance and minimization. This chapter assumes that all possible steps have been taken to avoid and minimize the impacts and the applicant now needs to replace or “compensate” for the ecological characteristics (functions) and societal benefits (values) that will be permanently lost.

“Tidal Waters,” as defined by rule, includes the area between highest measured tide and extreme low tide, or to the elevation of any eelgrass beds, whichever is lower.

The success of a mitigation project depends upon multiple factors including appropriate siting, a sound project design and monitoring plan, and the site’s ability to be self-maintaining. Compensatory mitigation will normally require the assistance of trained professionals to assure that projects are successful and that plans and reports contain sufficient detail to satisfy Department of State Lands (DSL) requirements.

There are three general steps in compensatory mitigation planning:

- [Step 1:](#) Evaluate project impacts (direct and indirect) on acreage/linear feet, and functions and values
- [Step 2:](#) Select the mitigation opportunity(ies) that will best offset those impacts
- [Step 3:](#) Develop the mitigation plan as part of a permit application to DSL

This guidance is applicable to all compensatory mitigation (CM). CM is mitigation for impacts to wetlands, rivers, streams, tidal and non-tidal waters, and other jurisdictional waters of this state. Applicants will follow a two part process for proposing CM project. They will first demonstrate that a proposed mitigation site is eligible to offset the proposed impacts and then they will quantify mitigation requirements. Eligibility requirements for mitigation projects are consistent for all waters of this state. Mitigation accounting policy for wetlands has been developed utilizing function and value assessments and an accounting worksheet to quantify mitigation requirements in acres. Mitigation accounting policy for non-wetland mitigation is still being developed. Applicants proposing impacts to waters of this state should work closely with a DSL Aquatic Resource Coordinator to assure compliance with the mitigation eligibility and accounting requirements.